

6. Block diagrams

Block diagram (Part 1)

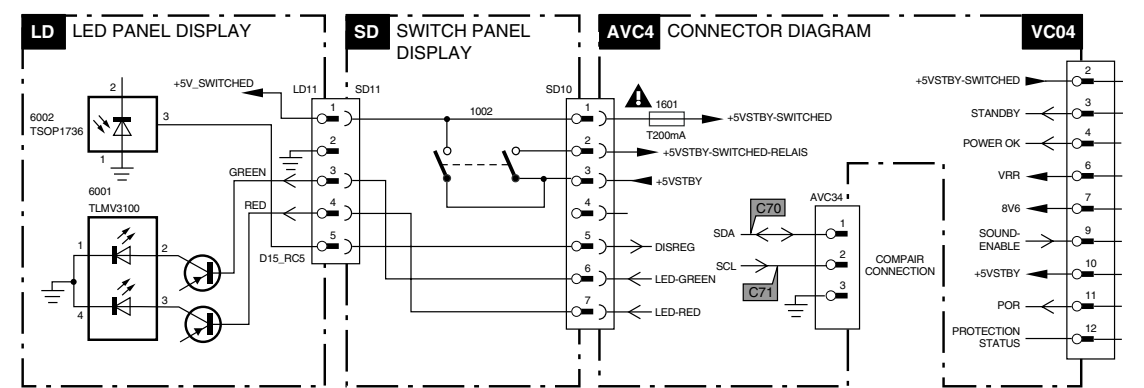

Block diagram (Part 2)

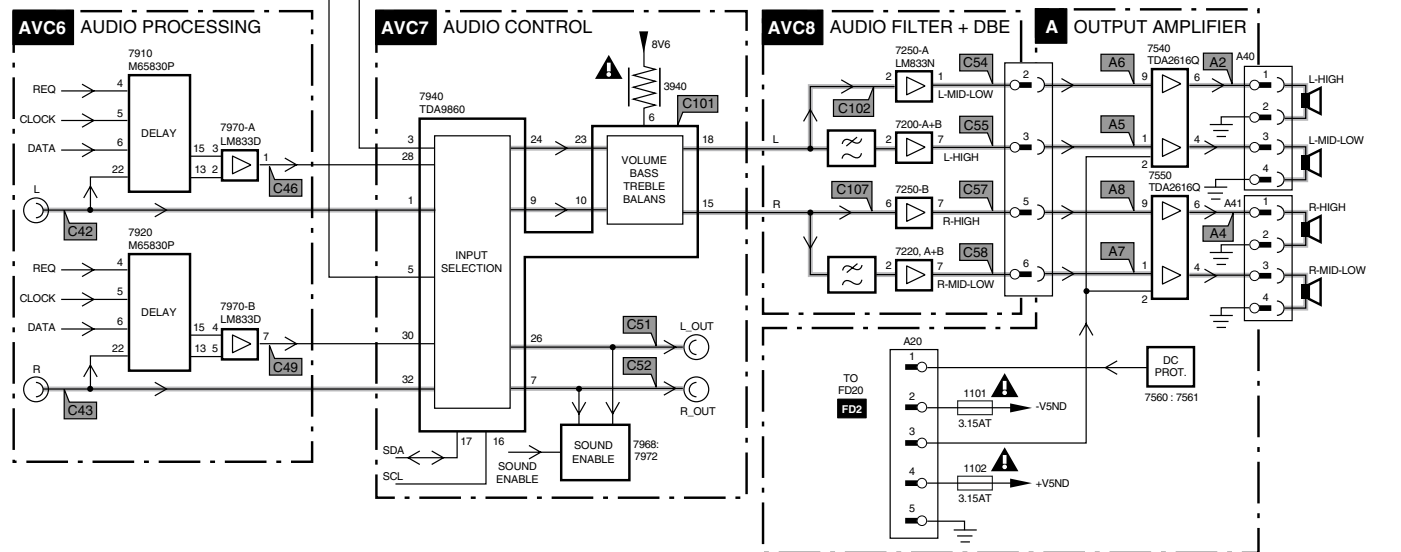
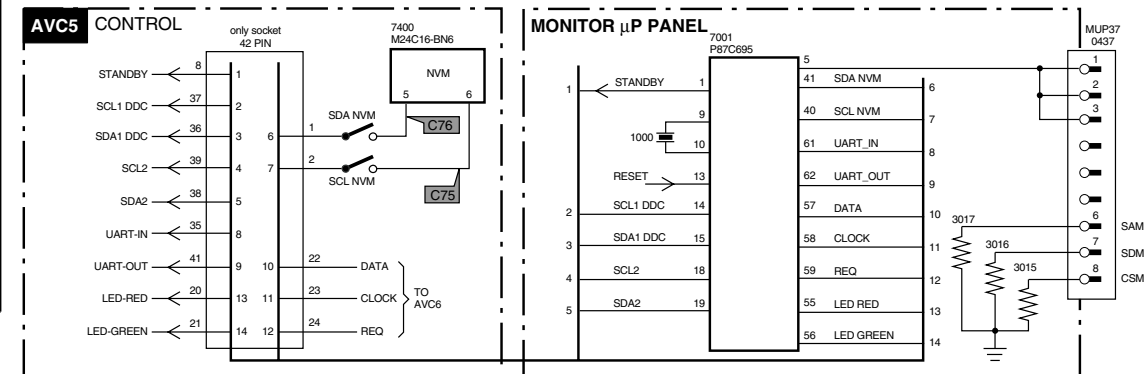
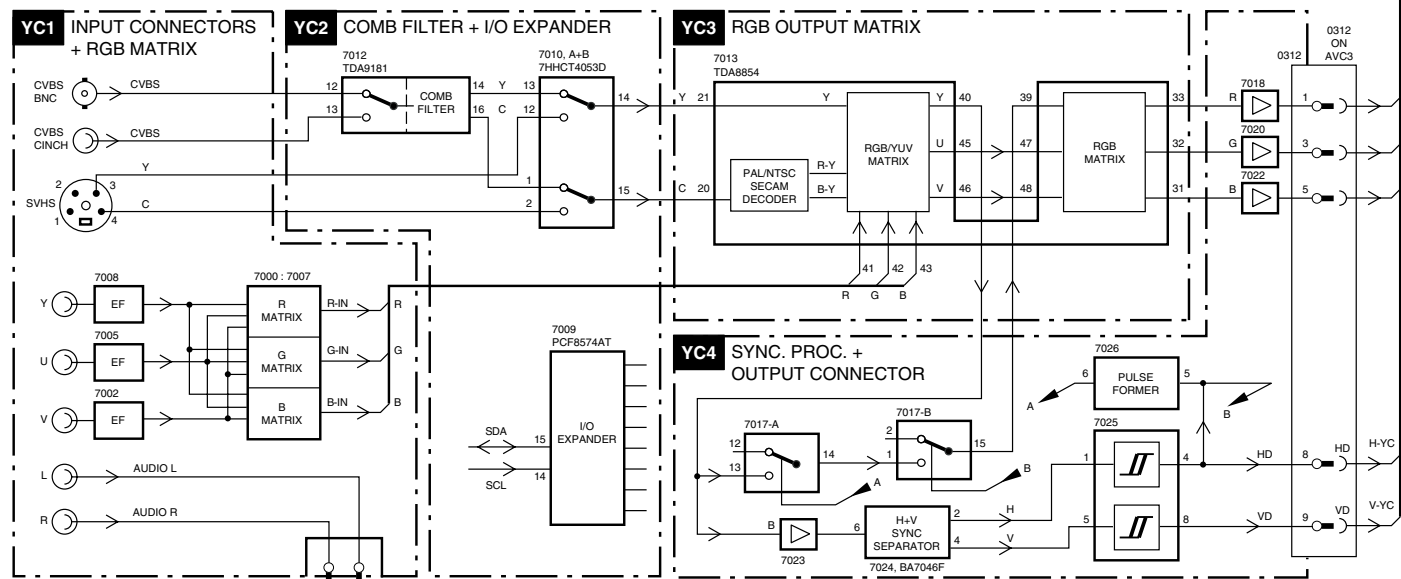
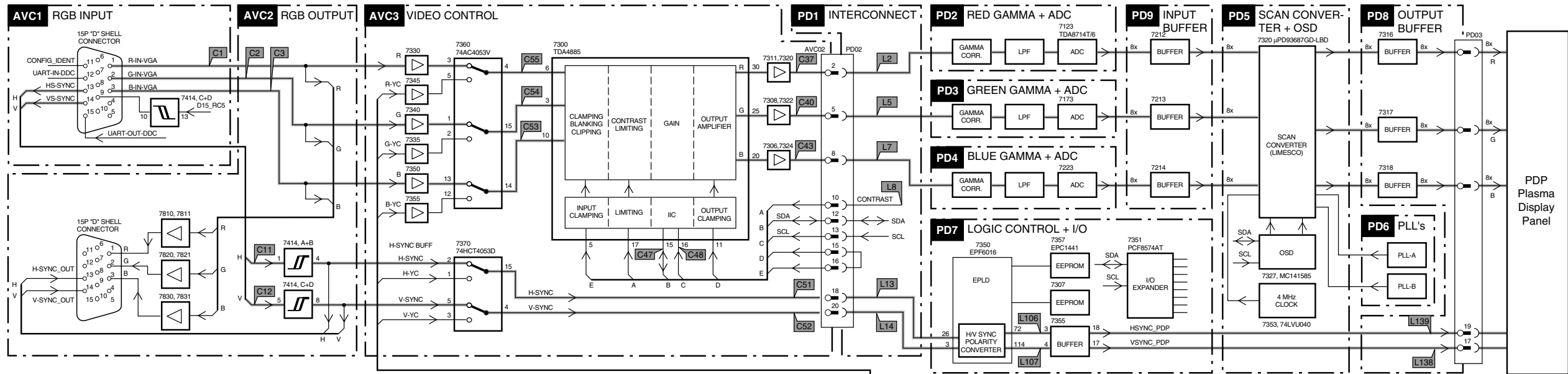
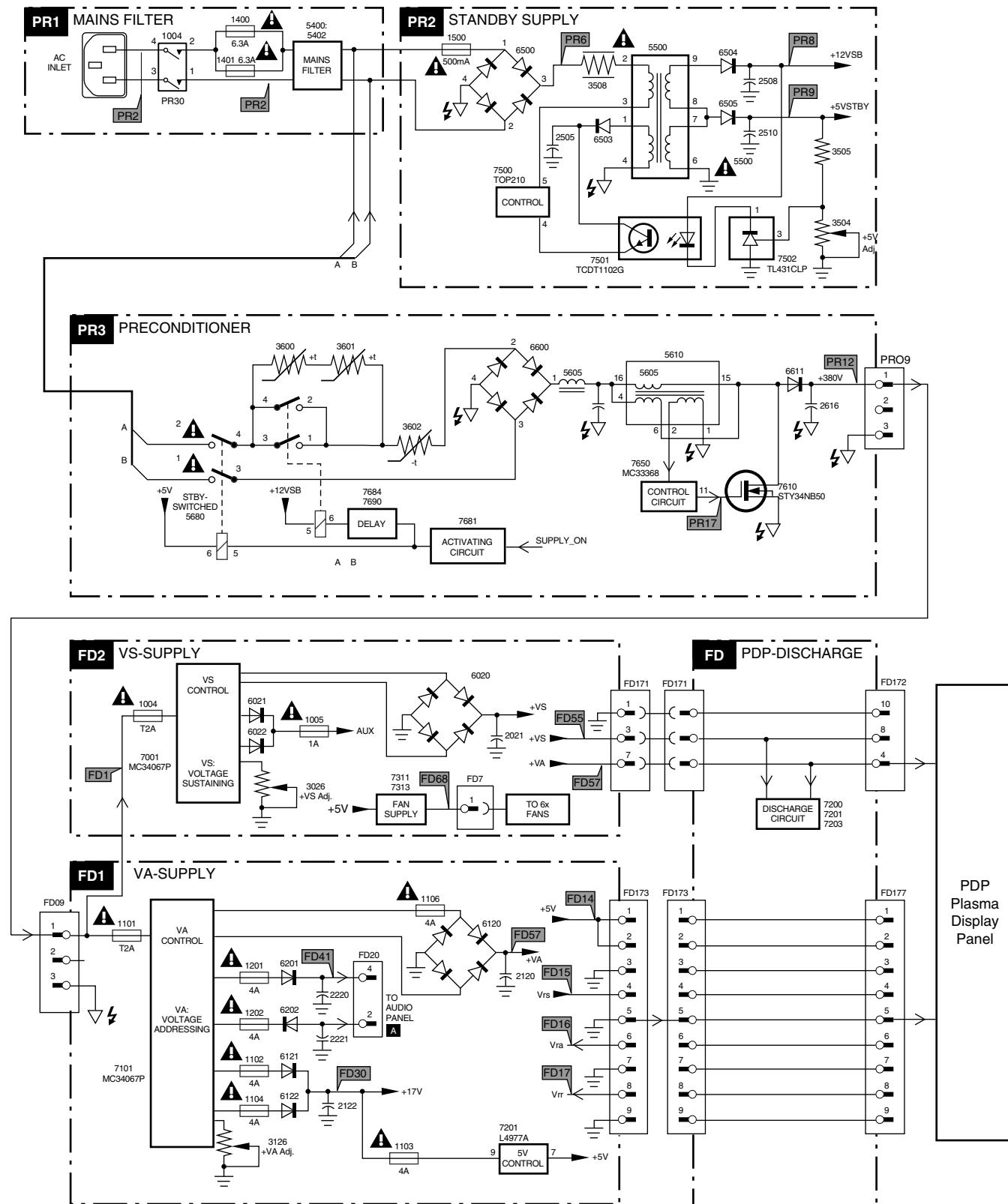

CL 96532058_17B.eps
280999

I2C bus interconnection diagram

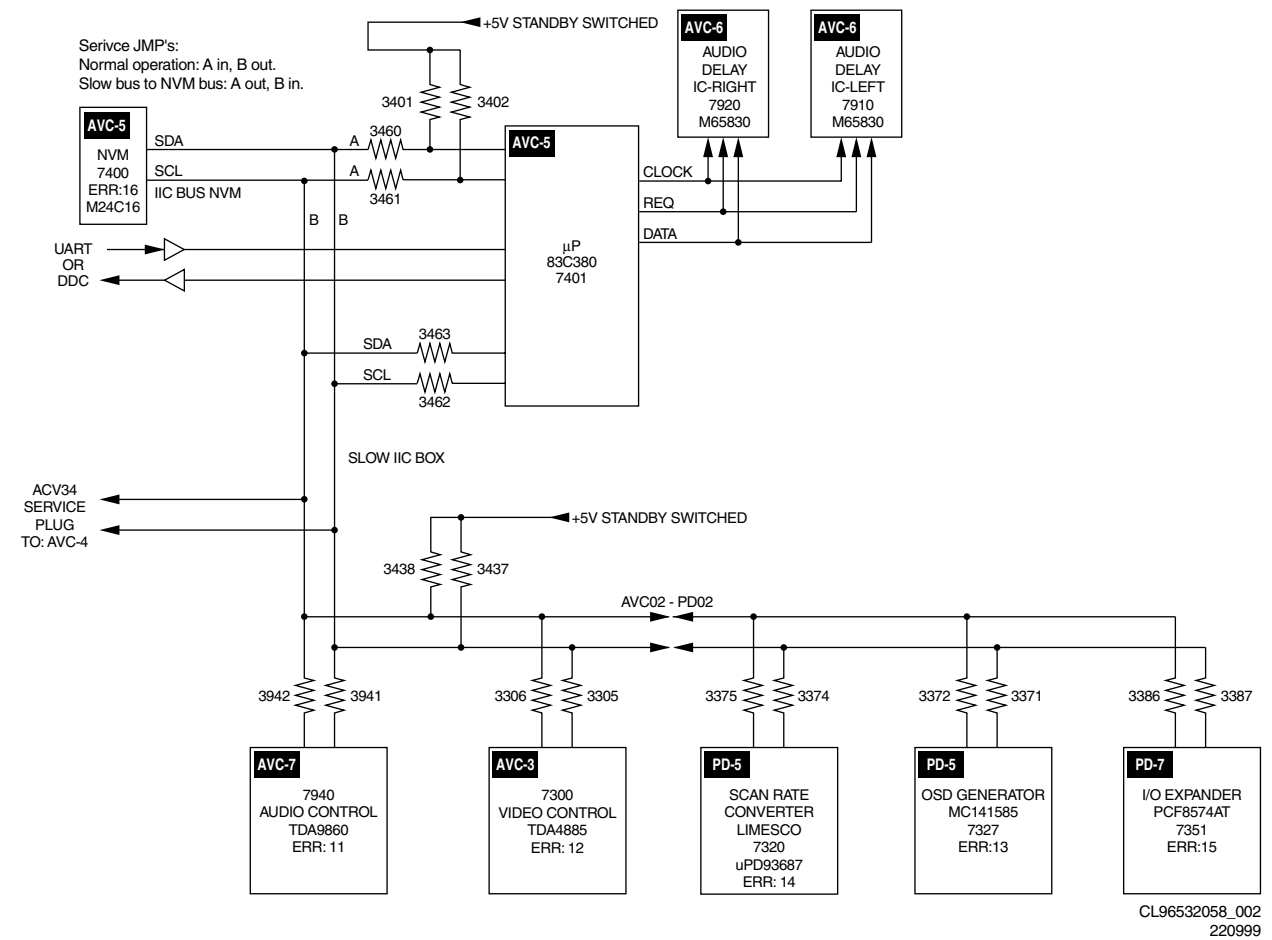

Testpoint overview AV Control

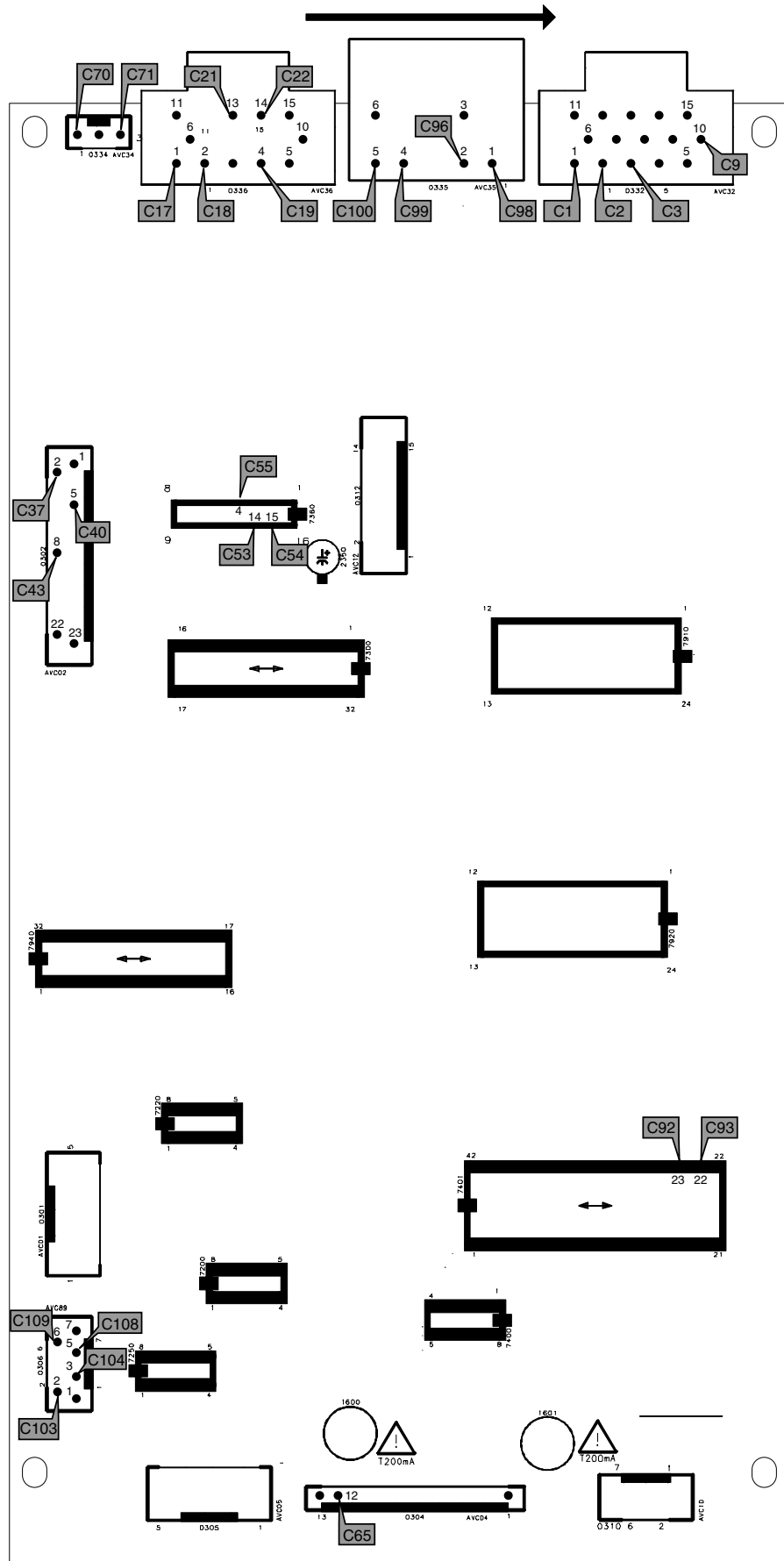

Testpoint overview Limesco

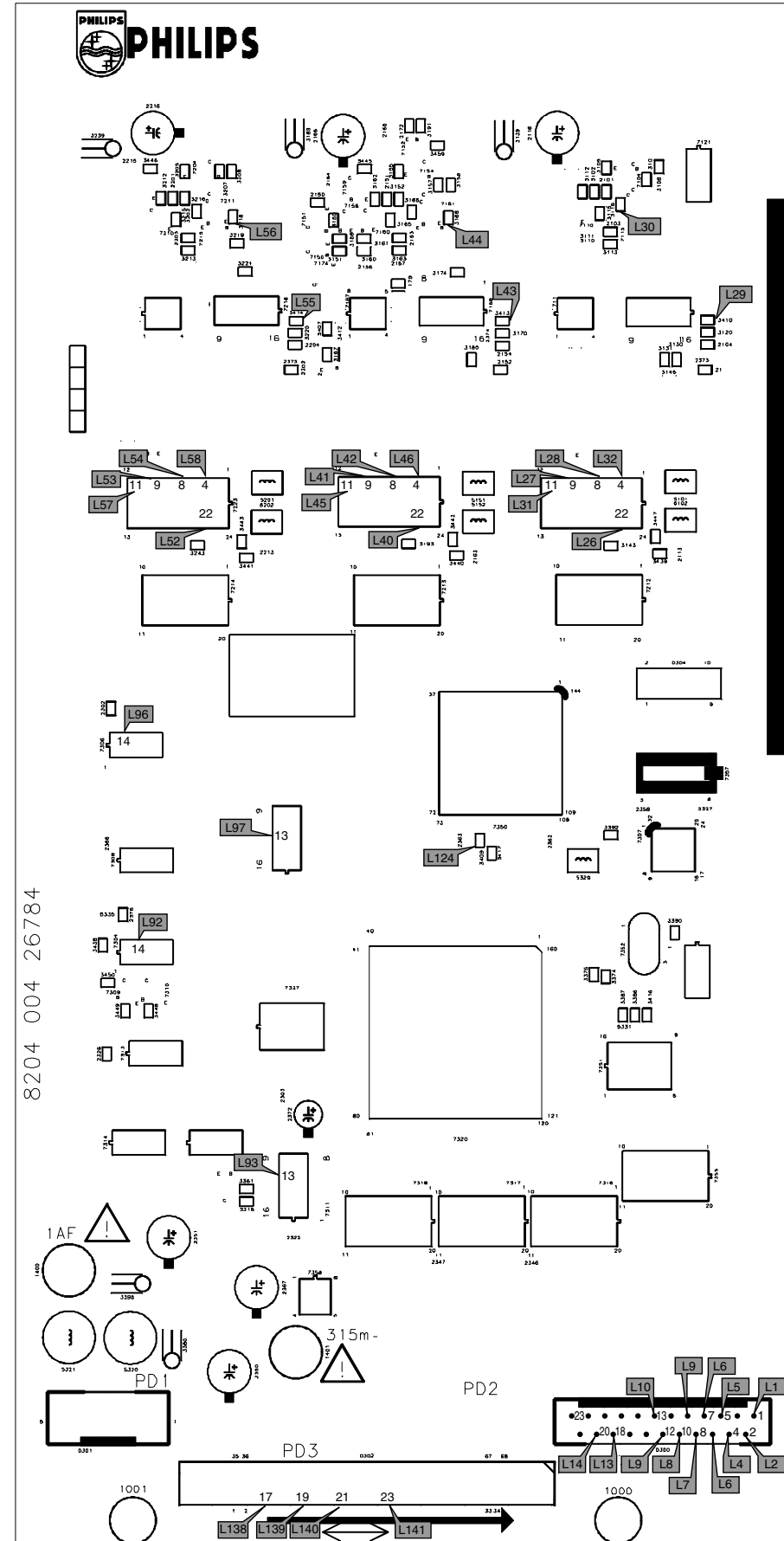

8204 004 26784

Testpoint overview Preconditioner

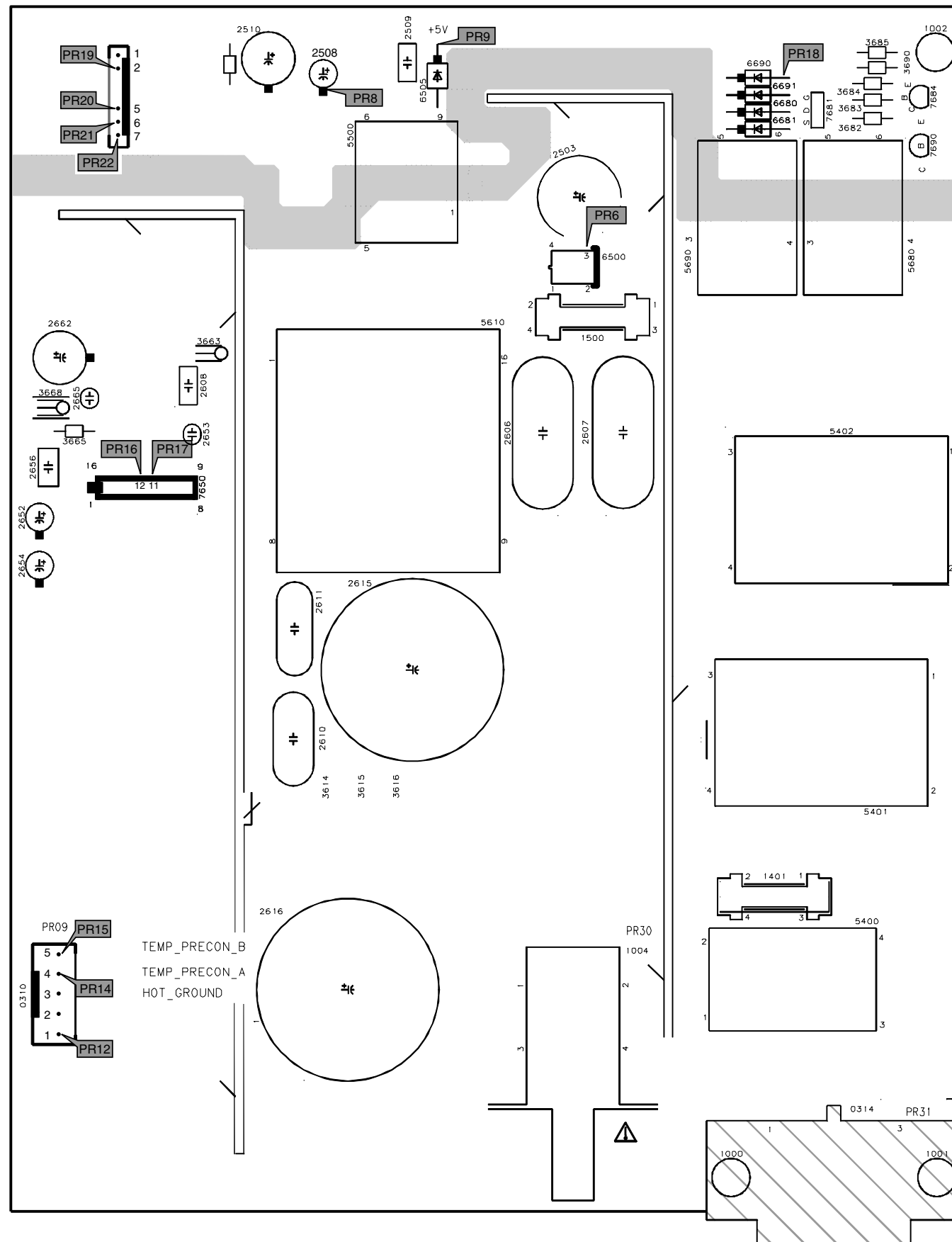

Testpoint overview VsVa Supply

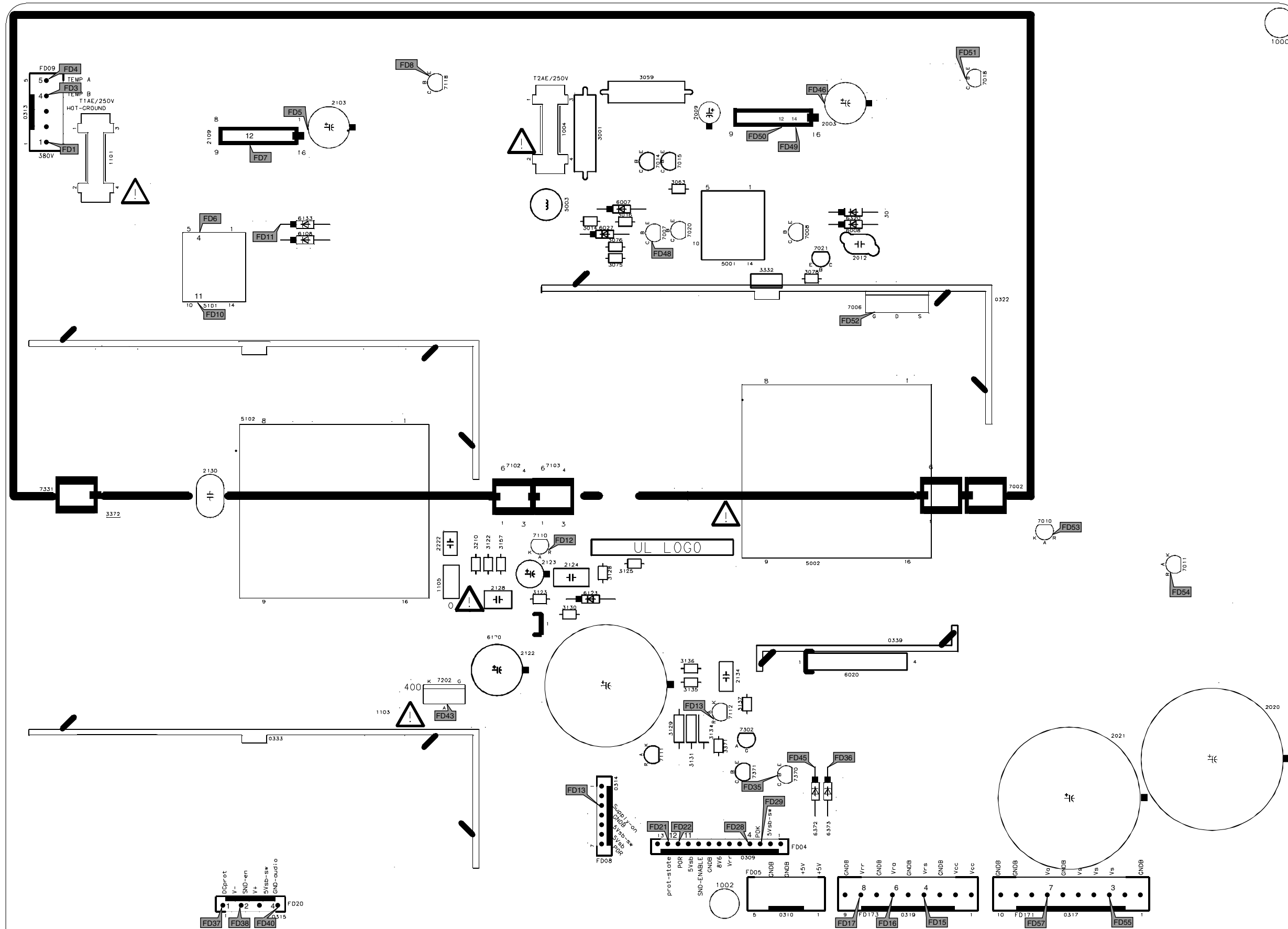

Oscillograms

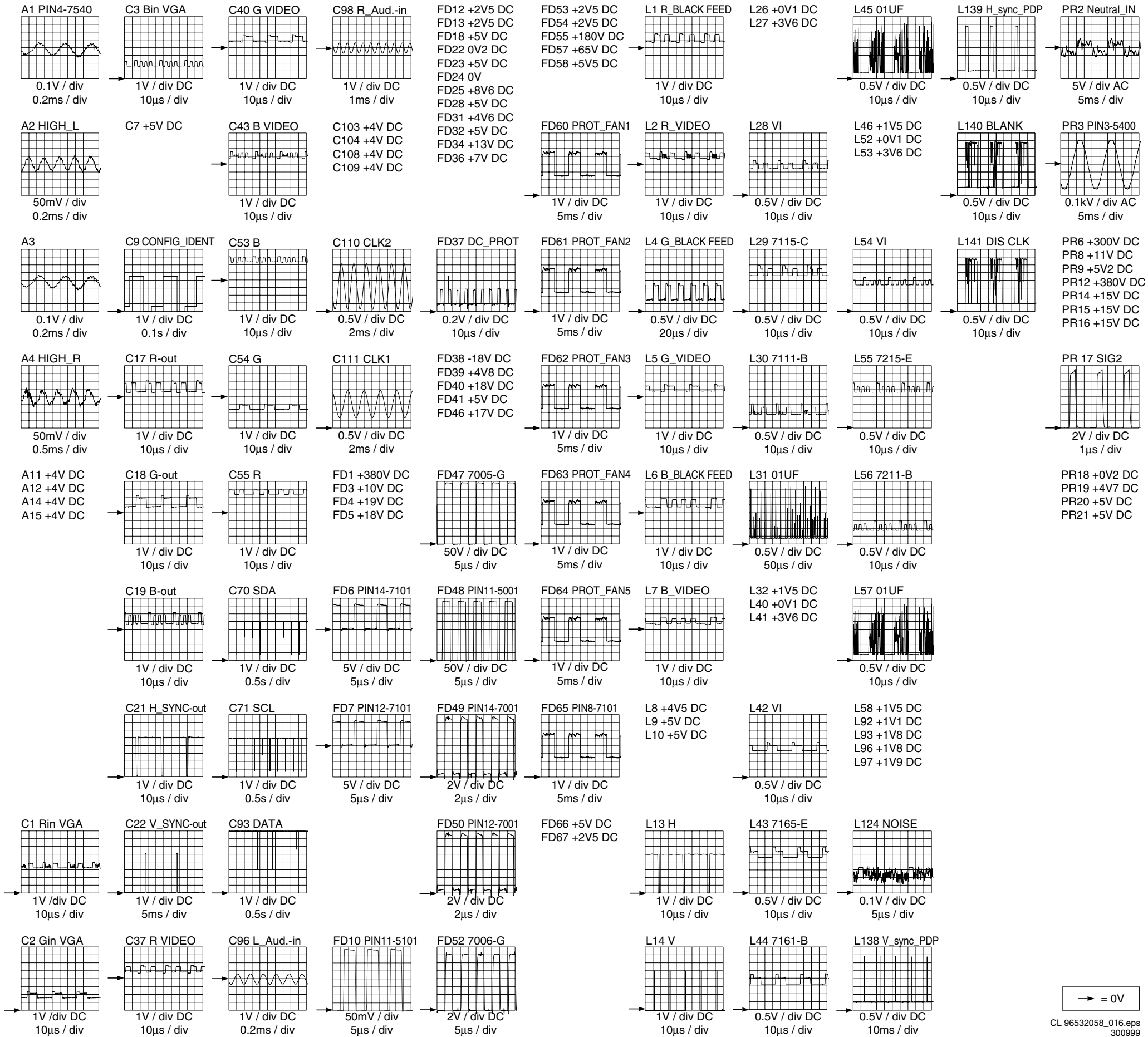

→ = 0V

Supply voltage diagram

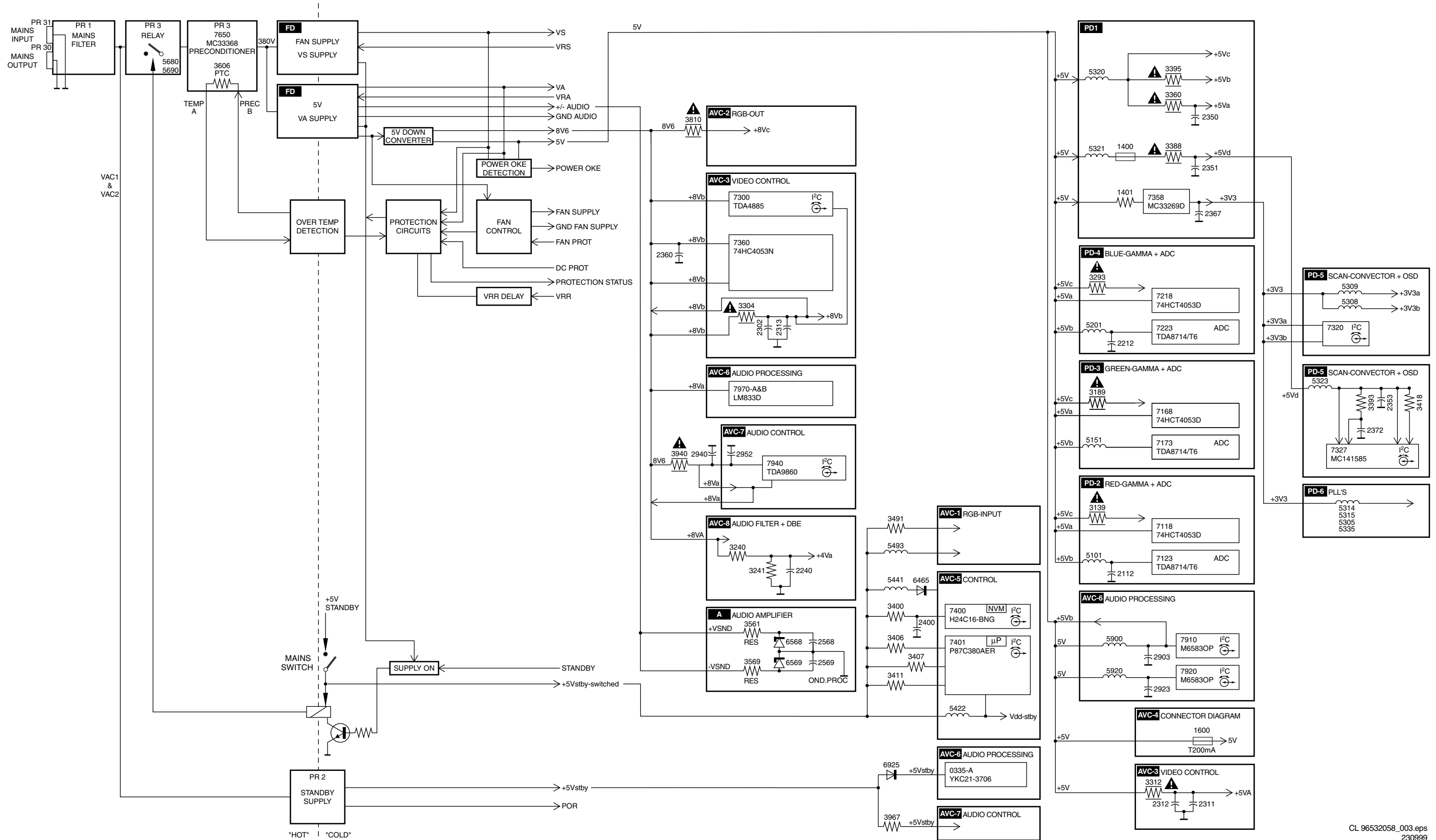

Wiring diagram

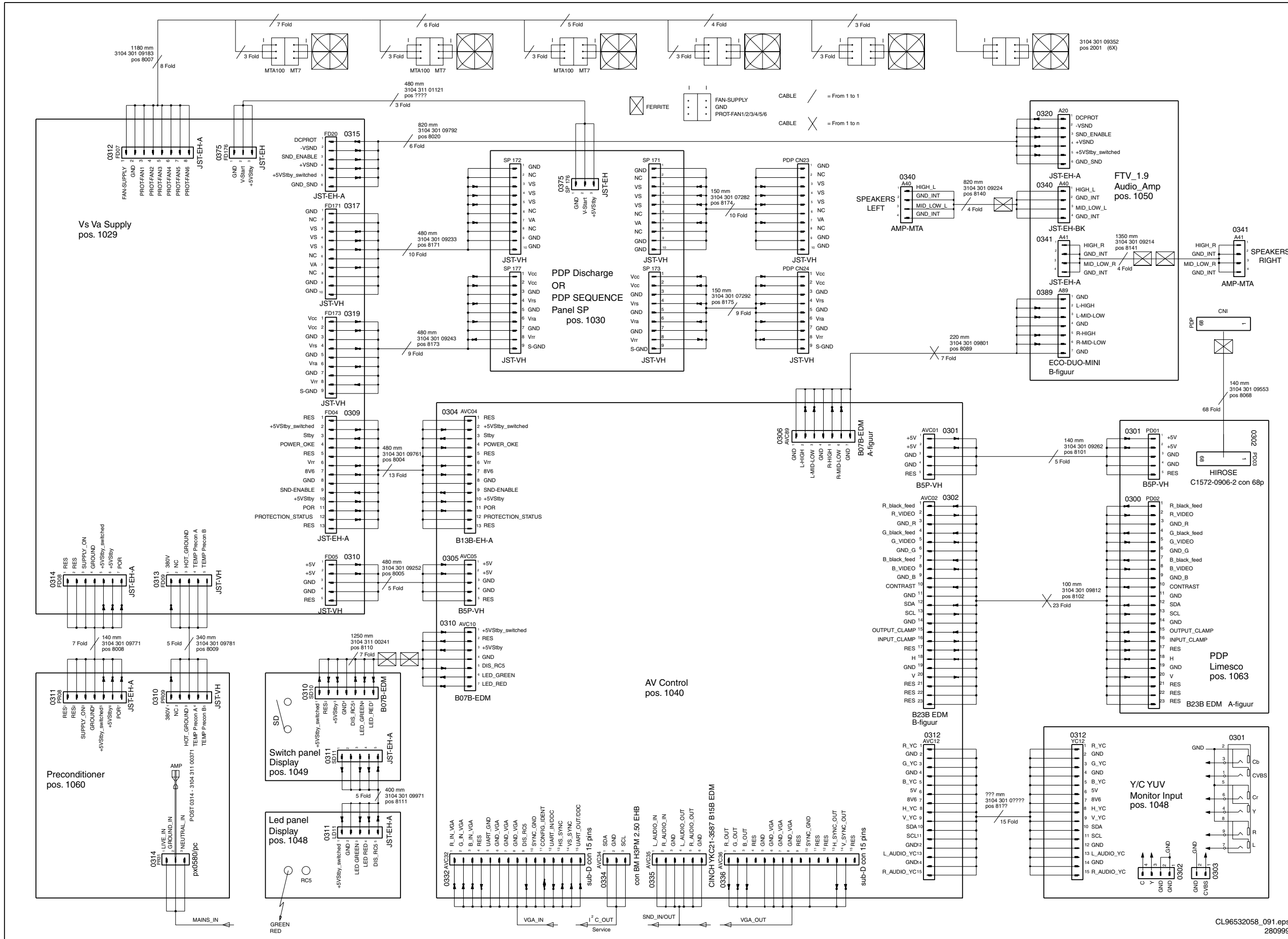

7. Electrical diagrams and print layouts

VsVa supply (FD)

0309 G15	2103 A5	2122 C10	2204 G7	2224 G9	3111 B5	3128 C12	3170 D3	3207 H7	3331 F1	3371 E14	5201 F10	6112 C4	6205 G10	7109 C3	7301-B F13
0310 E15	2104 A1	2123 B10	2205 G8	2202 E11	3112 E3	3129 B12	3171 A8	3210 E7	3332 G1	3372 G4	5202 G6	6120 A10	6207 G9	7110 C11	7302 F13
0313 A1	2105 B2	2124 B11	2206 H8	2316 H4	3113 E4	3130 B12	3172 B8	3211 G9	3333 H1	3373 G4	5203 D9	6121 B10	6306 E12	7111 B12	7303-A G2
0314 H15	2106 B2	2125 A12	2207 H8	2320 G9	3114 A7	3131 B12	3173 C8	3212 G8	3334 G2	3379 B15	5204 E9	6122 C10	6330 H11	7112 B13	7303-B F8
0315 D10	2107 D2	2126 F3	2208 G8	2324 G15	3115 A7	3132 C13	3174 C8	3213 G7	3335 H2	3384 A15	5205 E9	6123 B12	6331 G11	7113 A13	7331 G4
0319 C15	2108 E4	2127 E3	2209 F9	3099 F10	3116 B7	3133 A13	3175 E4	3214 G9	3336 G3	3385 B15	5206 G9	6127 B7	6332 G12	7114 B14	7332 H4
0324 A9	2109 D3	2128 A10	2210 F9	3100 D6	3117 C7	3134 B13	3176 E3	3215 H6	3337 H4	3386 B15	5207 F11	6128 C7	6333 G12	7117 E3	7335 H12
0333 G10	2110 D4	2129 C10	2211 G10	3101 A4	3118 C7	3135 A13	3177 D5	3216 H7	3338 G4	3387 H15	5208 G10	6130 A8	6370 G14	7118 E2	7336 G13
1101 A3	2111 C9	2130 E6	2212 F11	3102 A5	3119 C7	3136 A14	3180 C3	3217 H8	3339 G5	3390 E13	6101 A7	6131 B8	6372 H14	7120 B8	7337 G5
1102 B9	2112 C8	2131 C10	2213 F11	3103 A4	3120 C3	3137 B14	3181 C4	3301 E12	3360 G11	6102 A6	6132 C8	6373 H13	7121 C8	7341 B15	
1103 G6	2113 A8	2132 C14	2214 H7	3104 B1	3121 D5	3138 C14	3182 C5	3302 E12	3361 H11	6104 B5	6133 D8	7101 A2	7122 E5	7370 H14	
1104 C9	2114 C5	2133 A6	2215 E8	3105 B2	3122 B11	3139 A14	3201 F7	3303 E12	3362 G11	6105 B5	6134 E5	7102 B11	7201 F7	7371 F14	
1105 A10	2115 C4	2134 B13	2216 E8	3106 B2	3123 B11	3140 C3	3202 G7	3304 E13	3363 H11	6107 A7	6135 C2	7103 B15	7202 H6	7372 G7	
1201 D8	2116 C2	2135 B14	2220 E8	3107 C2	3124 A12	3157 B10	3203 H8	3305 F12	3364 G12	6101 B6	6201 E8	7105 A8	7203 F11		
1202 E8	2117 C3	2201 F8	2221 E8	3108 C2	3125 C12	3164 E3	3204 G8	3306 F12	3365 H12	6102 C9	6202 E8	7106 B8	7204 H7		
2101 A7	2118 C4	2202 F7	2222 D7	3109 D2	3126 D11	3165 D2	3205 G9	3307 G13	3366 G12	6110 D4	6203 G9	7107 B7	7205 H8		
2102 A6	2120 A11	2203 G7	2223 G9	3110 B5	3127 A12	3166 D3	3206 F8	3308 F13	3370 G14	6111 D4	6204 F10	7108 D7	7301-A E13		

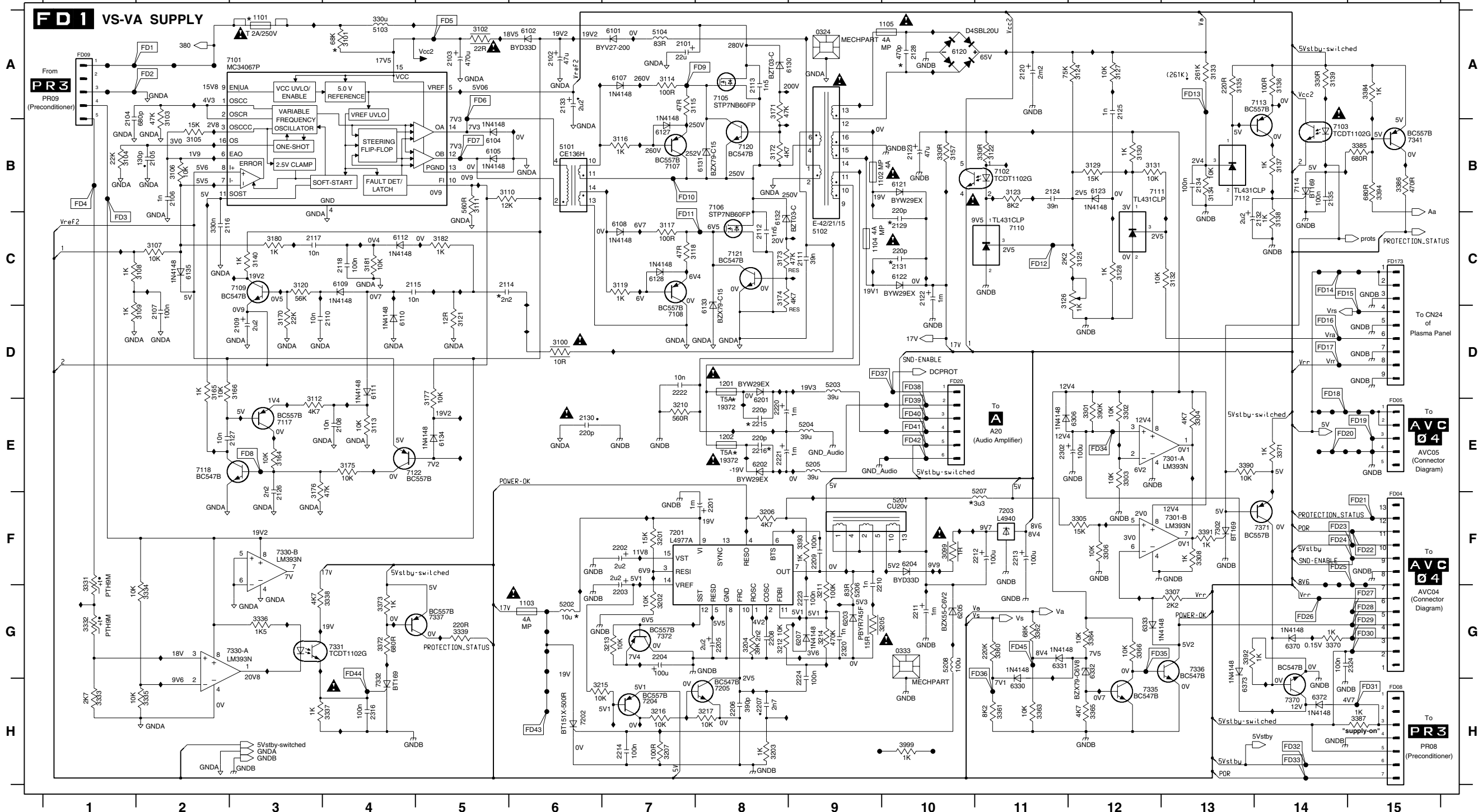

VsVa supply (FD)

0312 E15	2009 D5	2026 E3	2307 E12	3002 A5	3019 D8	3035 A14	3056 D3	3072 F2	3320 G6	3355 H10	5002 C9	6024 A3	6311 D11	6340 D12	7010 B11	7315 H9
0317 B15	2010 D4	2027 E2	2308 F11	3003 C2	3019 D7	3036 A14	3057 A11	3073 F4	3321 G6	3356 H14	5003 A5	6025 A4	6312 E11	6341 E12	7011 B13	7316 D12
0318 D15	2011 D9	2028 A10	2309 F12	3004 C1	3020 D4	3037 C13	3058 A13	3074 E5	3322 G7	3357 H15	5004 A7	6026 A4	6313 F11	6342 F12	7012 A14	7317 E12
0322 A9	2012 C8	2029 B10	2310 G11	3005 C2	3021 D5	3038 C14	3059 A5	3075 B9	3323 G10	3374 H6	6001 A6	6027 B8	6314 G11	6343 G12	7013 C14	7318 F12
0331 F5	2013 B8	2030 F9	2311 G12	3006 C2	3022 A11	3039 B14	3060 A3	3076 C9	3324 G8	3375 H6	6002 A6	6028 D8	6315 H11	6344 H12	7014 A3	7319 G12
0339 A13	2014 D5	2032 C14	2312 H11	3007 E2	3023 B11	3040 A12	3061 B3	3077 D9	3325 H9	3376 H6	6004 C5	6029 F4	6316 H13	6345 H15	7015 B4	7320 H12
1004 A2	2015 D5	2033 D1	2313 H12	3008 E2	3024 A12	3041 C12	3062 A4	3078 D9	3340 D12	3377 H7	6005 C5	6030 A7	6317 B9	6371 F8	7016 A14	7321 G8
1005 B10	2016 D2	2034 D1	2314 H10	3009 E2	3025 C12	3042 D1	3063 A4	3079 D9	3341 G1	3378 H7	6007 B7	6031 D2	6318 C8	6374 C14	7017 D3	7322 H14
2001 A6	2017 F3	2035 E1	2315 G7	3010 C6	3026 C12	3043 C1	3064 E3	3079 D9	3342 E1	3379 H7	6008 C7	6032 D2	6319 C9	7001 B2	7018 E3	7333 H5
2002 B6	2018 F4	2036 C2	2317 H5	3011 D5	3027 E3	3044 D1	3065 E2	3079 D9	3343 G1	3380 F8	6009 D4	6033 E1	6320 D8	7002 B1	7019 E6	7338 H6
2003 B5	2020 A11	2037 B13	2318 H5	3012 E3	3029 B12	3045 D1	3066 D2	3079 D9	3344 E1	3381 F8	6010 D4	6034 C2	6321 D11	7003 C14	7020 B8	7339 H6
2004 C1	2021 A12	2038 C14	2319 H14	3013 E4	3030 B13	3046 E1	3067 D3	3079 D9	3345 G2	3382 F8	6011 E4	6301 G2	6322 E11	7005 B8	7021 D8	7340 F8
2005 C1	2022 C10	2303 G2	2321 H7	3014 B8	3031 B13	3047 E2	3068 D7	3079 D9	3315 G2	3383 G9	6012 D7	6302 G4	6323 F11	7006 C8	7311-A H2	
2006 C2	2023 A10	2304 D11	2322 H6	3015 B8	3032 C13	3048 D1	3069 D6	3079 D9	3316 G3	3384 H7	6020 A11	6303 G4	6324 G11	7007 C8	7311-B G5	
2007 E2	2024 B12	2305 D12	2323 H5	3016 B7	3033 A13	3049 D2	3070 D6	3079 D9	3317 G4	3389 H6	6021 B10	6304 G6	6325 H11	7008 D8	7313 G5	
2008 E4	2025 A12	2306 E11	3001 A5	3017 C8	3034 B13	3050 E7	3071 E5	3318 G5	3353 H12	5001 C6	6023 B12	6305 G7	6326 H14	7009 D3	7314 F8	

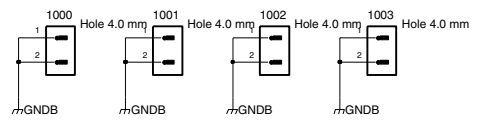
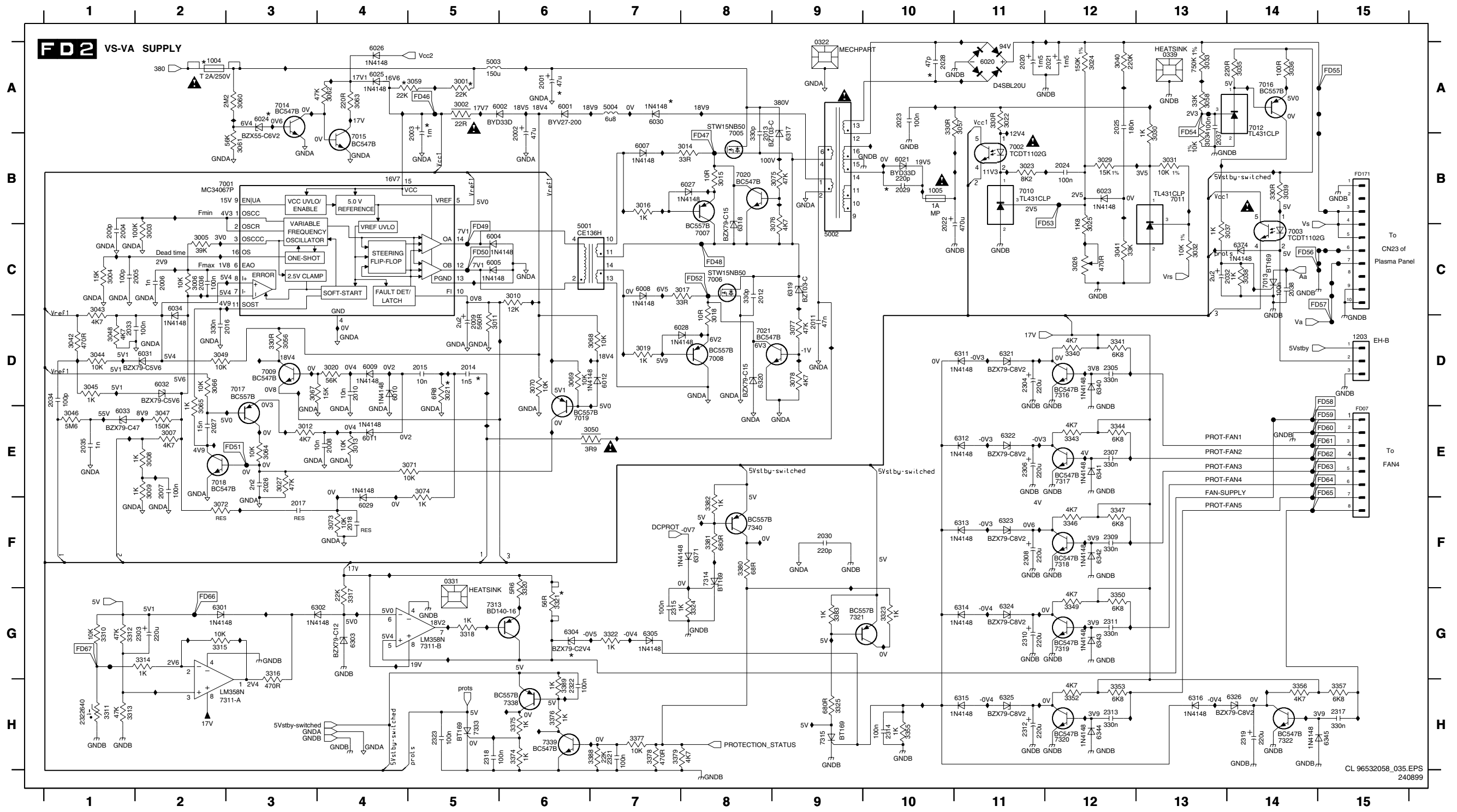

VsVa supply (FD) copper side

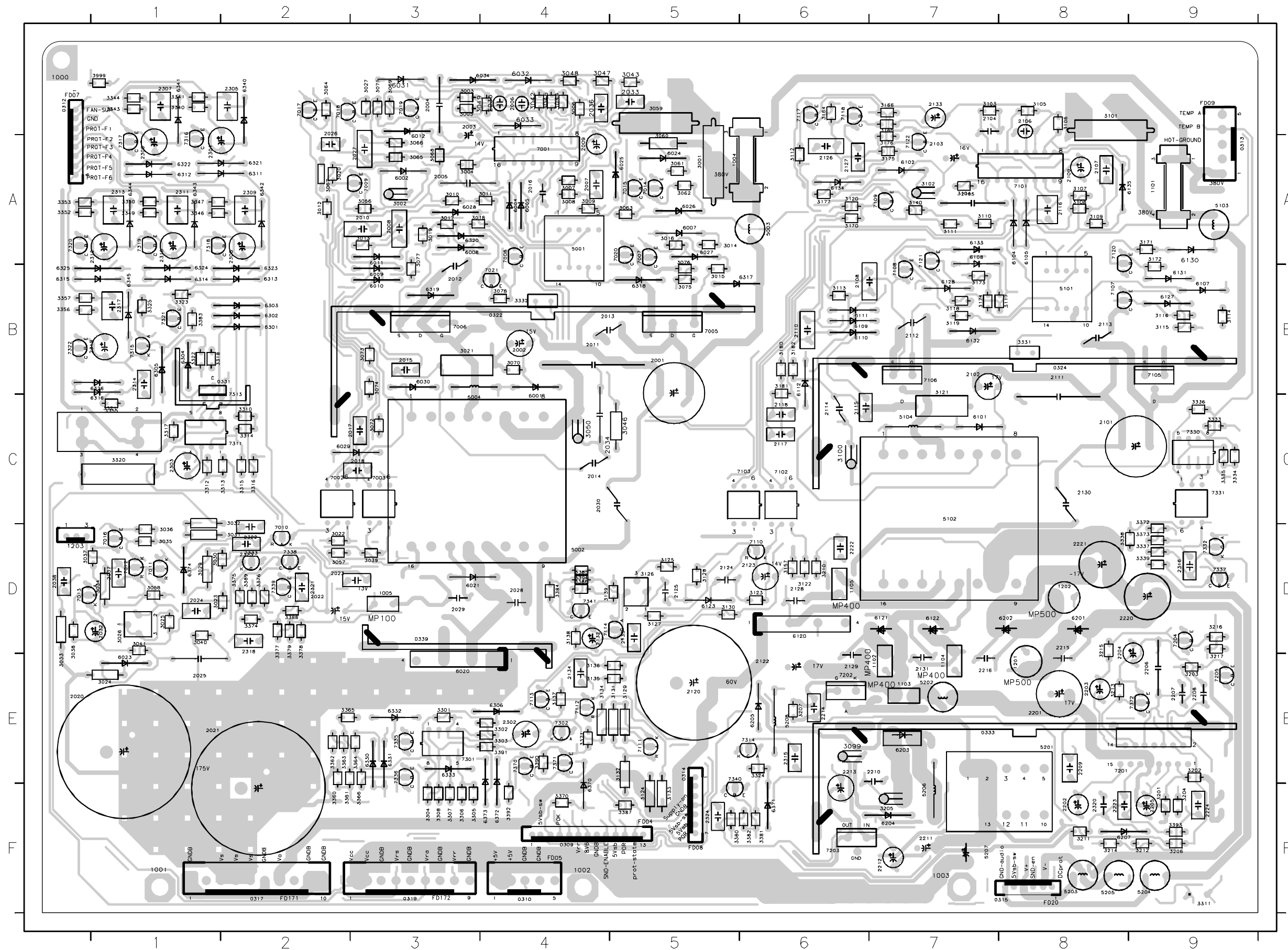

Pre conditioner (PR)

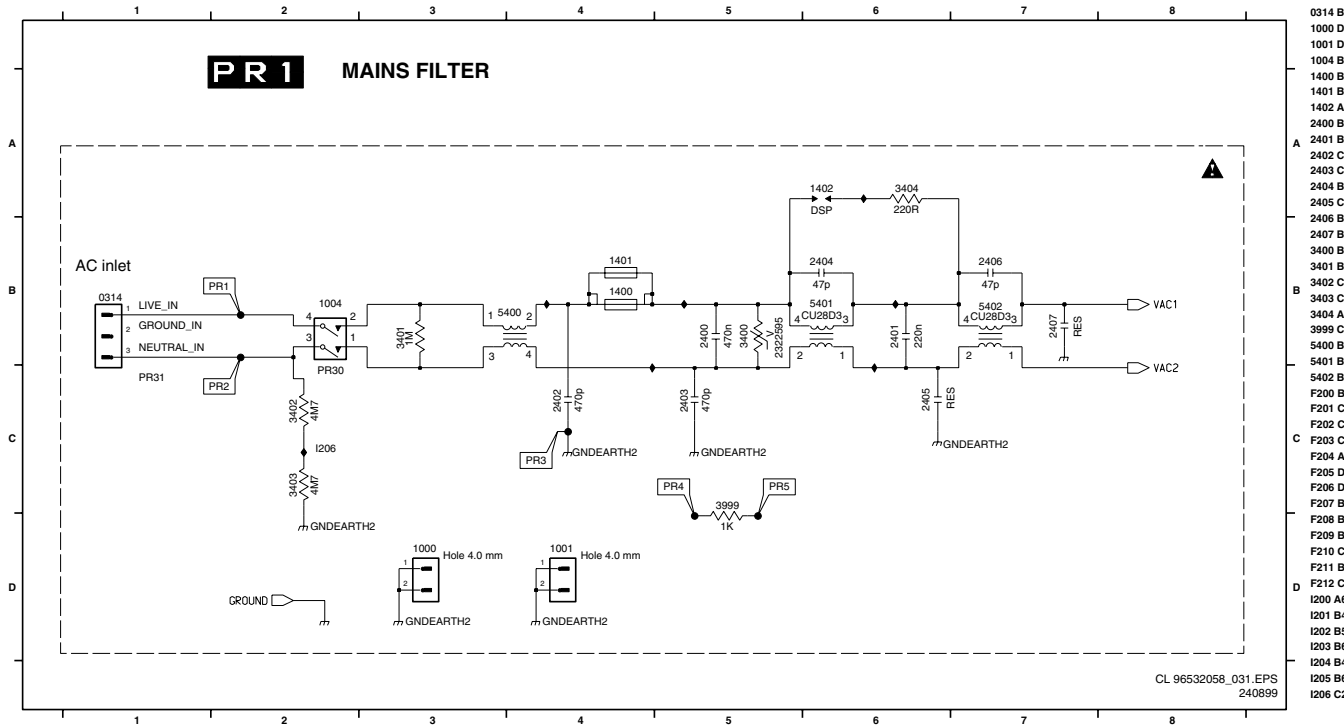

- 0314 B1
- 1000 D3
- 1001 D4
- 1004 B2
- 1400 B4
- 1401 B4
- 1402 A6
- 2400 B5
- 2401 B6
- 2402 C4
- 2403 C5
- 2404 B6
- 2405 C6
- 2406 B7
- 2407 B7
- 3400 B5
- 3401 B3
- 3402 C2
- 3403 C2
- 3404 A6
- 3999 C5
- 5400 B4
- 5401 B6
- 5402 B7
- F200 B2
- F201 C2
- F202 C4
- F203 C2
- F204 A2
- F205 D5
- F206 D5
- F207 B2
- F208 B2
- F209 B2
- F210 C2
- F211 B2
- F212 C2
- I200 A6
- I201 B4
- I202 B5
- I203 B6
- I204 B4
- I205 B6
- I206 C2

Pre conditioner (PR)

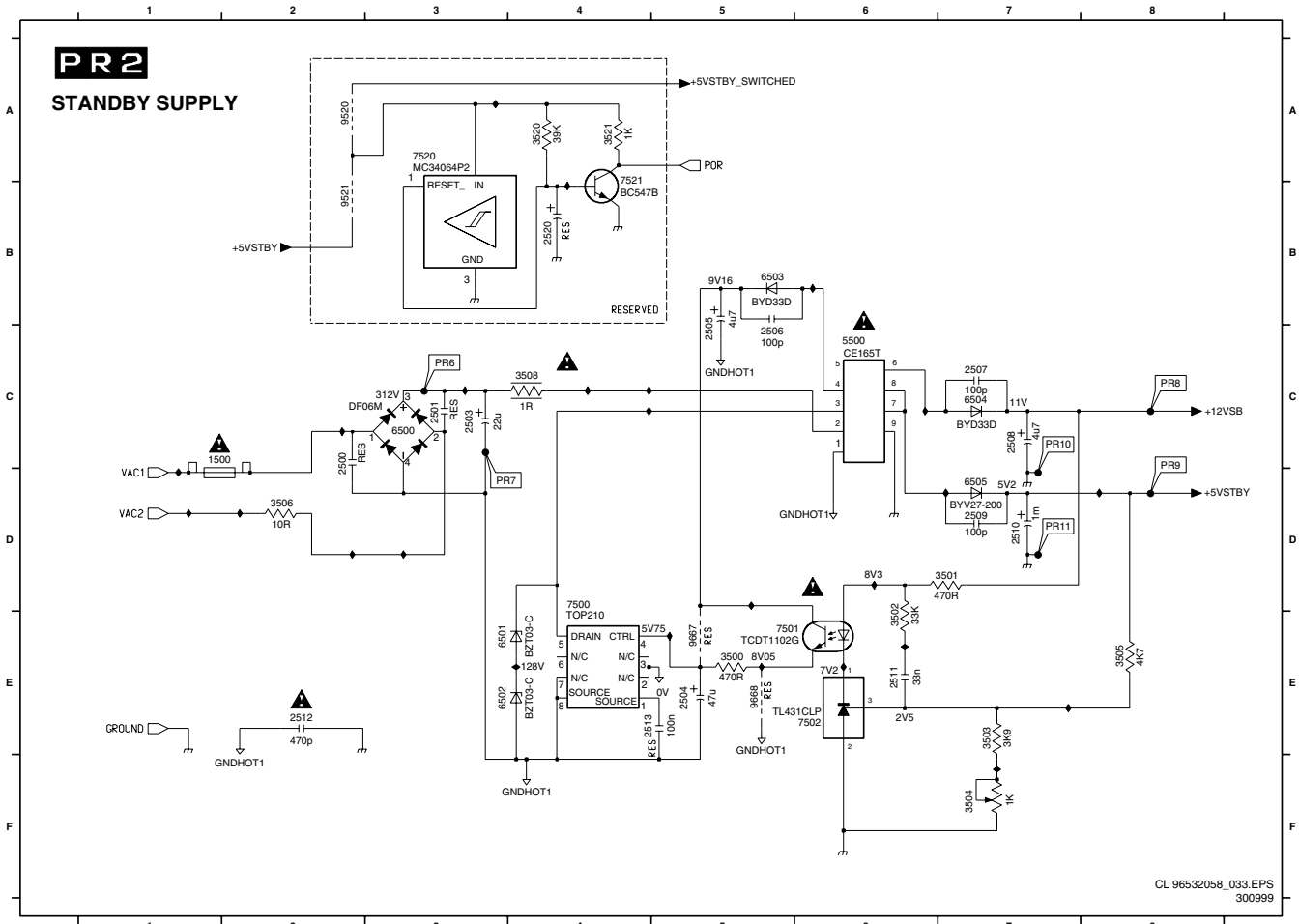

- 1500 C1
- 2500 C2
- 2501 C3
- 2503 C3
- 2504 E5
- 2505 C5
- 2506 C5
- 2507 C7
- 2508 C7
- 2509 D7
- 2510 D7
- 2511 E6
- 2512 E2
- 2513 E5
- 2520 B4
- 3500 E5
- 3501 D7
- 3502 E6
- 3503 E7
- 3504 F7
- 3505 E8
- 3506 D2
- 3508 C4
- 3520 A4
- 3521 A4
- 3500 C5
- 6500 C3
- 6501 E3
- 6502 E3
- 6503 B5
- 6504 C7
- 6505 D7
- 7500 D4
- 7501 E6
- 7502 E5
- 7520 A4
- 7521 B4
- 9520 A2
- 9521 B2
- 9567 E5
- 9568 E5
- F300 C3
- F301 C8
- F302 D7
- F303 C7
- F304 D7
- F305 C3
- I300 A3
- I301 A4
- I303 C4
- I304 C6
- I306 C2
- I307 C4
- I308 C1
- I309 B6
- I310 D7
- I311 E3
- I312 D6
- I314 D5
- I316 E5
- I317 E5
- I318 E6
- I319 E7
- I320 F7
- I321 D1
- I322 D3
- I323 D2
- I324 C4
- I325 C3
- I326 D2
- I327 D8

Pre conditioner (PR)

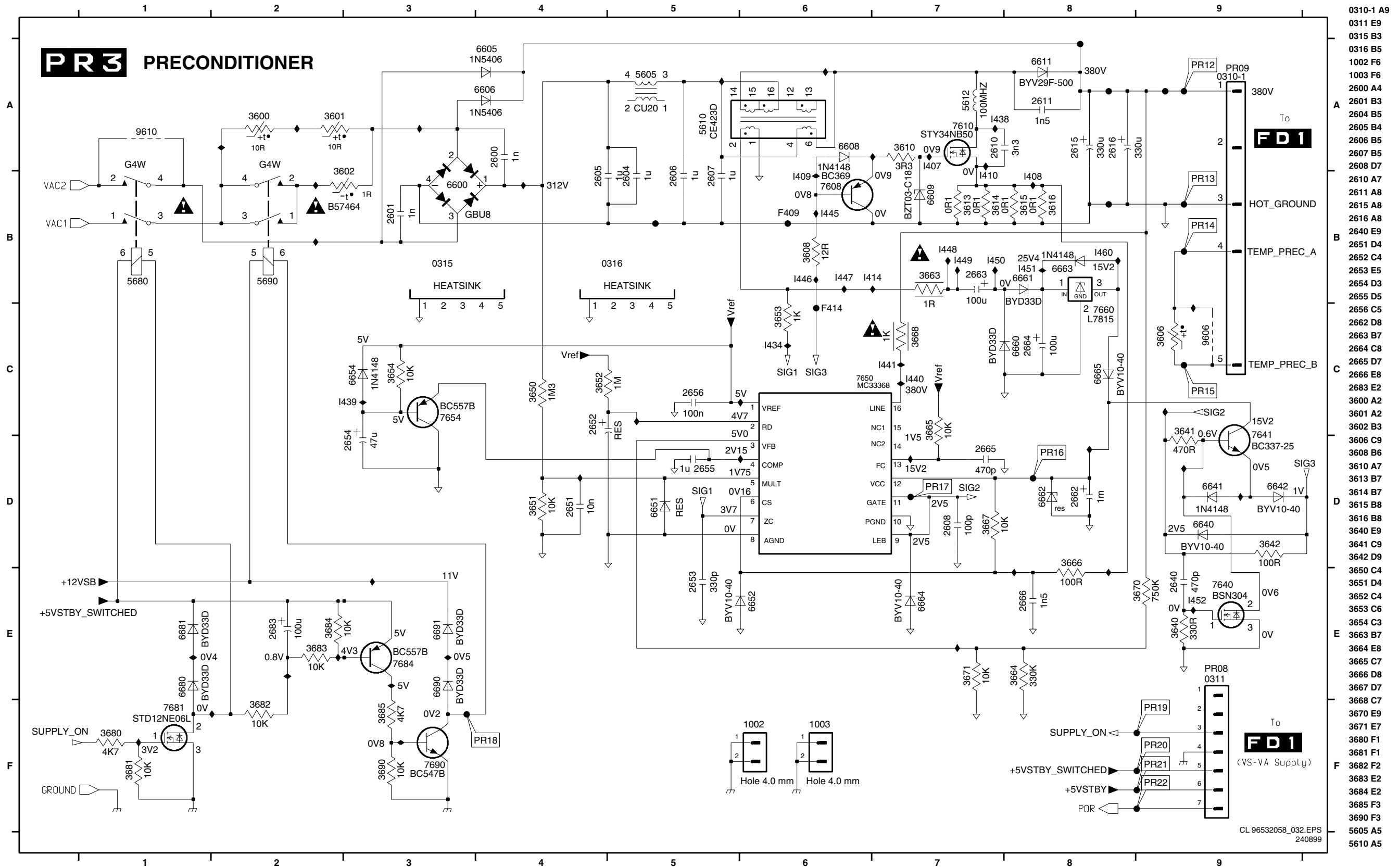

- 0310-1 A9
- 0311 E9
- 0315 B3
- 0316 B5
- 1002 F6
- 1003 F6
- 2600 A4
- 2601 B3
- 2604 B5
- 2605 B4
- 2606 B5
- 2607 B5
- 2608 D7
- 2610 A7
- 2611 A8
- 2615 A8
- 2616 A8
- 2640 E9
- 2651 D4
- 2652 C4
- 2653 E5
- 2654 D3
- 2655 D5
- 2656 C5
- 2662 D8
- 2663 B7
- 2664 C8
- 2665 D7
- 2666 E8
- 2683 E2
- 3600 A2
- 3601 A2
- 3602 B3
- 3606 C9
- 3608 B6
- 3610 A7
- 3613 B7
- 3614 B7
- 3615 B8
- 3616 B8
- 3640 E9
- 3641 C9
- 3642 D9
- 3650 C4
- 3651 D4
- 3652 C4
- 3653 C6
- 3654 C3
- 3663 B7
- 3664 E8
- 3665 C7
- 3666 D8
- 3667 D7
- 3668 C7
- 3670 E9
- 3671 E7
- 3680 F1
- 3681 F1
- 3682 F2
- 3683 E2
- 3684 E2
- 3685 F3
- 3690 F3
- 5605 A5
- 5610 A5
- 5612 A7
- 5680 B1
- 5690 B2
- 6600 B3
- 6605 A4
- 6606 A4
- 6608 A6
- 6609 B7
- 6611 A8
- 6640 D9
- 6641 D9
- 6642 D9
- 6651 D5
- 6652 E6
- 6654 C3
- 6660 C8
- 6661 B8
- 6662 D8
- 6663 B8
- 6664 E7
- 6665 C8
- 6680 E1
- 6681 E1
- 6690 E3
- 6691 E3
- 7608 B6
- 7610 A7
- 7640 E9
- 7641 D9
- 7650 C6
- 7654 C3
- 7660 C8
- 7681 F1
- 7684 E3
- 7690 F3
- 9606 C9
- 9610 A1

Pre conditioner (PR) component side

Pre conditioner (PR) copper side

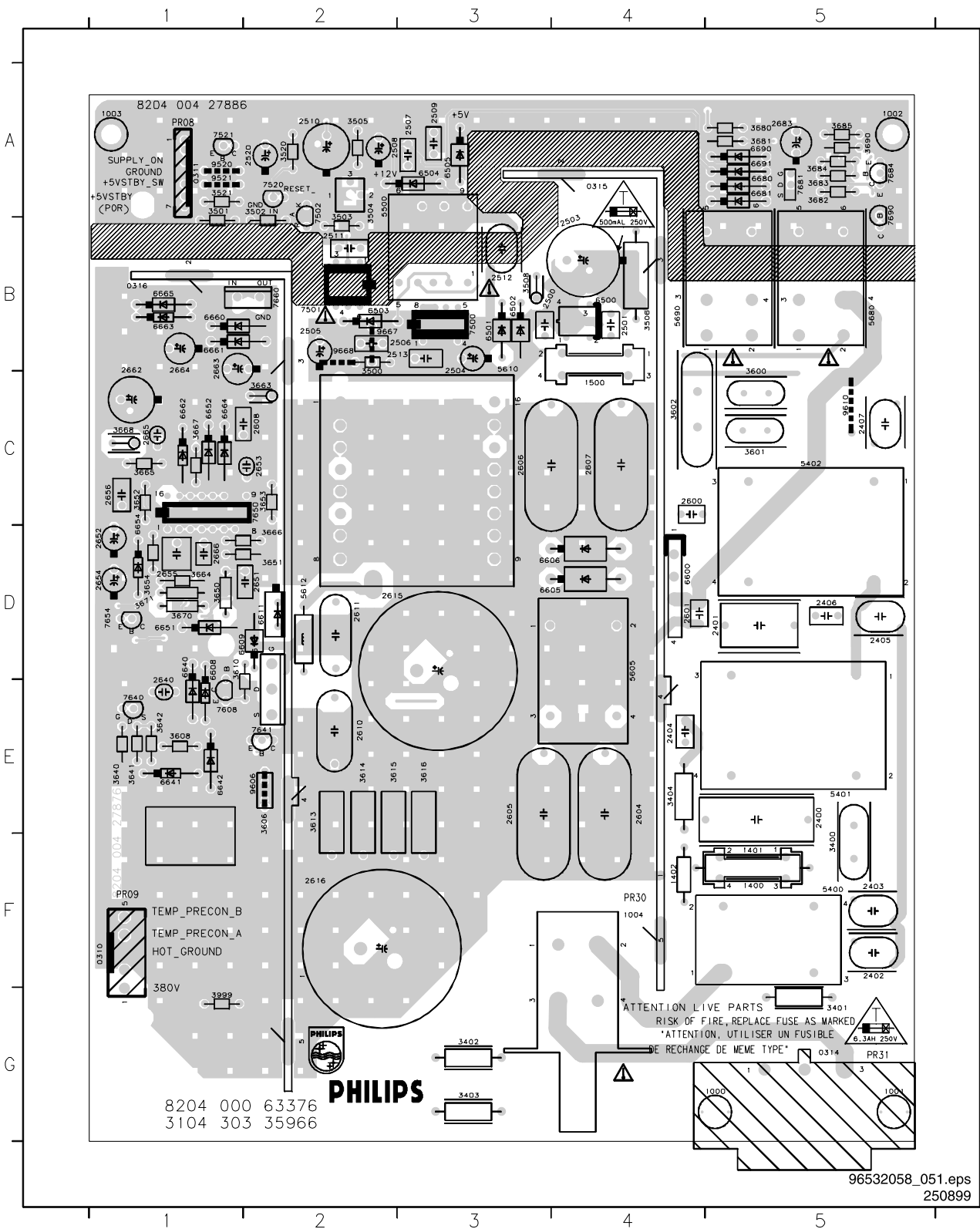

0310	F16651	D1
0311	A16652	C1
0314	C56654	C1
0315	A46660	B1
0316	B16661	B1
1004	F46662	C1
1400	F56663	C1
1401	F66664	C1
1402	F46665	B1
1500	C46680	A5
2400	E56681	A5
2401	D56690	A5
2402	F56691	A5
2403	F75000	B3
2404	E27500	B3
2405	D57500	A2
2406	D57520	A2
2407	C57521	A1
2500	B37608	E1
2501	B47610	D2
2503	B47640	D1
2504	B37641	F2
2505	B27650	C2
2506	B37654	D1
2507	A37660	B2
2508	A27681	A5
2509	A37684	A5
2510	A27690	A5
2511	B59200	A1
2512	B59201	A1
2513	B59202	A1
2514	B59203	A1
2520	A59610	C5
2600	C49667	B2
2601	D49668	B2
2605	E3	
2606	C3	
2607	C3	
2608	C3	
2610	F3	
2611	D3	
2615	D3	
2616	F3	
2640	F3	
2652	D1	
2653	C2	
2654	C2	
2655	D1	
2656	C1	
2657	B1	
2658	B1	
2664	B1	
2665	C1	
2666	C1	
2683	A5	
3400	F5	
3401	C5	
3402	C4	
3403	C3	
3404	F4	
3500	A1	
3501	A1	
3502	A2	
3503	A2	
3504	A2	
3505	A2	
3506	B4	
3508	B4	
3520	A2	
3521	A1	
3600	C5	
3601	C5	
3602	C4	
3606	F1	
3608	F1	
3610	D1	
3613	F1	
3614	F1	
3615	F1	
3616	F1	
3641	F1	
3642	F1	
3650	D1	
3651	D1	
3652	C1	
3653	C1	
3654	D1	
3664	C1	
3665	C1	
3666	D1	
3670	D1	
3671	D1	
3680	A5	
3681	A5	
3682	A5	
3683	A5	
3684	A5	
3685	A5	
3690	A5	
3999	G1	
5400	F5	
5401	E5	
5402	C5	
5500	A1	
5605	D4	
5610	B3	
5612	D2	
5680	B2	
5690	B4	
6500	B4	
6501	B3	
6502	B3	
6503	B2	
6504	A3	
6505	A3	
6600	D4	
6605	D3	
6606	D3	
6608	D1	
6609	D1	
6611	D2	
6640	D1	
6641	E1	
6642	E1	

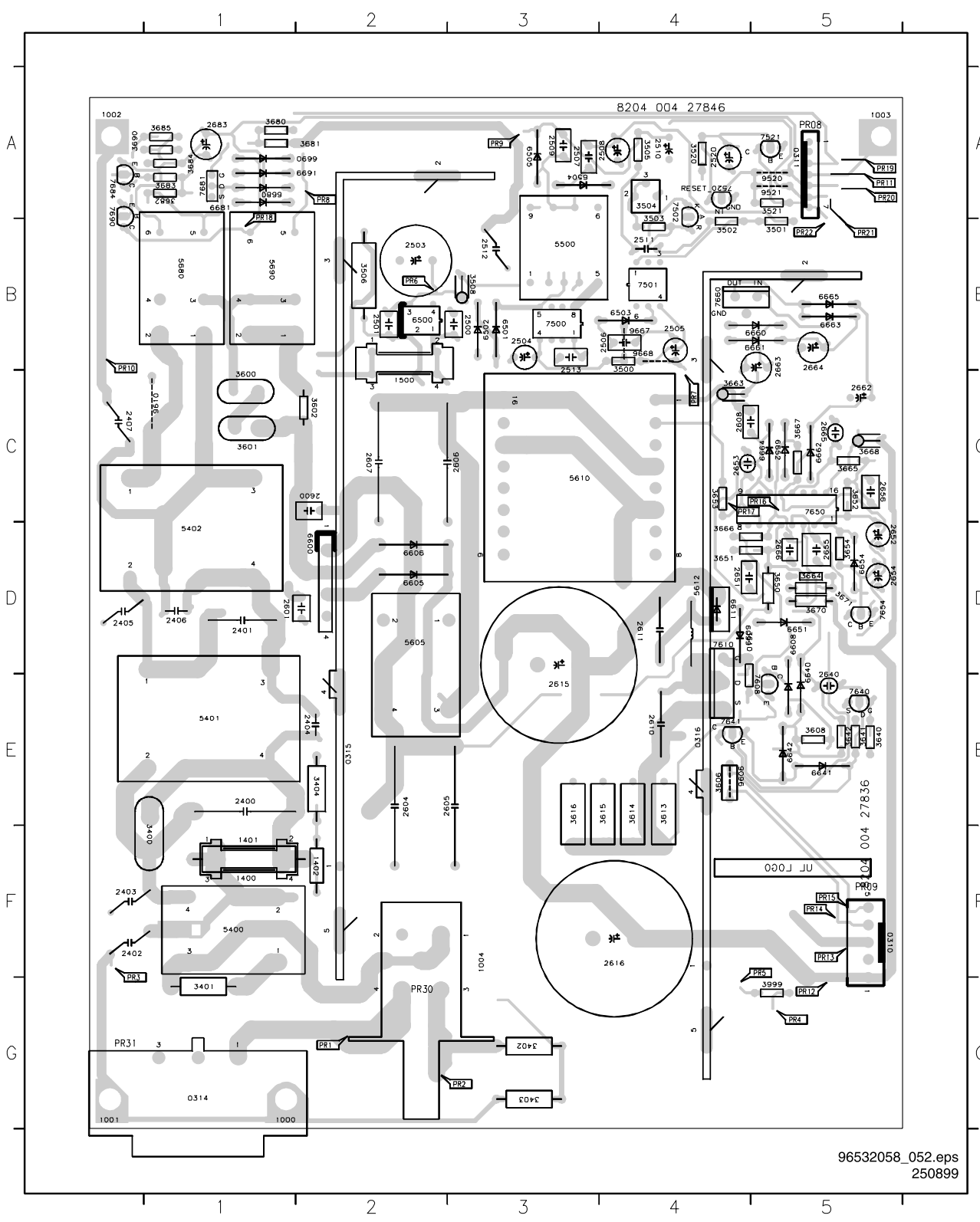

LED panel

LED panel (component side)

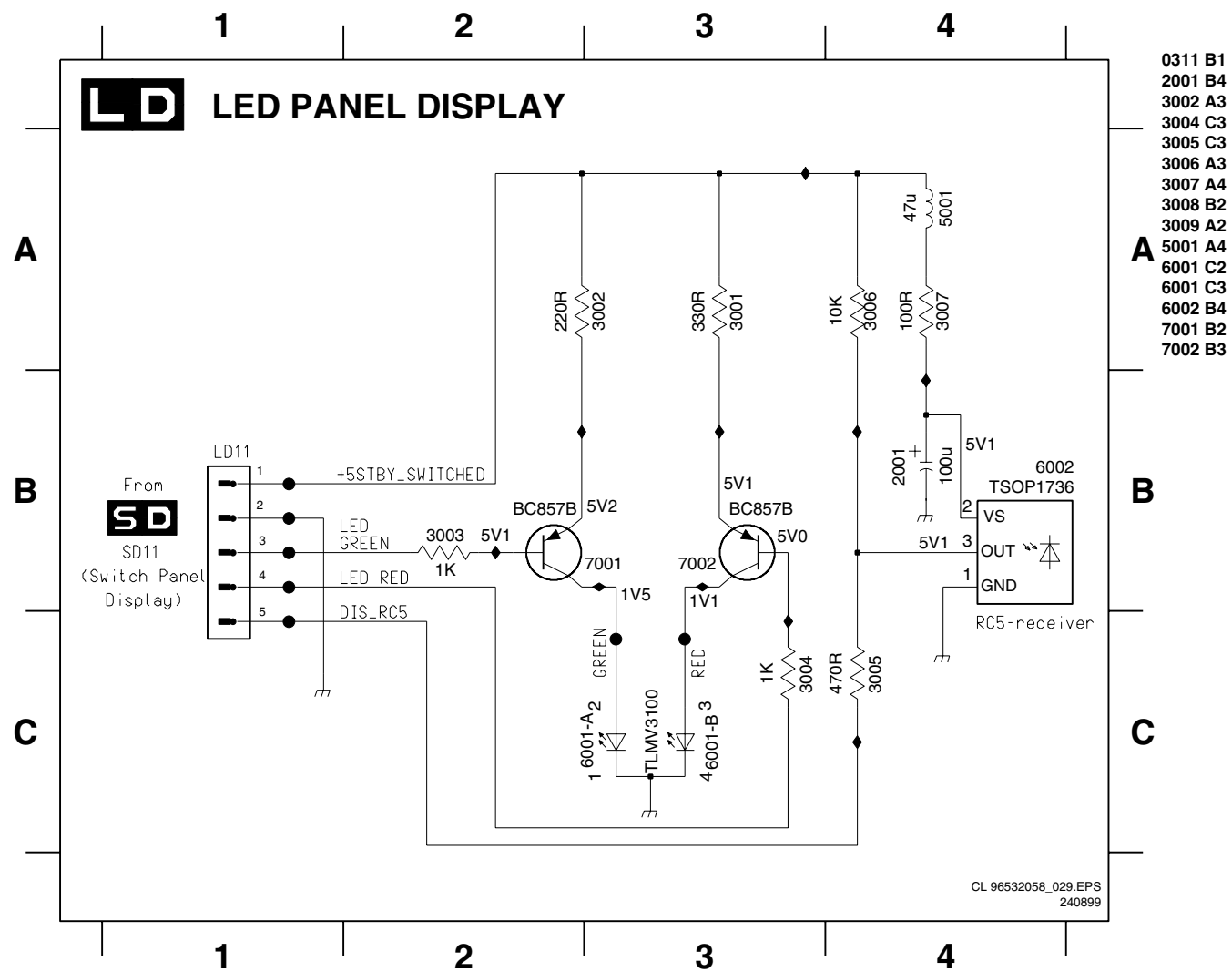

- 0311 B1
- 2001 B4
- 3002 A3
- 3004 C3
- 3005 C3
- 3006 A3
- 3007 A4
- 3008 B2
- 3009 A2
- 5001 A4
- 6001 C2
- 6001 C3
- 6002 B4
- 7001 B2
- 7002 B3

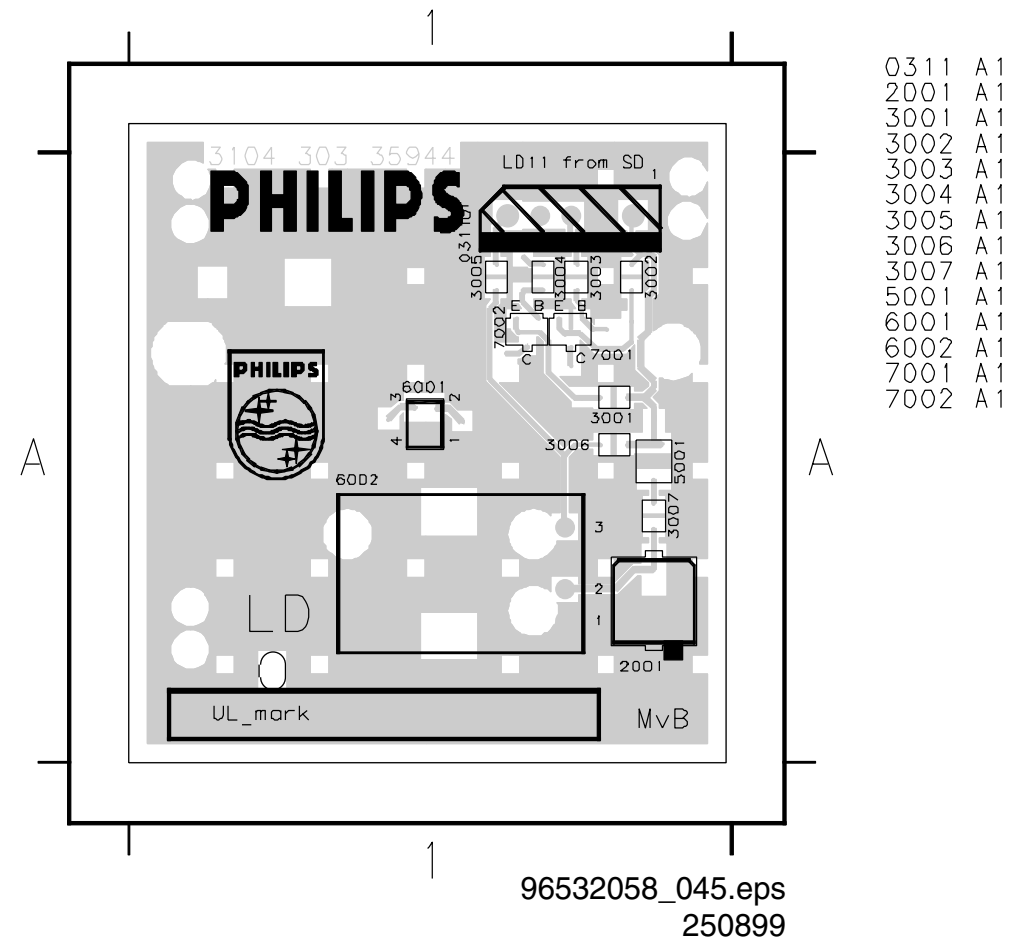

- 0311 A1
- 2001 A1
- 3001 A1
- 3002 A1
- 3003 A1
- 3004 A1
- 3005 A1
- 3006 A1
- 3007 A1
- 5001 A1
- 6001 A1
- 6002 A1
- 7001 A1
- 7002 A1

Audio amplifier A1

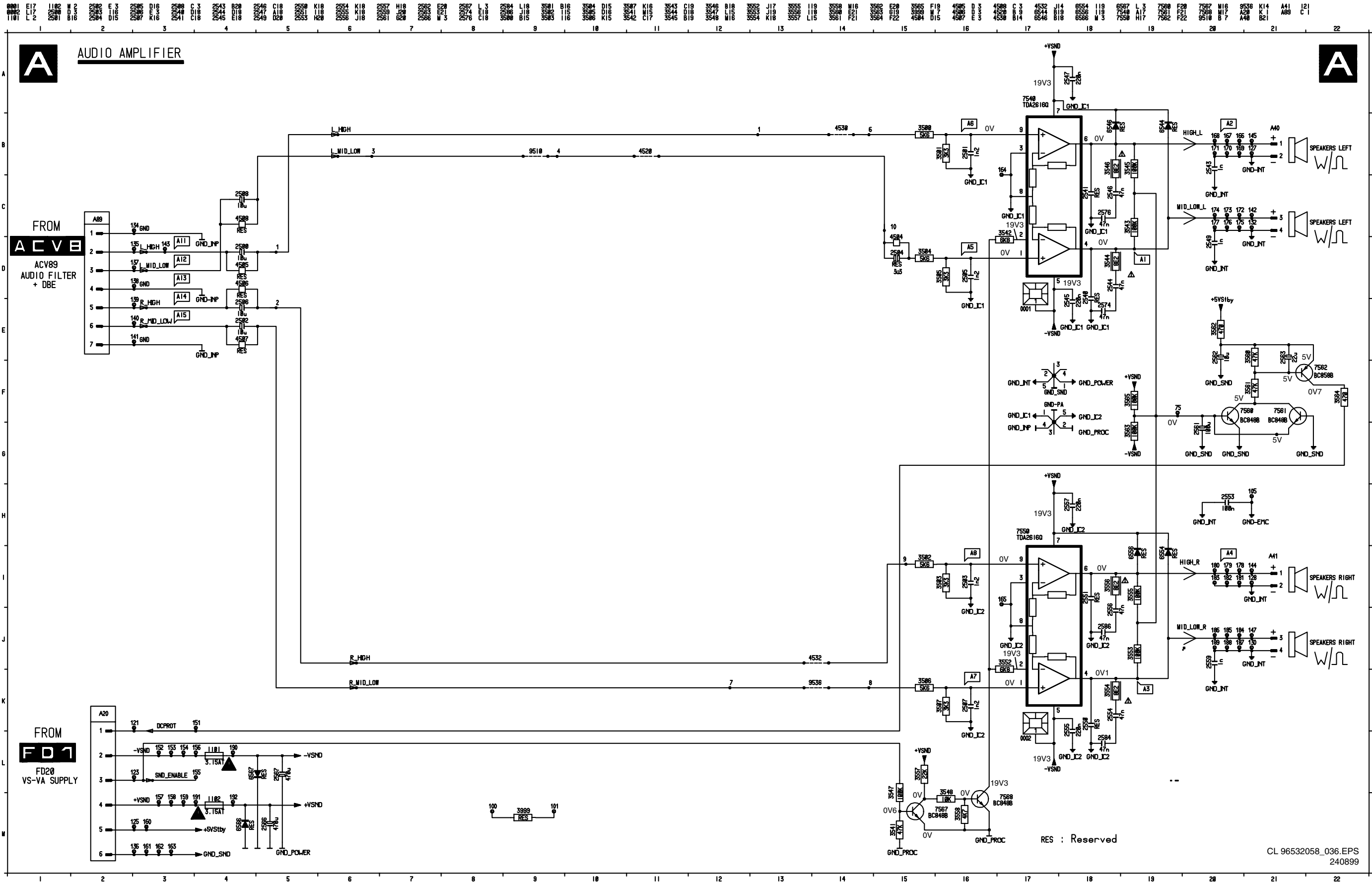

Audio amplifier A2

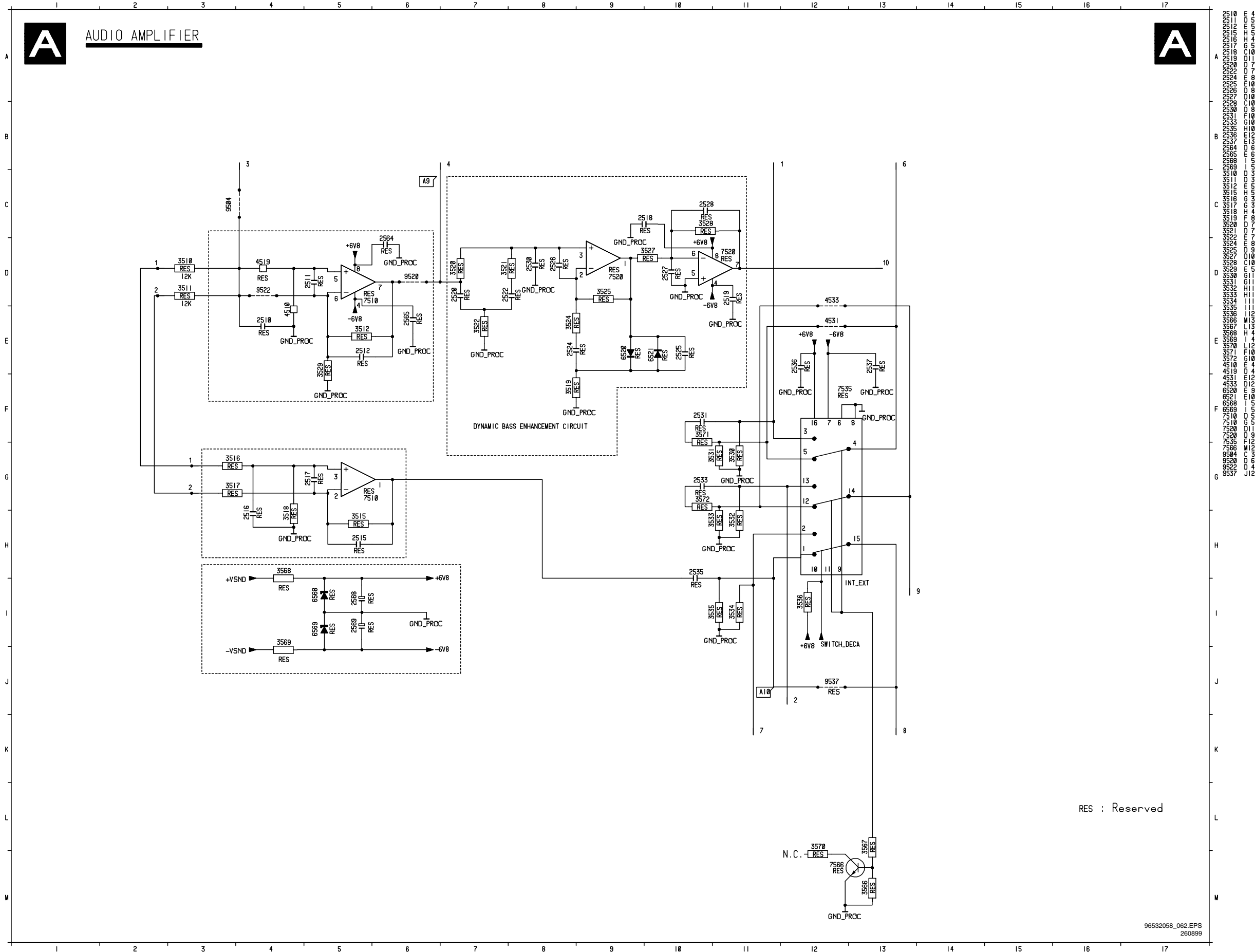

Audio amplifier (component side)

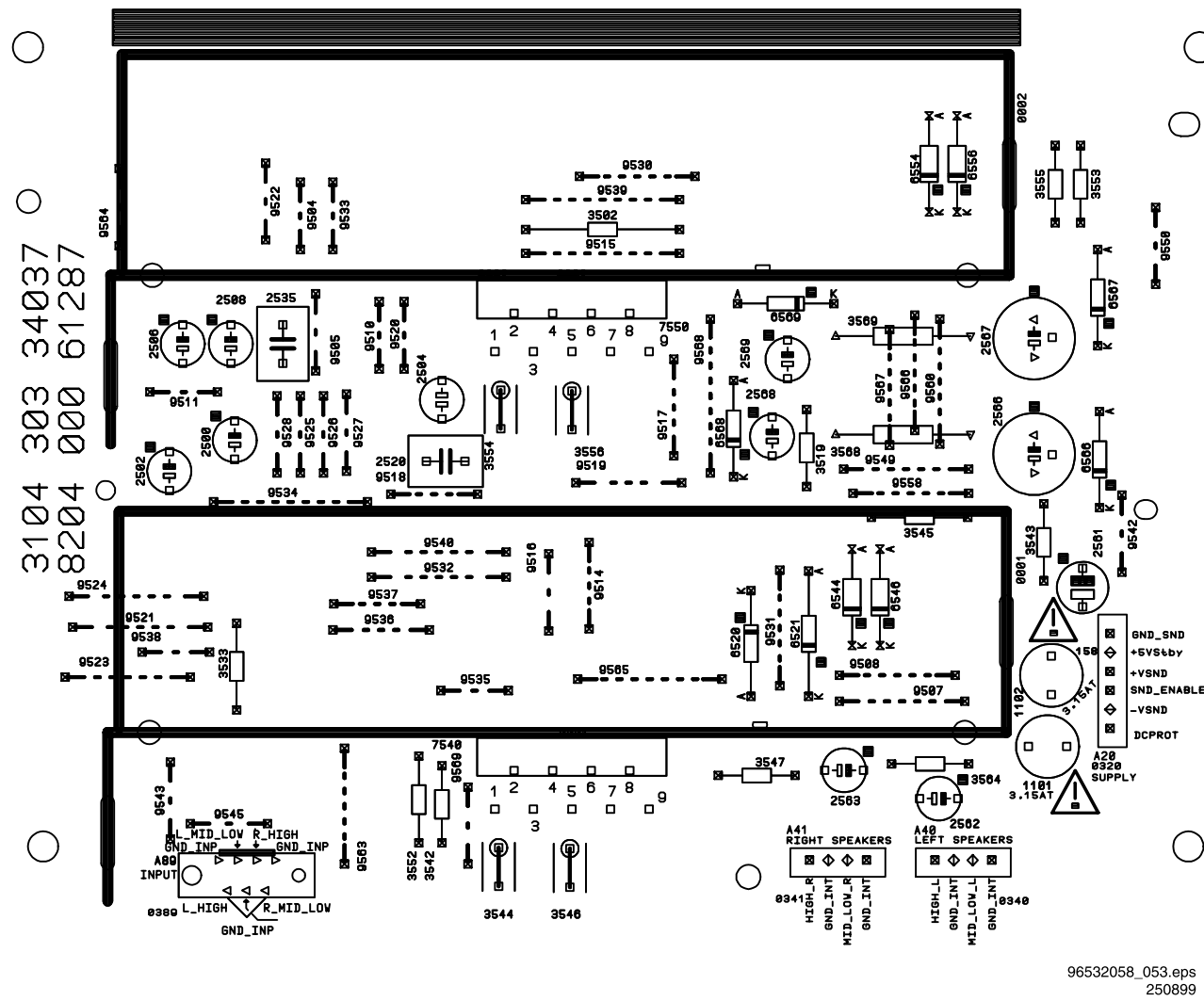

96532058_053.eps
250899

Audio amplifier (copper side)

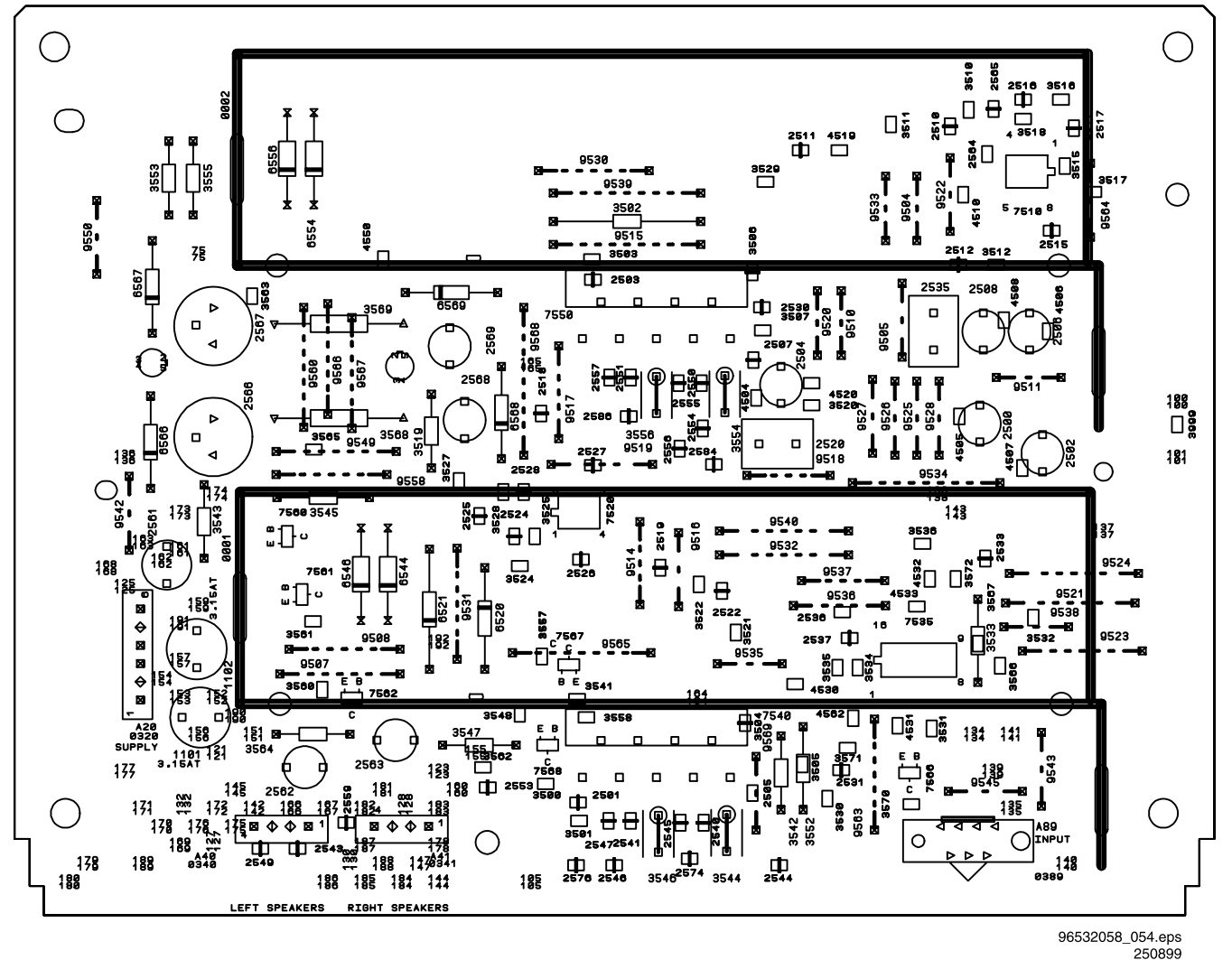

96532058_054.eps
250899

Switch panel

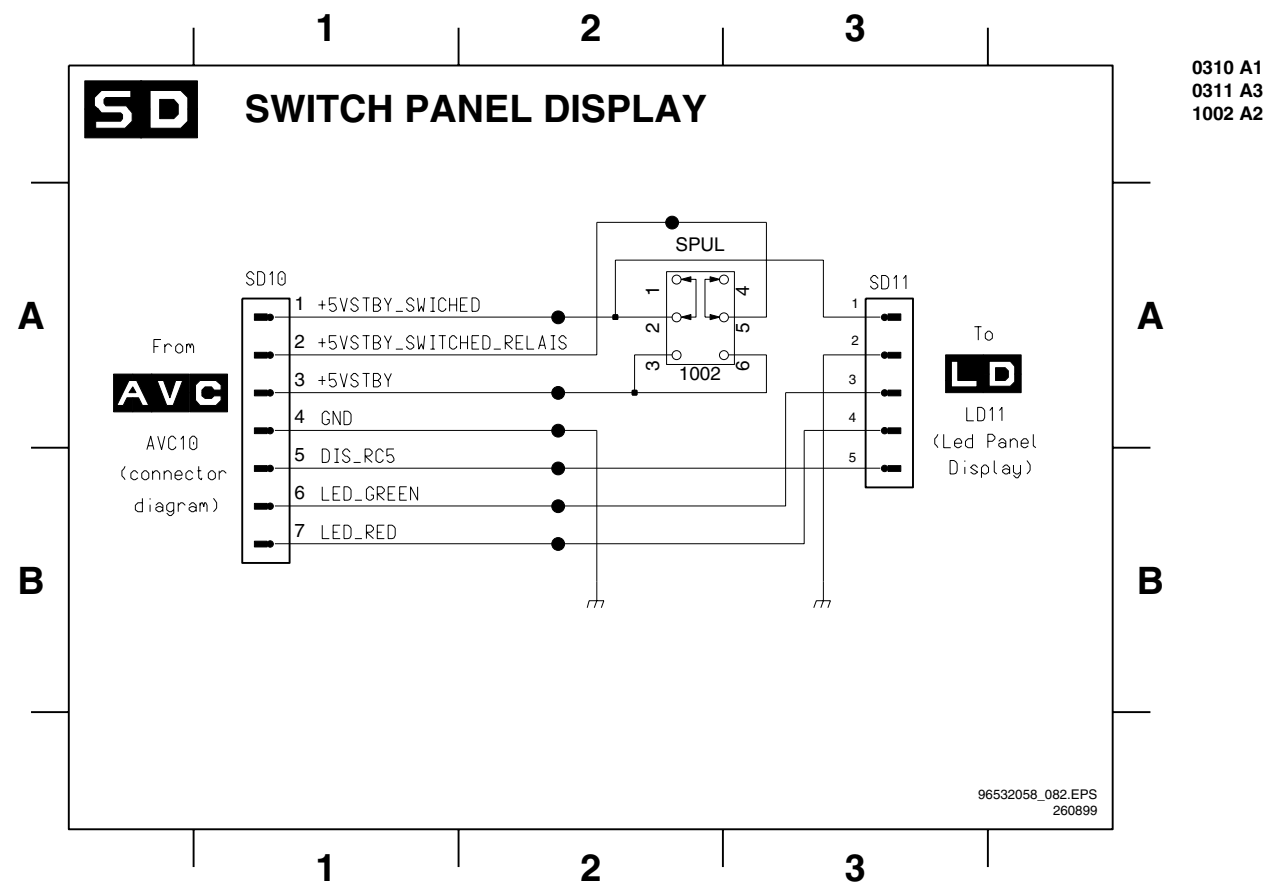

Switch panel (component side)

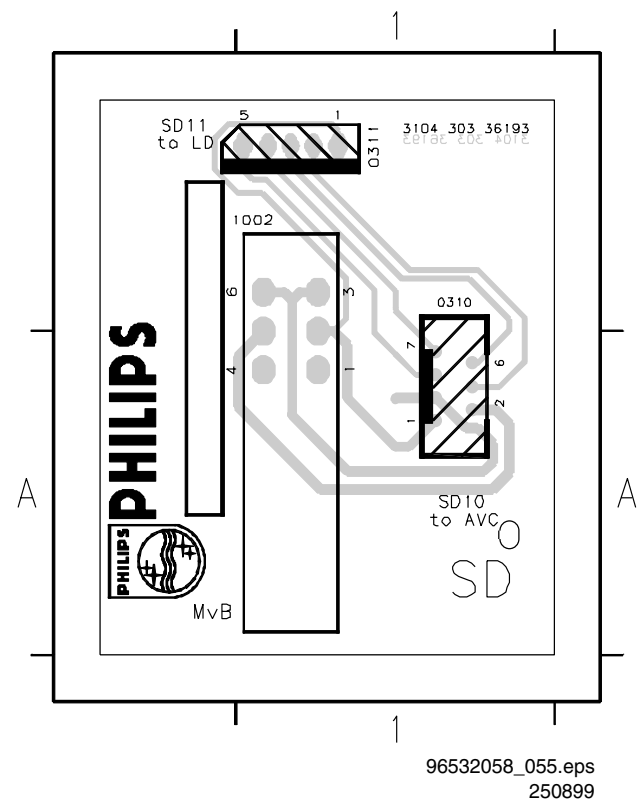

Monitor microprocessor panel

0437 D1	2003 A3	2008 C2	2013 B3	2018 E4	2023 E4	3000 D2	3006 B6	3011 C2	3017 E2	5002 A3	7003 A1
1000 C2	2004 A3	2009 D3	2014 C2	2019 E6	2024 E4	3001 D1	3007 B6	3012 B6	4001 C6	5003 A3	7004 B2
2000 A2	2005 C3	2010 B4	2015 E3	2020 E5	2025 E6	3002 C1	3008 C1	3013 B1	4002 D6	6000 D2	
2001 D2	2006 D6	2011 E6	2016 E3	2021 A1	2026 E6	3003 B4	3009 C4	3015 E2	4004 C2	7000 B8	
2002 A3	2007 C2	2012 C1	2017 E3	2022 D2	2027 C4	3004 B6	3010 C3	3016 E2	5001 A3	7001 B4	

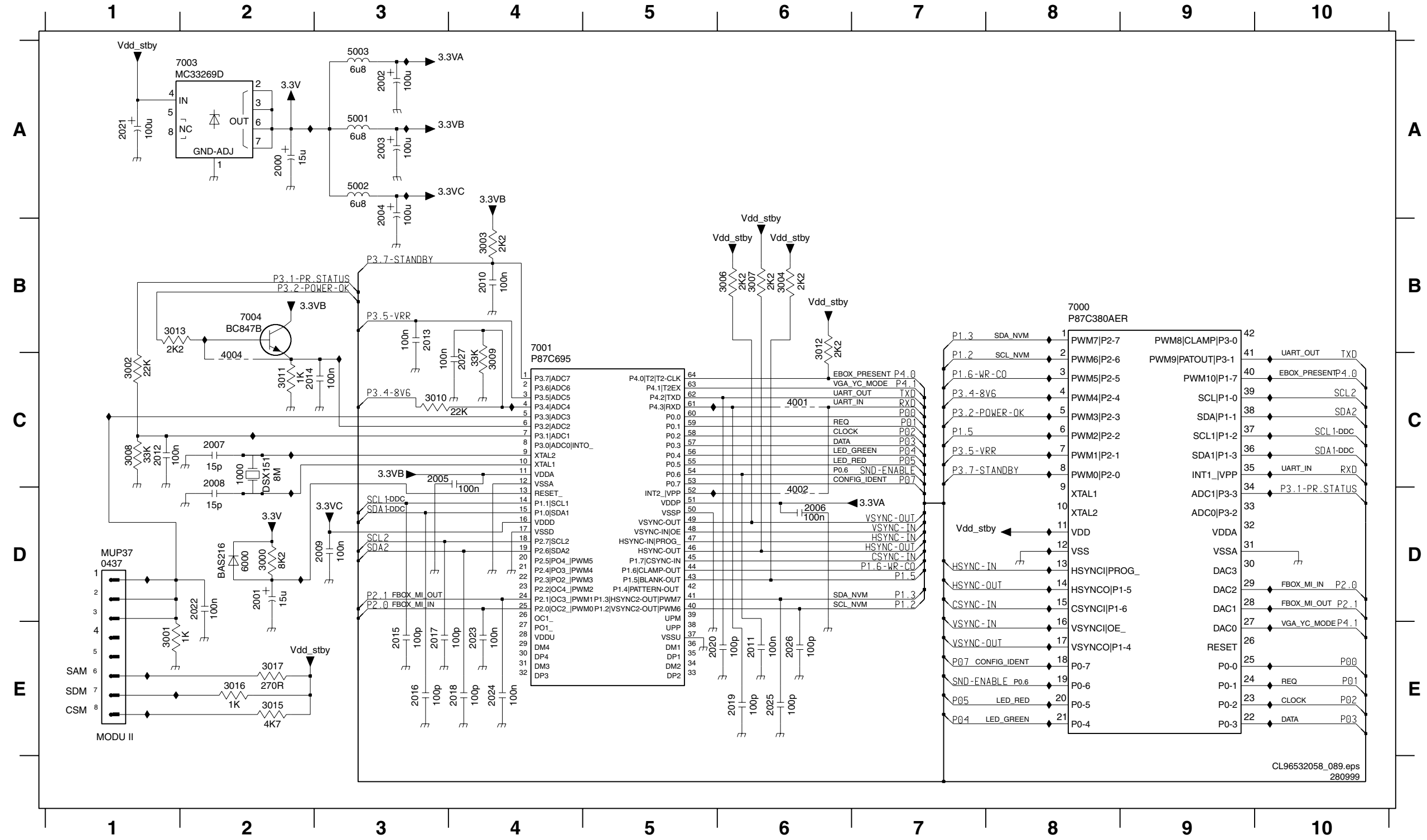

**Monitor microprocessor panel
(component side)**

0437 A2	2003 A1	5001 A1	7000 A2
1000 A1	2004 A1	5002 A1	7001 A1
2002 A1	2021 A1	5003 A1	

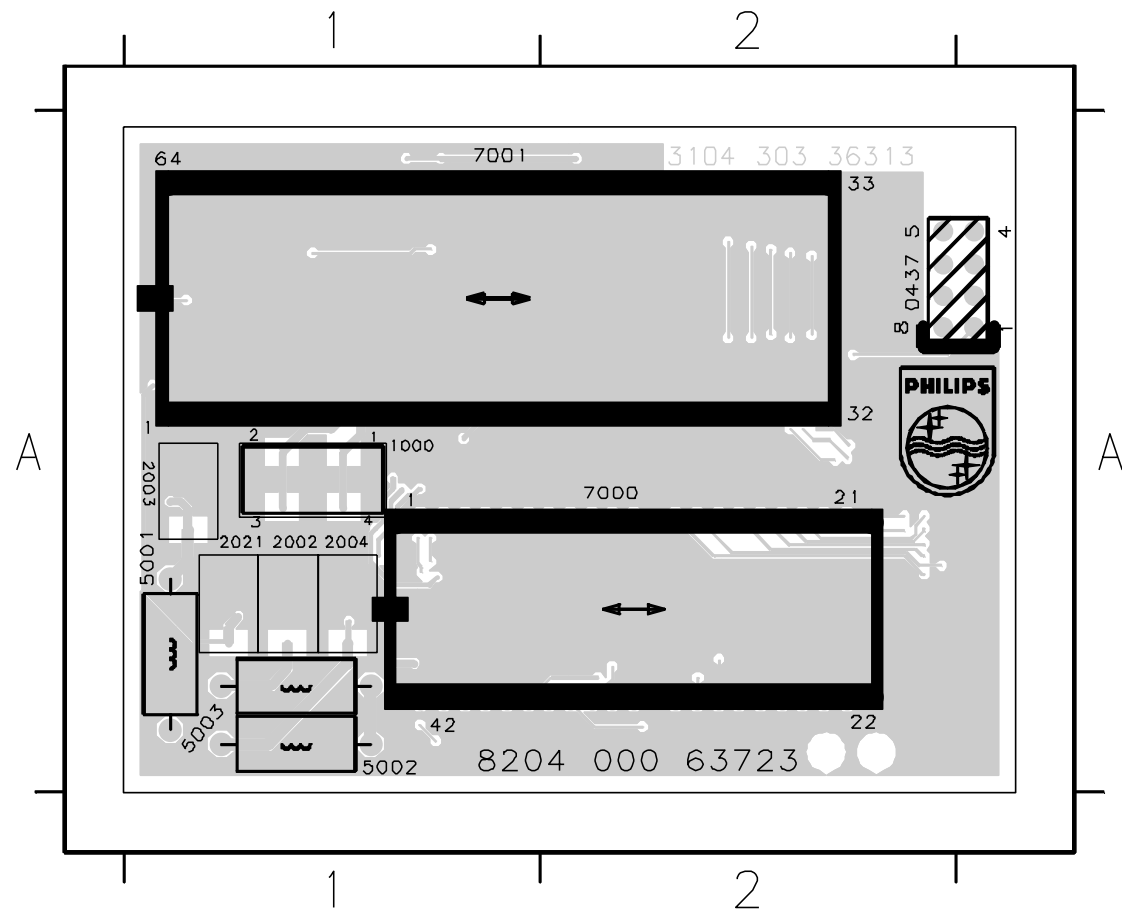

96532058_058.eps
250899

Monitor microprocessor panel (copper side)

2000 A2	2013 A2	2024 A1	3007 A1	4001 A2
2001 A2	2014 A2	2025 A1	3008 A2	4002 A2
2005 A2	2015 A1	2026 A1	3009 A2	4004 A2
2006 A2	2016 A2	2027 A2	3010 A2	6000 A2
2007 A2	2017 A1	3000 A2	3011 A2	7003 A2
2008 A2	2018 A1	3001 A2	3012 A2	7004 A2
2009 A2	2019 A2	3002 A2	3013 A2	
2010 A2	2020 A2	3003 A2	3015 A1	
2011 A2	2022 A2	3004 A1	3016 A1	
2012 A2	2023 A1	3006 A2	3017 A1	

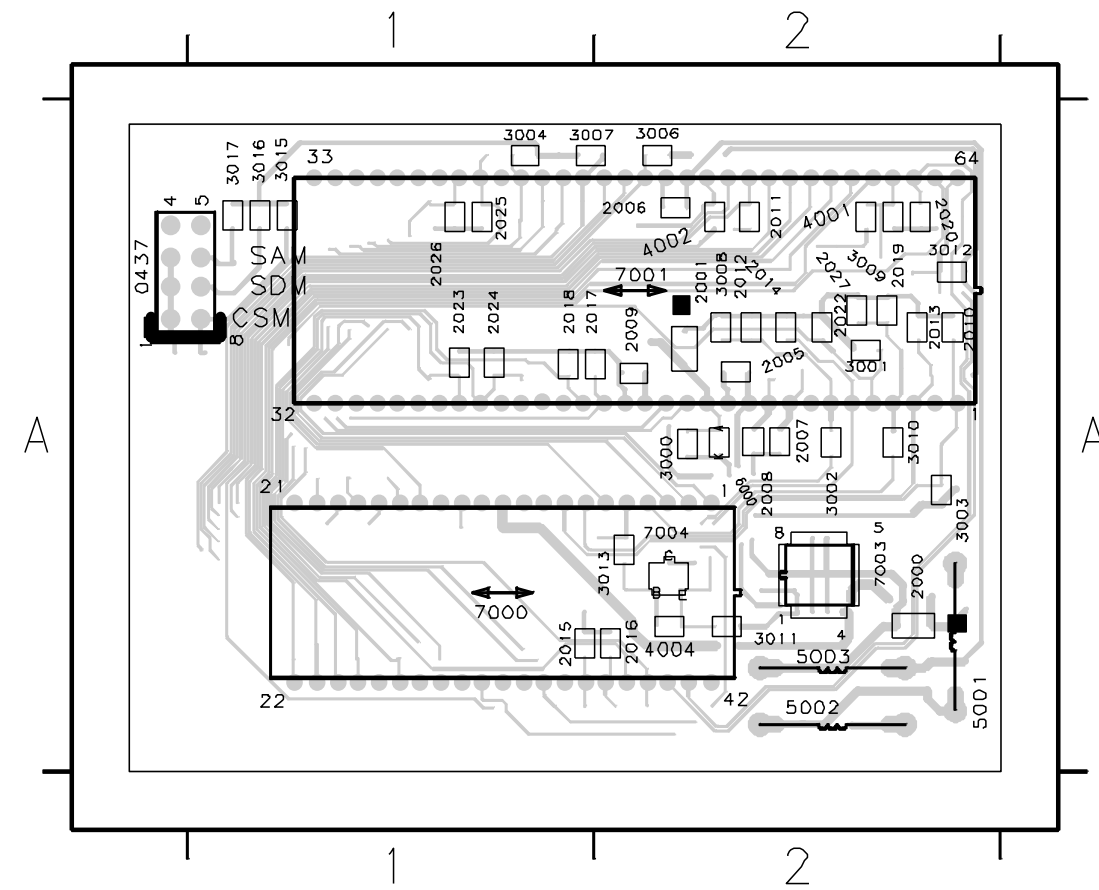

96532058_059.eps
250899

AV control

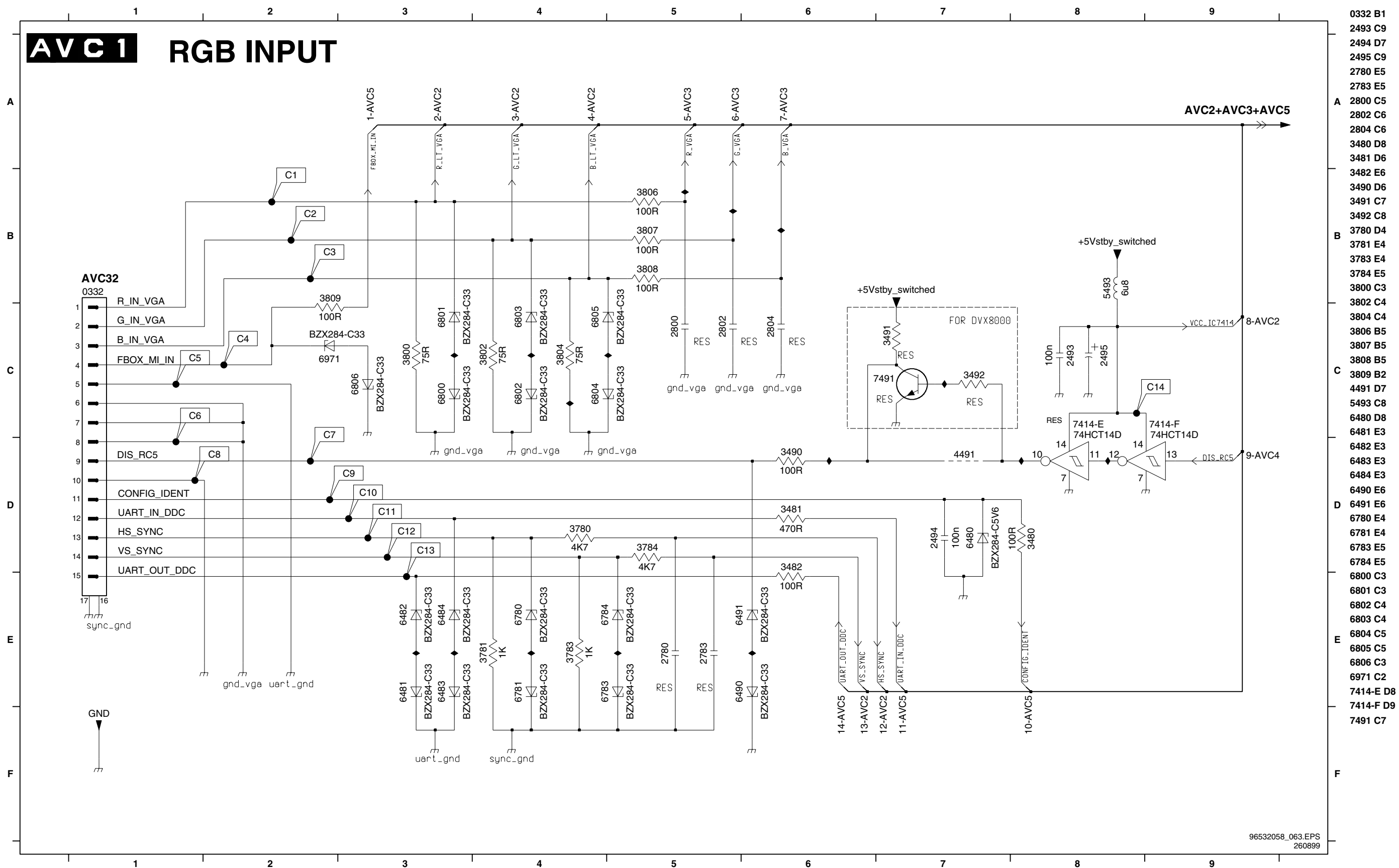

- 0332 B1
- 2493 C9
- 2494 D7
- 2495 C9
- 2780 E5
- 2783 E5
- 2800 C5
- 2802 C6
- 2804 C6
- 3480 D8
- 3481 D6
- 3482 E6
- 3490 D6
- 3491 C7
- 3492 C8
- 3780 D4
- 3781 E4
- 3783 E4
- 3784 E5
- 3800 C3
- 3802 C4
- 3804 C4
- 3806 B5
- 3807 B5
- 3808 B5
- 3809 B2
- 4491 D7
- 5493 C8
- 6480 D8
- 6481 E3
- 6482 E3
- 6483 E3
- 6484 E3
- 6490 E6
- 6491 E6
- 6780 E4
- 6781 E4
- 6783 E5
- 6784 E5
- 6800 C3
- 6801 C3
- 6802 C4
- 6803 C4
- 6804 C5
- 6805 C5
- 6806 C3
- 6971 C2
- 7414-E D8
- 7414-F D9
- 7491 C7

AV control

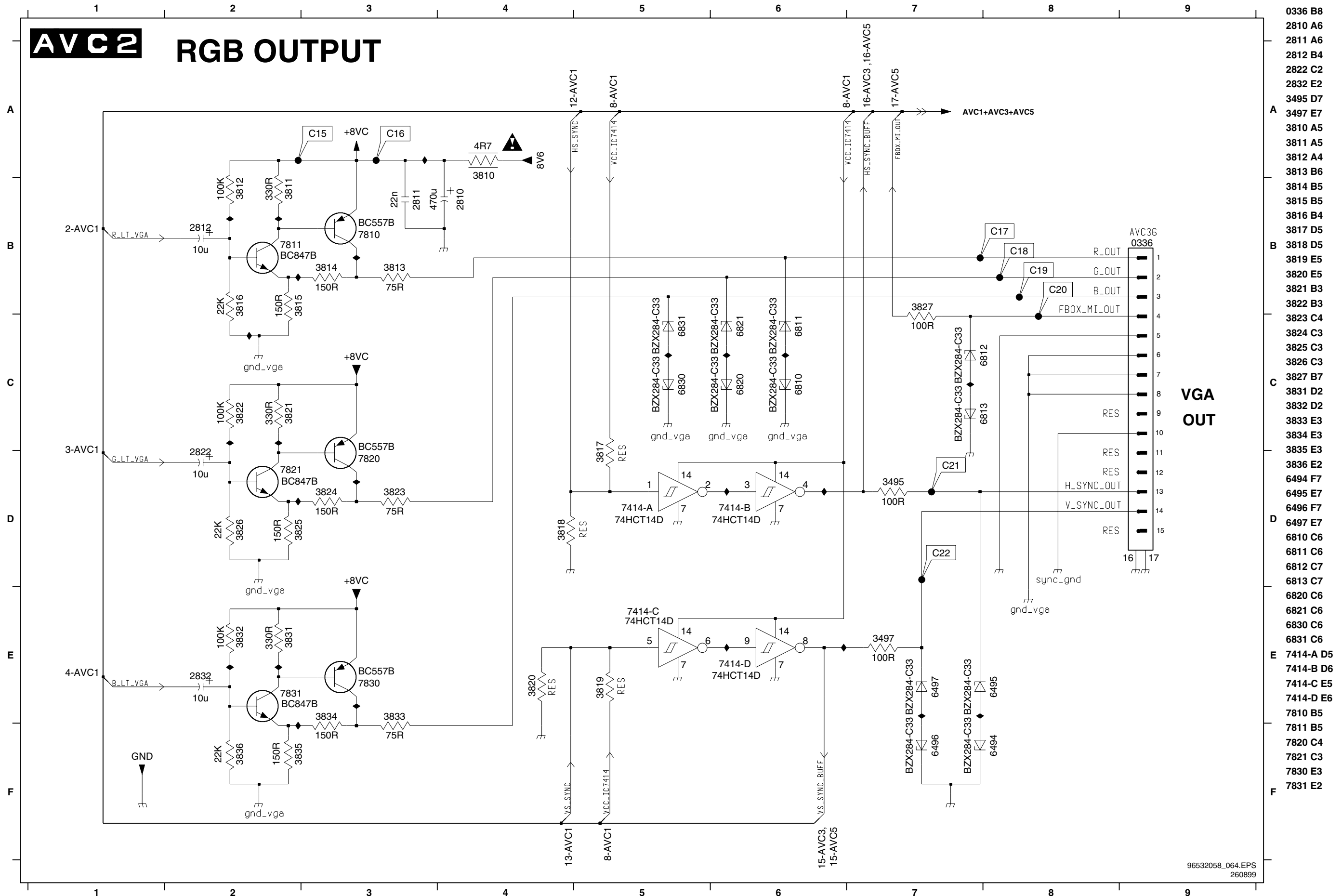

- 0336 B8
- 2810 A6
- 2811 A6
- 2812 B4
- 2822 C2
- 2832 E2
- 3495 D7
- 3497 E7
- 3810 A5
- 3811 A5
- 3812 A4
- 3813 B6
- 3814 B5
- 3815 B5
- 3816 B4
- 3817 D5
- 3818 D5
- 3819 E5
- 3820 E5
- 3821 B3
- 3822 B3
- 3823 C4
- 3824 C3
- 3825 C3
- 3826 C3
- 3827 B7
- 3831 D2
- 3832 D2
- 3833 E3
- 3834 E3
- 3835 E3
- 3836 E2
- 6494 F7
- 6495 E7
- 6496 F7
- 6497 E7
- 6810 C6
- 6811 C6
- 6812 C7
- 6813 C7
- 6820 C6
- 6821 C6
- 6830 C6
- 6831 C6
- 7414-A D5
- 7414-B D6
- 7414-C E5
- 7414-D E6
- 7810 B5
- 7811 B5
- 7820 C4
- 7821 C3
- 7830 E3
- 7831 E2

VGA OUT

AV control

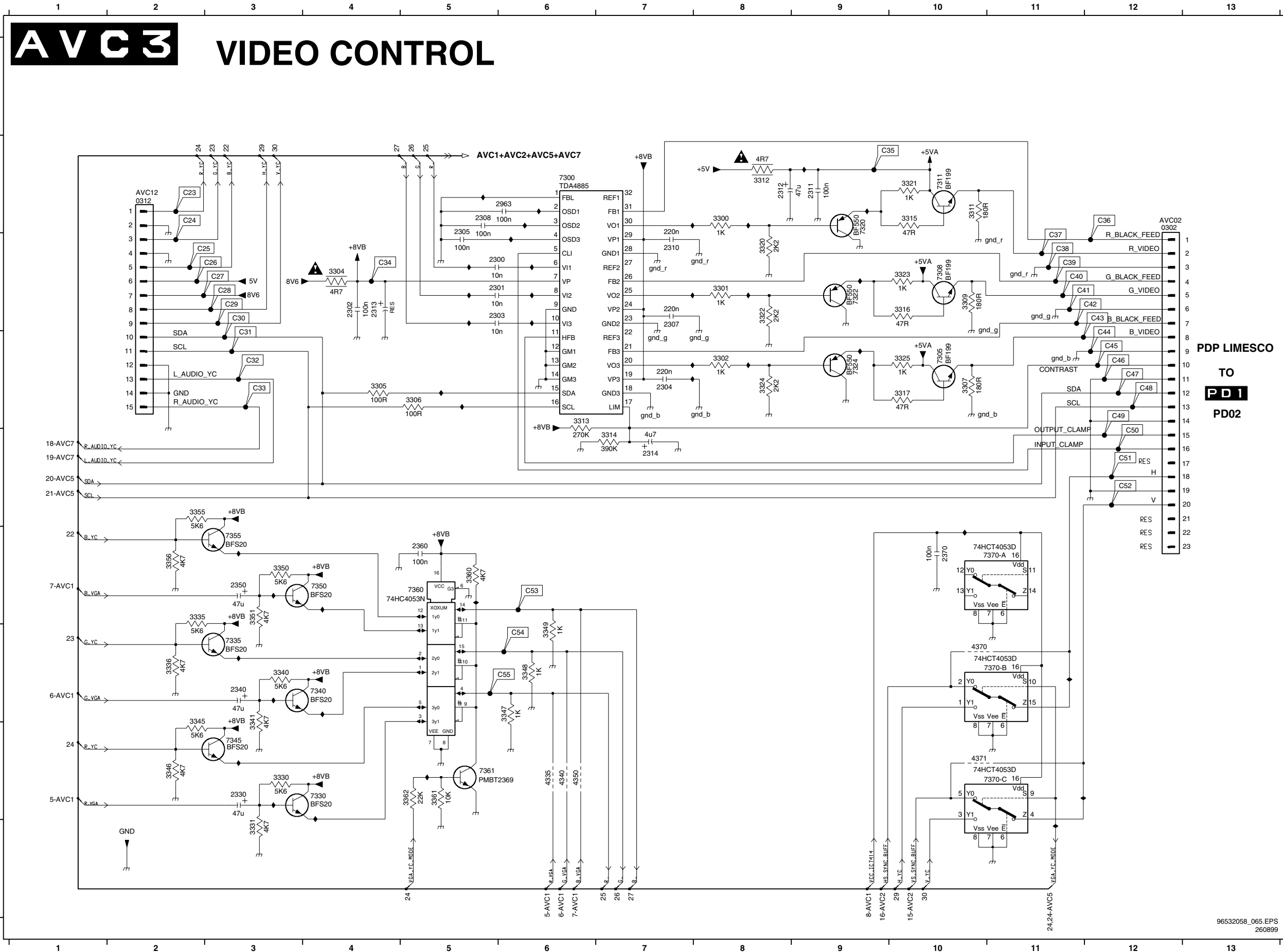

- 0302 B12
- 0312 B2
- 2300 B5
- 2301 C5
- 2302 C4
- 2303 C5
- A 2304 E7
- 2305 B5
- 2307 D8
- 2308 B5
- 2310 B8
- 2311 A10
- 2312 A10
- 2313 C5
- B 2314 D7
- 2330 H3
- 2340 F3
- 2350 E3
- 2360 E5
- 2370 G10
- 2963 B5
- C 3300 B8
- 3301 C7
- 3302 E8
- 3304 B4
- 3305 D5
- 3306 D5
- 3307 E10
- 3309 D10
- D 3311 B10
- 3312 A11
- 3313 D6
- 3314 D7
- 3315 B9
- 3316 C9
- 3317 D9
- 3320 B8
- E 3321 A9
- 3322 D8
- 3323 C9
- 3324 E8
- 3325 D9
- 3330 G4
- 3331 H4
- 3335 G3
- F 3336 G3
- 3340 F4
- 3341 G4
- 3345 H3
- 3346 H3
- 3347 G6
- 3348 F6
- G 3349 F6
- 3350 E4
- 3351 E4
- 3355 E3
- 3356 F3
- 3360 F6
- 3361 I5
- 3362 H5
- H 4335 E6
- 4340 E6
- 4350 E6
- 4370 G9
- 4371 I9
- I 7300 B6
- 7305 D10
- 7308 C10
- 7311 B10
- 7320 B8
- 7322 C8
- 7324 D8
- 7330 H4
- 7335 G3

PDP LIMESCO
TO
PDI
PD02

AV control

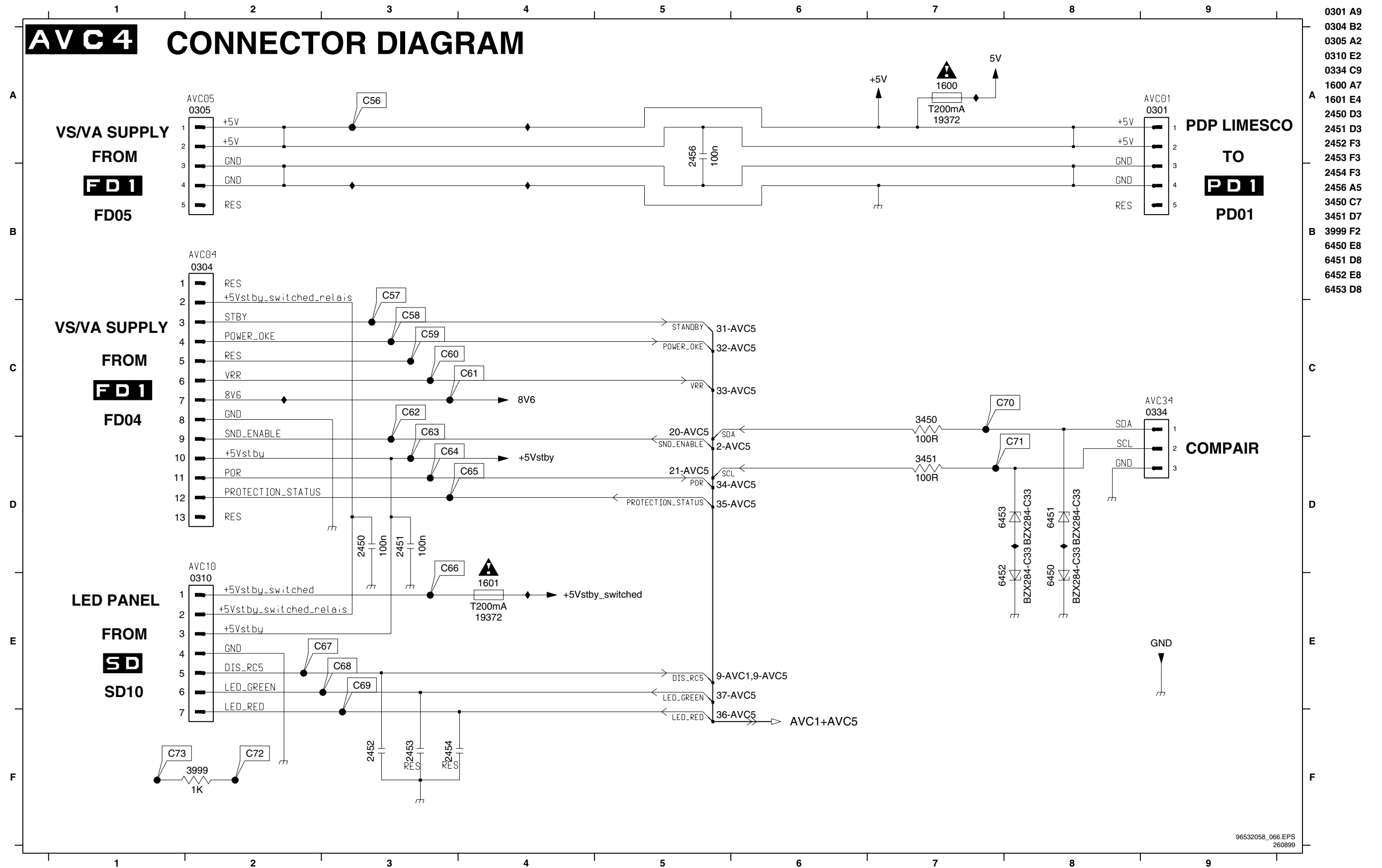

AV control

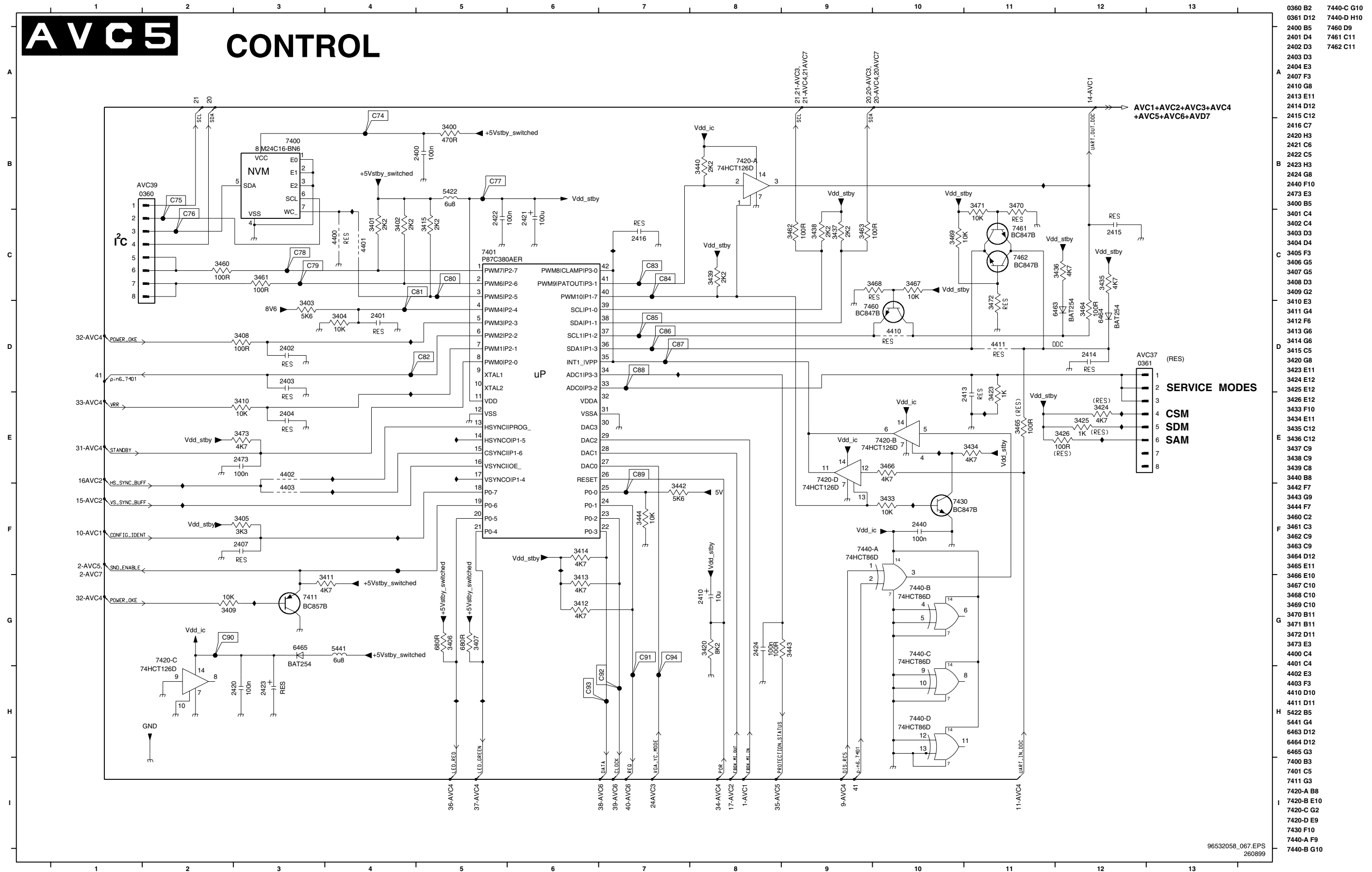

- 0360 B2 7440-C G10
- 0361 D12 7440-D H10
- 2400 B5 7460 D9
- 2401 D4 7461 C11
- 2402 D3 7462 C11
- 2403 D3
- 2404 E3
- 2407 F3
- 2410 G8
- 2413 E11
- 2414 D12
- 2415 C12
- 2416 C7
- 2420 H3
- 2421 C6
- 2422 C5
- 2423 H3
- 2424 G8
- 2440 F10
- 2473 E3
- 3400 B5
- 3401 C4
- 3402 C4
- 3403 D3
- 3404 D4
- 3405 F3
- 3406 G5
- 3407 G5
- 3408 D3
- 3409 G2
- 3410 E3
- 3411 G4
- 3412 F6
- 3413 G6
- 3414 G6
- 3415 C5
- 3420 G8
- 3423 E11
- 3424 E12
- 3425 E12
- 3426 E12
- 3433 F10
- 3434 E11
- 3435 C12
- 3436 C12
- 3437 C9
- 3438 C9
- 3439 C8
- 3440 B8
- 3442 F7
- 3443 G9
- 3444 F7
- 3460 C2
- 3461 C3
- 3462 C9
- 3463 C9
- 3464 D12
- 3465 E11
- 3466 E10
- 3467 C10
- 3468 C10
- 3469 C10
- 3470 B11
- 3471 B11
- 3472 D11
- 3473 E3
- 4400 C4
- 4401 C4
- 4402 E3
- 4403 F3
- 4410 D10
- 4411 D11
- 5422 B5
- 5441 G4
- 6463 D12
- 6464 D12
- 6465 G3
- 7400 B3
- 7401 C5
- 7411 G3
- 7420-A B8
- 7420-B E10
- 7420-C G2
- 7420-D E9
- 7430 F10
- 7440-A F9
- 7440-B G10

AV control

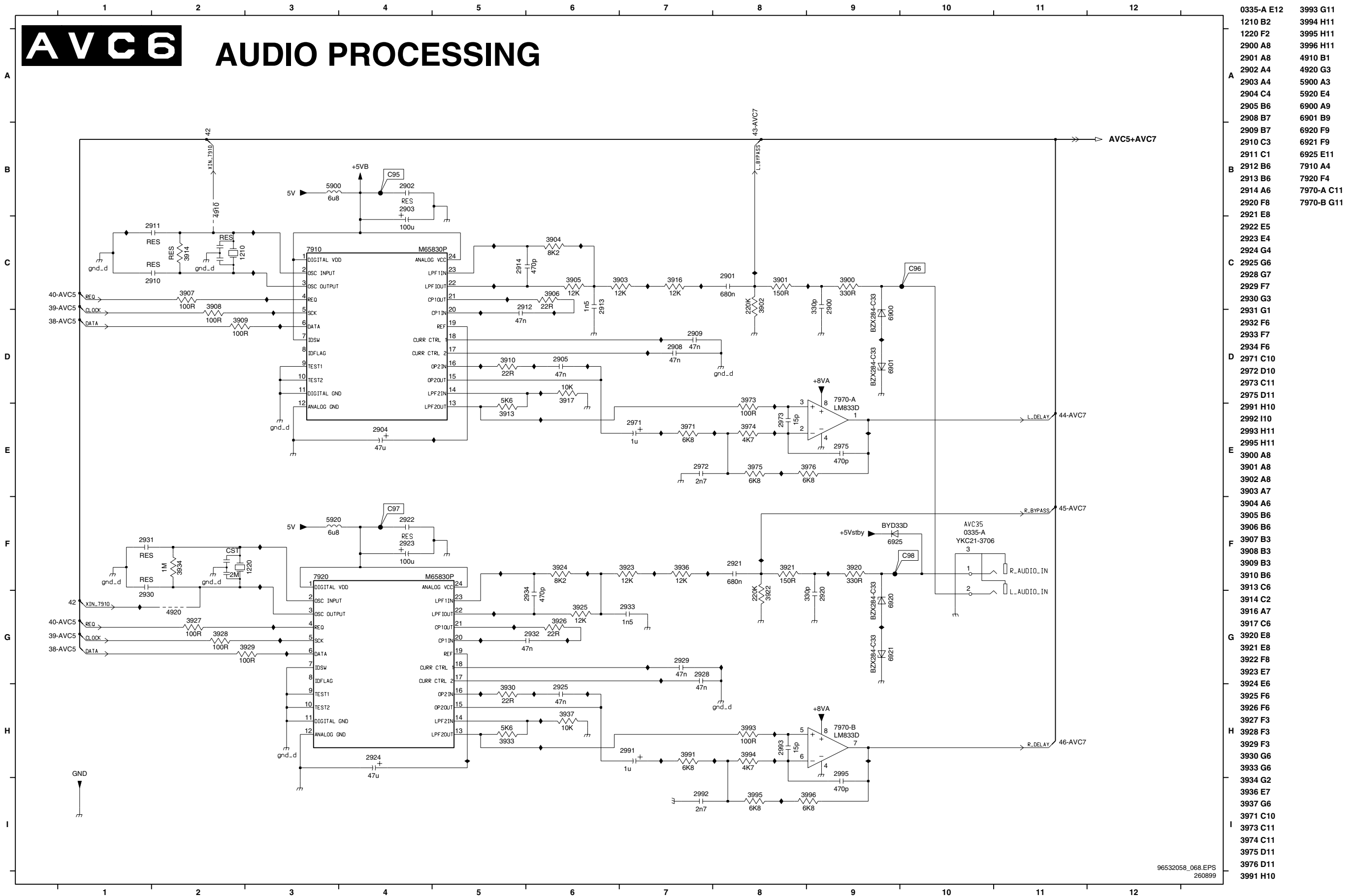

AV control

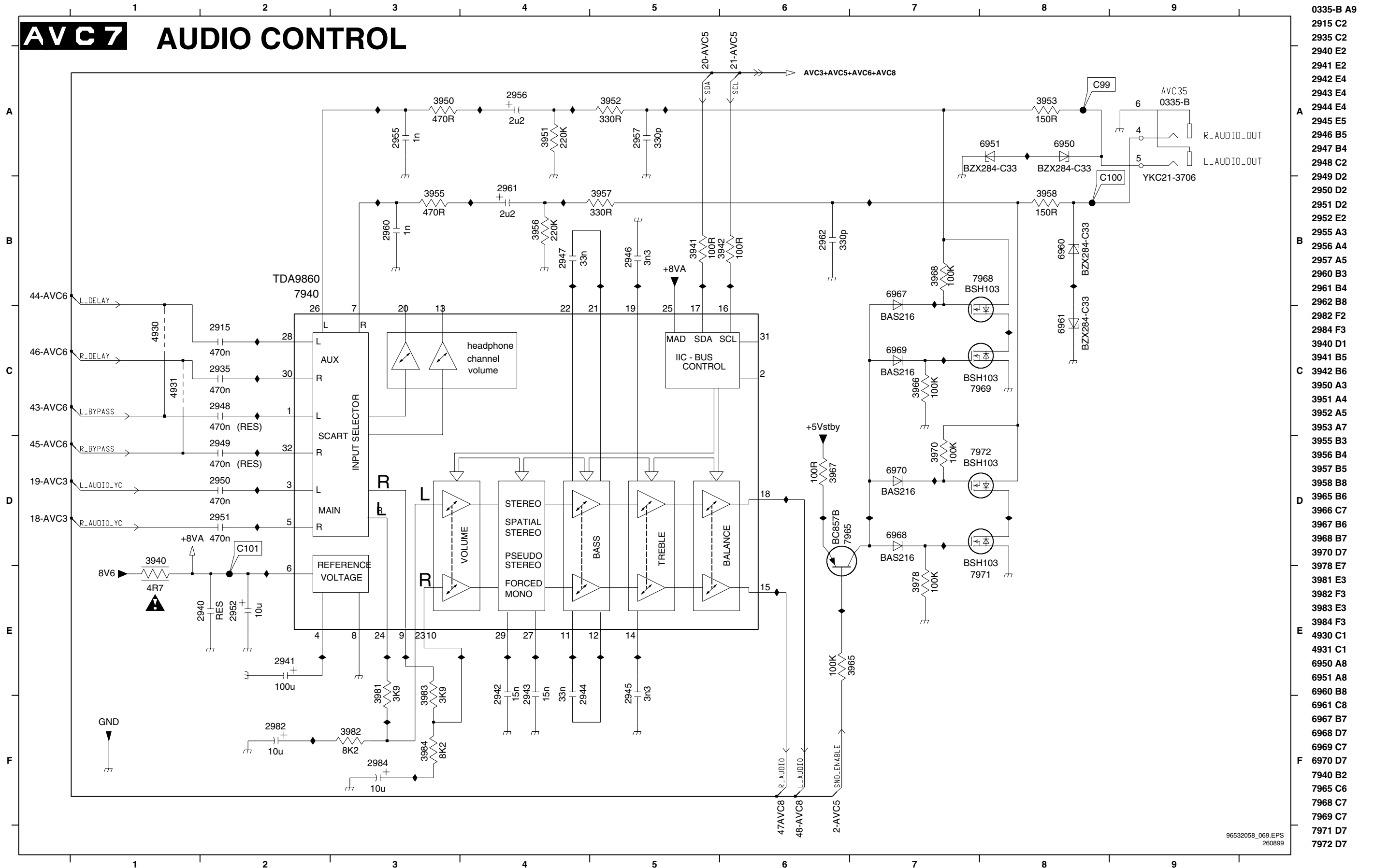

0335-B A9
2915 C2
2935 C2
2940 E2
2941 E2
2942 E4
2943 E4
2944 E4
2945 E5
2946 B5
2947 B4
2948 C2
2949 D2
2950 D2
2951 D2
2952 E2
2955 A3
2956 A4
2957 A5
2960 B3
2961 B4
2962 B8
2982 F2
2984 F3
3940 D1
3941 B5
3942 B6
3950 A3
3951 A4
3952 A5
3953 A7
3955 B3
3956 B4
3957 B5
3958 B8
3965 B6
3966 C7
3967 B6
3968 B7
3970 D7
3978 E7
3981 E3
3982 F3
3983 E3
3984 F3
4930 C1
4931 C1
6950 A8
6951 A8
6960 B8
6961 C8
6967 B7
6968 D7
6969 C7
6970 D7
7940 B2
7965 C6
7968 C7
7969 C7
7971 D7
7972 D7

AV control

AVC8 AUDIO FILTER + DBE

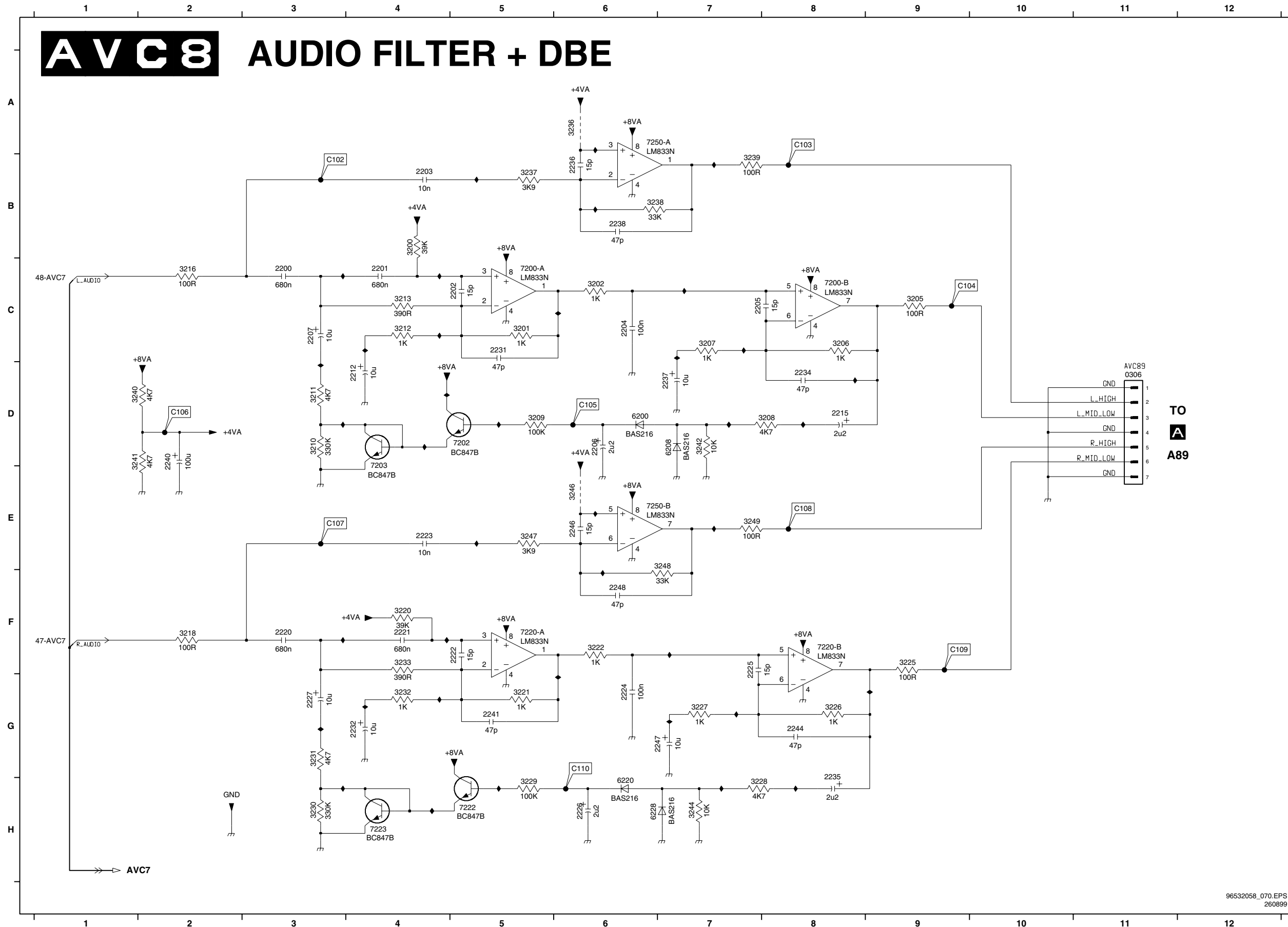

0306 D11	3248 E7
2200 C3	3249 E7
2201 C4	6200 D6
2202 C5	6208 D7
2203 B4	6220 H6
2204 C6	6228 H6
2205 C7	7200-A C5
2206 D6	7200-B C8
2207 C3	7202 D5
2212 D4	7203 E4
2215 D8	7220-A F5
2220 F3	7220-B F8
2221 F4	7222 H5
2222 F5	7223 H4
2223 E4	7250-A A6
2224 G6	7250-B E6
2225 F7	
2226 H6	
2227 G3	
2231 C5	
2232 G4	
2234 D8	
2235 H8	
2236 B6	
2237 D7	
2238 B6	
2240 D2	
2241 G5	
2244 G8	
2246 E6	
2247 G7	
2248 F6	
3200 B4	
3201 C5	
3202 C6	
3205 C9	
3206 C8	
3207 C7	
3208 D8	
3209 D5	
3210 D3	
3211 D3	
3212 C4	
3213 C4	
3216 C2	
3218 F2	
3220 F4	
3221 G5	
3222 F6	
3225 F9	
3226 G8	
3227 G7	
3228 H7	
3229 H5	
3230 H3	
3231 G3	
3232 G4	
3233 F4	
3236 A6	
3237 B5	
3238 B6	
3239 B7	
3240 D1	
3241 D1	
3242 D7	
3244 H7	
3246 E6	
3247 E5	

TO
A
A89

AV control (component side)

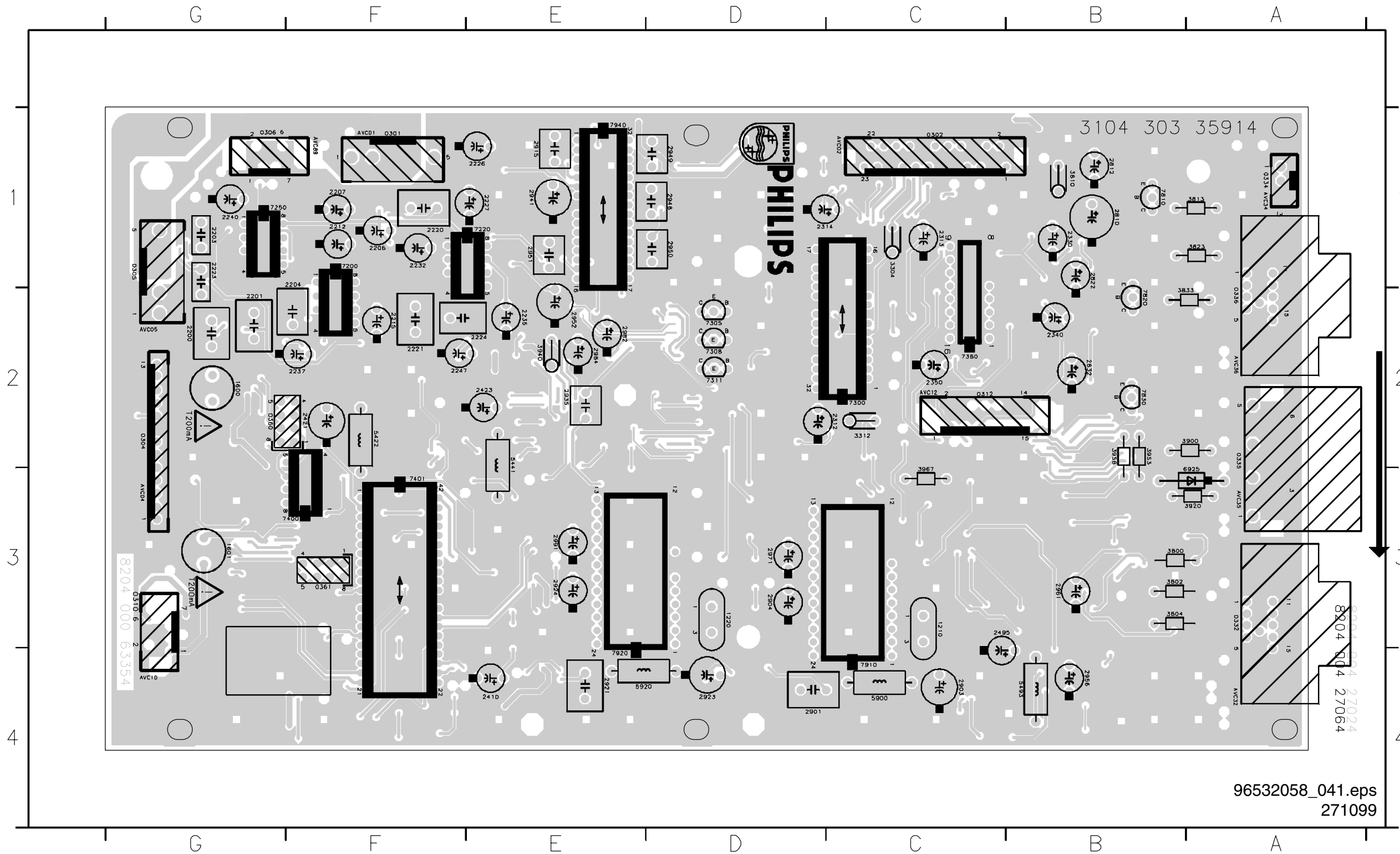

0301	F1	3804	B3
0302	C1	3810	B1
0304	G2	3813	A1
0305	G1	3823	A1
0306	G1	3833	A2
0310	G3	3900	A2
0312	C2	3920	A3
0332	A3	3940	E2
0334	A1	3953	B2
0335	A2	3958	B2
0336	A2	3967	C3
0360	G2	5422	F2
0361	F3	5441	E2
1210	C3	5493	B4
1220	D3	5900	C4
1600	G2	5920	E4
1601	G3	6925	A3
2200	G2	7200	F1
2201	G2	7220	E1
2203	G1	7250	G1
2204	F1	7300	C2
2206	F1	7305	D2
2207	F1	7308	D2
2212	F1	7311	D2
2215	F2	7360	C2
2220	F1	7400	F3
2221	F2	7401	F3
2223	G1	7810	B1
2224	E2	7820	B2
2226	E1	7830	B2
2227	E1	7910	C4
2232	F1	7920	E4
2235	E2	7940	E1
2237	F2		
2240	G1		
2247	F2		
2312	C2		
2313	C1		
2314	D1		
2330	B1		
2340	B2		
2350	C2		
2410	F4		
2421	F2		
2423	E2		
2495	C3		
2810	B1		
2812	B1		
2822	B1		
2832	B2		
2901	D4		
2903	C4		
2904	D3		
2915	F1		
2921	F4		
2923	D4		
2924	F3		
2935	E2		
2941	E1		
2948	D1		
2949	D1		
2950	D1		
2951	E1		
2952	E2		
2956	B4		
2961	B3		
2971	D3		
2982	E2		
2984	E2		
2991	E3		
3304	C1		
3312	C2		
3800	B3		
3802	B3		

96532058_041.eps
271099

AV control (copper side)

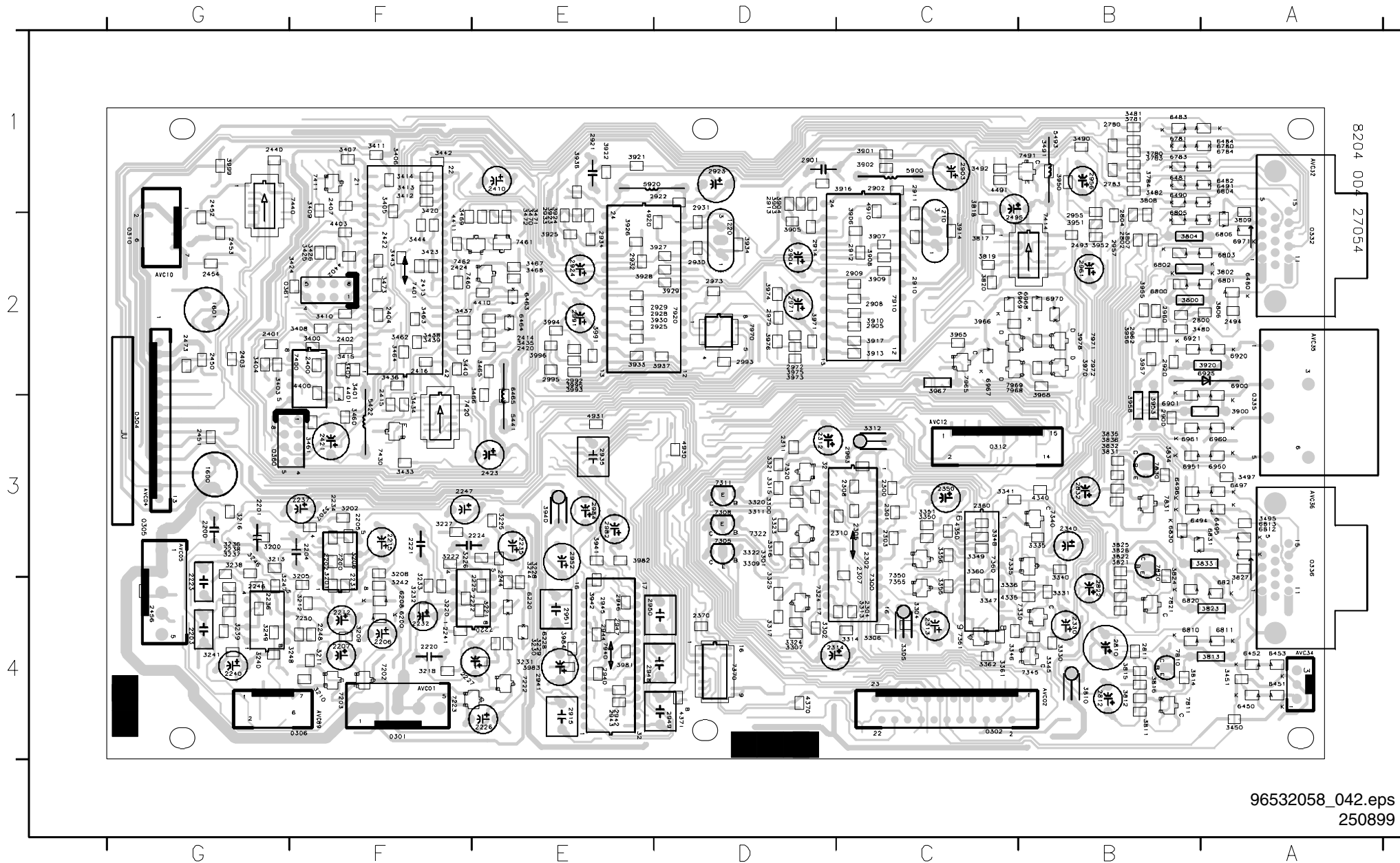

2202	F3	2942	F4	3330	B4	3780	B1	3981	F4	6961	B3
2205	F3	2943	F4	3331	B4	3781	B1	3982	F3	6967	C2
2222	F4	2944	F4	3335	B3	3783	B1	3983	F3	6968	B2
2225	F4	2945	F4	3336	B3	3784	B1	3984	F4	6969	B2
2231	F4	2946	F4	3340	B4	3806	A2	3991	F2	6970	B2
2234	F3	2947	F4	3341	C3	3807	B2	3993	F2	6971	A2
2236	F4	2955	B2	3345	B4	3808	B1	3994	F2	7202	F4
2238	F3	2957	B2	3346	C4	3809	A2	3995	F2	7203	F4
2241	F4	2960	B2	3347	C4	3811	B4	3996	F2	7222	F4
2244	F4	2962	B2	3348	C3	3812	B4	3999	G1	7223	F4
2246	F4	2963	C3	3349	C3	3814	B4	4335	C4	7320	D3
2248	F4	2972	D2	3350	C3	3815	B4	4340	B3	7322	D3
2300	C3	2973	D2	3351	C3	3816	B4	4350	C3	7324	D4
2301	C3	2975	D2	3355	C4	3817	C2	4370	D4	7330	B4
2302	C3	2992	D2	3356	C3	3818	C1	4371	D4	7335	C3
2303	C3	2993	D2	3360	C3	3819	C2	4400	F2	7340	B3
2304	C4	2995	D2	3361	C4	3820	C2	4401	F2	7345	B4
2305	C3	3200	F1	3362	C4	3821	B3	4402	F2	7346	B4
2307	C3	3201	F1	3400	F2	3824	B3	4403	F2	7350	C3
2308	C3	3202	F1	3401	F2	3825	B3	4410	F2	7355	C4
2310	D3	3206	F3	3402	F2	3825	B3	4411	F2	7370	D4
2311	D3	3208	F3	3403	G2	3826	B3	4411	C1	7411	F1
2360	C3	3207	F3	3404	G2	3827	A4	4910	C1	7414	B2
2370	F4	3208	F3	3405	F1	3831	B3	4920	E2	7420	F3
2400	F2	3209	F4	3406	F1	3832	B3	4930	D3	7430	F3
2401	G2	3210	F4	3407	F1	3834	B3	4931	C3	7440	F1
2402	F2	3211	F4	3408	F2	3835	B3	6200	F4	7460	F2
2403	F2	3212	F4	3409	F1	3836	B3	6208	F4	7461	E2
2404	F2	3213	G3	3410	F2	3901	C1	6220	E4	7462	F2
2407	F1	3216	G3	3411	F1	3902	C1	6228	E4	7491	B1
2413	F2	3218	F4	3412	F1	3903	D1	6450	A4	7811	B4
2414	F2	3220	F4	3413	F1	3904	D1	6451	A4	7821	B4
2415	F2	3221	F4	3414	F1	3905	D2	6452	A4	7831	B3
2416	F2	3222	F4	3415	F1	3906	D2	6453	A4	7965	C2
2420	F2	3225	F4	3420	F1	3907	C2	6463	E2	7966	C2
2422	F2	3228	F3	3423	F2	3908	C2	6464	E2	7969	C2
2424	F2	3227	F3	3424	F2	3909	C2	6465	E3	7970	D2
2440	C1	3228	F4	3425	F2	3910	C2	6480	A2	7971	B2
2450	C1	3229	F4	3426	F2	3913	C2	6481	B1	7972	B2
2451	C3	3230	F4	3433	F3	3914	C2	6482	A1		
2452	C1	3231	F4	3434	F3	3916	C1	6483	B1		
2453	C2	3232	F4	3435	F2	3917	C2	6484	A1		
2454	C2	3233	F4	3436	F2	3921	F1	6490	B1		
2456	G4	3236	G3	3437	F2	3922	F1	6491	A1		
2473	C2	3237	G3	3438	F2	3923	F1	6494	B3		
2493	B2	3238	G3	3439	F2	3924	F2	6495	A3		
2494	A2	3239	G3	3440	F2	3925	F2	6496	B3		
2780	B2	3240	G4	3442	F1	3926	F2	6497	A3		
2783	B2	3241	F4	3442	F1	3927	D2	6780	A1		
2800	A2	3242	F4	3443	F2	3928	F2	6781	B1		
2802	B2	3243	C3	3444	F2	3928	F2	6783	B1		
2804	B2	3246	C3	3450	A4	3929	D2	6784	A1		
2811	B4	3247	G4	3451	A4	3930	D2	6800	B2		
2900	B3	3248	F4	3460	F3	3933	F2	6801	A2		
2902	C1	3249	G4	3462	F2	3936	F1	6802	B2		
2905	C2	3300	D3	3463	F2	3937	D2	6803	A2		
2908	C2	3301	D3	3464	F2	3941	E3	6804	A1		
2909	C2	3302	D4	3465	F2	3942	F4	6805	B2		
2910	C2	3305	C4	3466	E3	3950	B1	6806	A2		
2911	C1	3306	C4	3467	F2	3951	B2	6810	B4		
2912	C2	3307	D4	3468	F2	3952	B2	6811	A4		
2913	D1	3309	D5	3469	F2	3955	B2	6812	A3		
2914	D2	3311	D5	3470	F2	3956	B2	6813	A3		
2920	B2	3313	C4	3471	F2	3957	B2	6820	B4		
2922	D1	3314	C4	3472	F2	3955	C2	6821	A4		
2925	D2	3315	D3	3473	F2	3966	C2	6830	B3		
2928	D2	3316	D3	3480	A2	3968	B3	6831	A3		
2929	D2	3317	D4	3481	B1	3970	D2	6900	A2		
2930	D2	3320	D3	3482	B1	3971	D2	6901	B3		
2931	D1	3321	D3	3490	B1	3973	D2	6920	A2		
2932	E2	3322	D3	3491	B1	3974	D2	6921	B2		
2933	E2	3323	D3	3492	C1	3975	D2	6950	A3		
2934	E2	3324	D4	3495	A3	3976	D2	6951	B3		
2940	E4	3325	D4	3497	A3	3978	B2	6960	A3		

PDP limesco

PD 1 INTERCONNECT

A

B

C

D

E

F

A

B

C

D

E

F

1 2 3 4 5 6 7 8 9

1 2 3 4 5 6 7 8 9

- 1000 E5
- 1001 F5
- 1400 E7
- 1401 B6
- 2350 D7
- 2351 E8
- 2367 C7
- 3360 D7
- 3395 D7
- 3398 C4
- 3399 D4
- 3400 C3
- 3401 E4
- 3402 D4
- 5320 D6
- 5321 E6
- 7358 B7
- 7363 C4
- 7364 D4
- 7365 E4

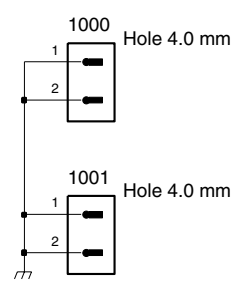
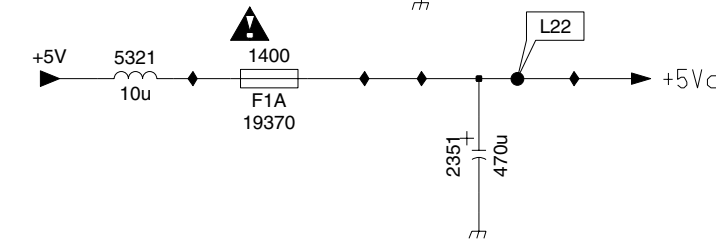
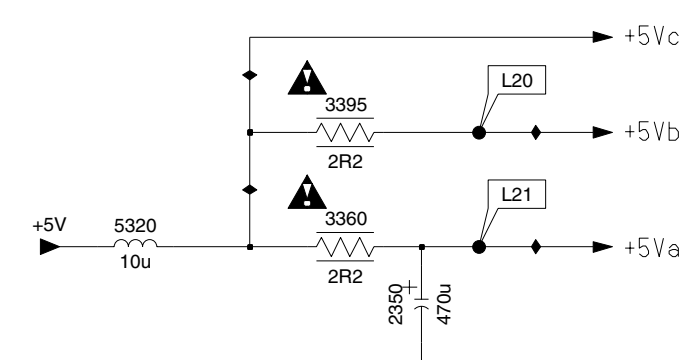
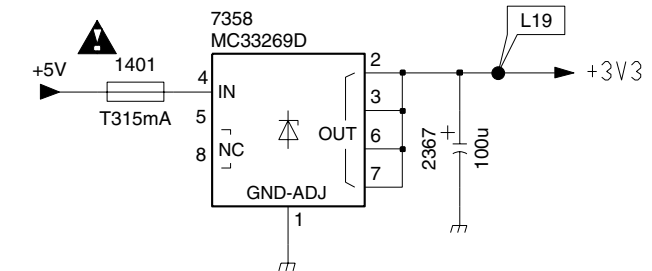
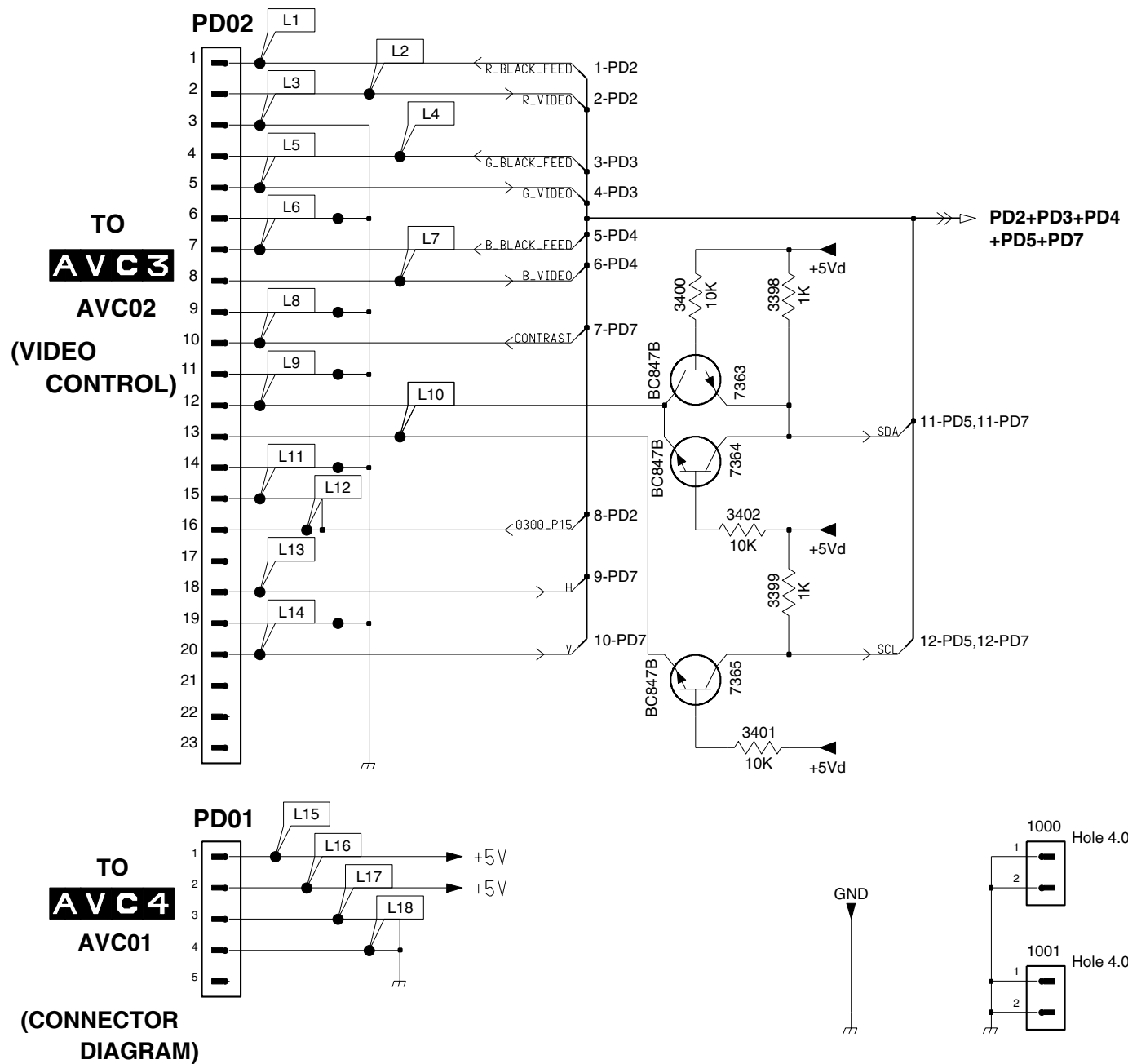

PDP limesco

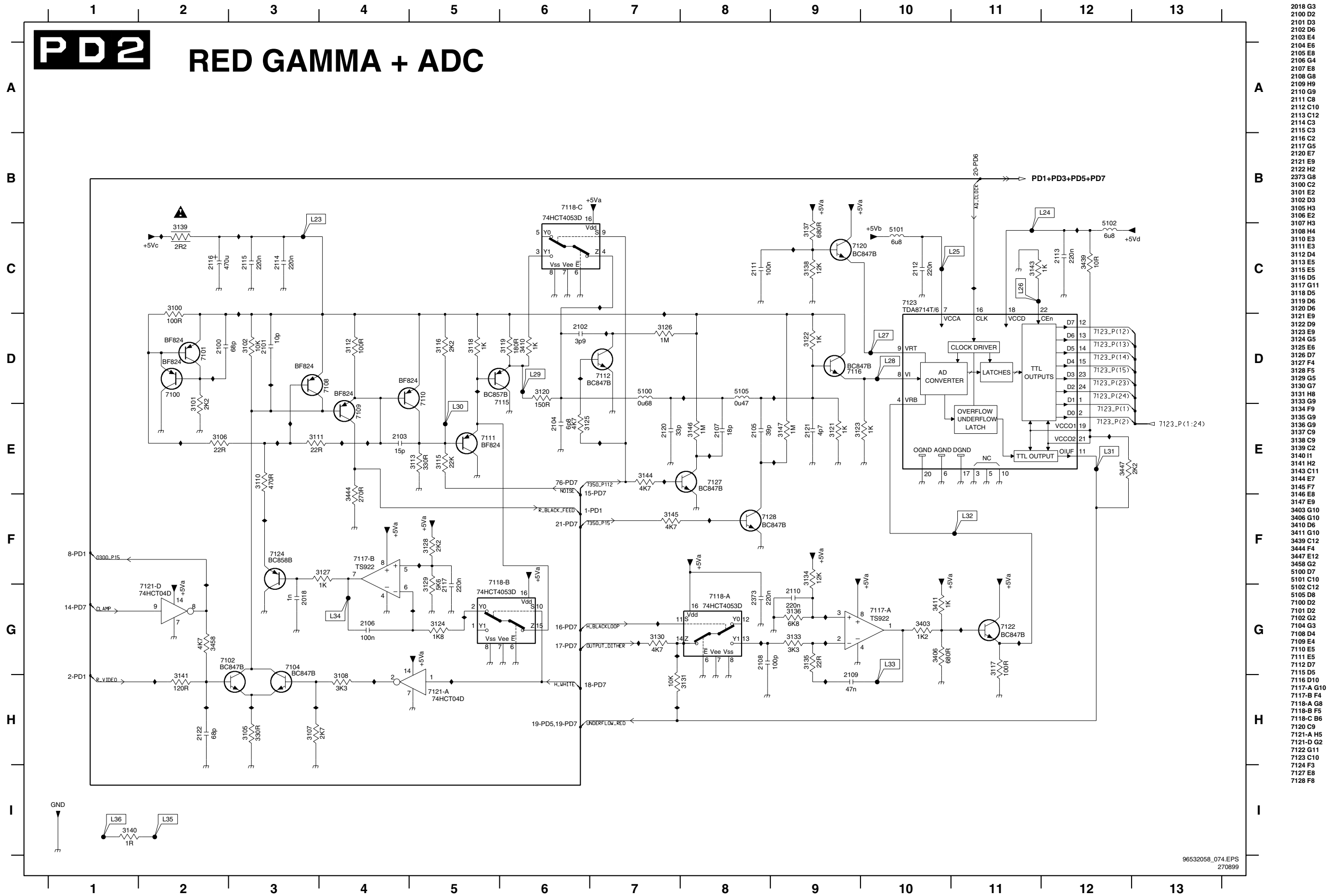

PDP limesco

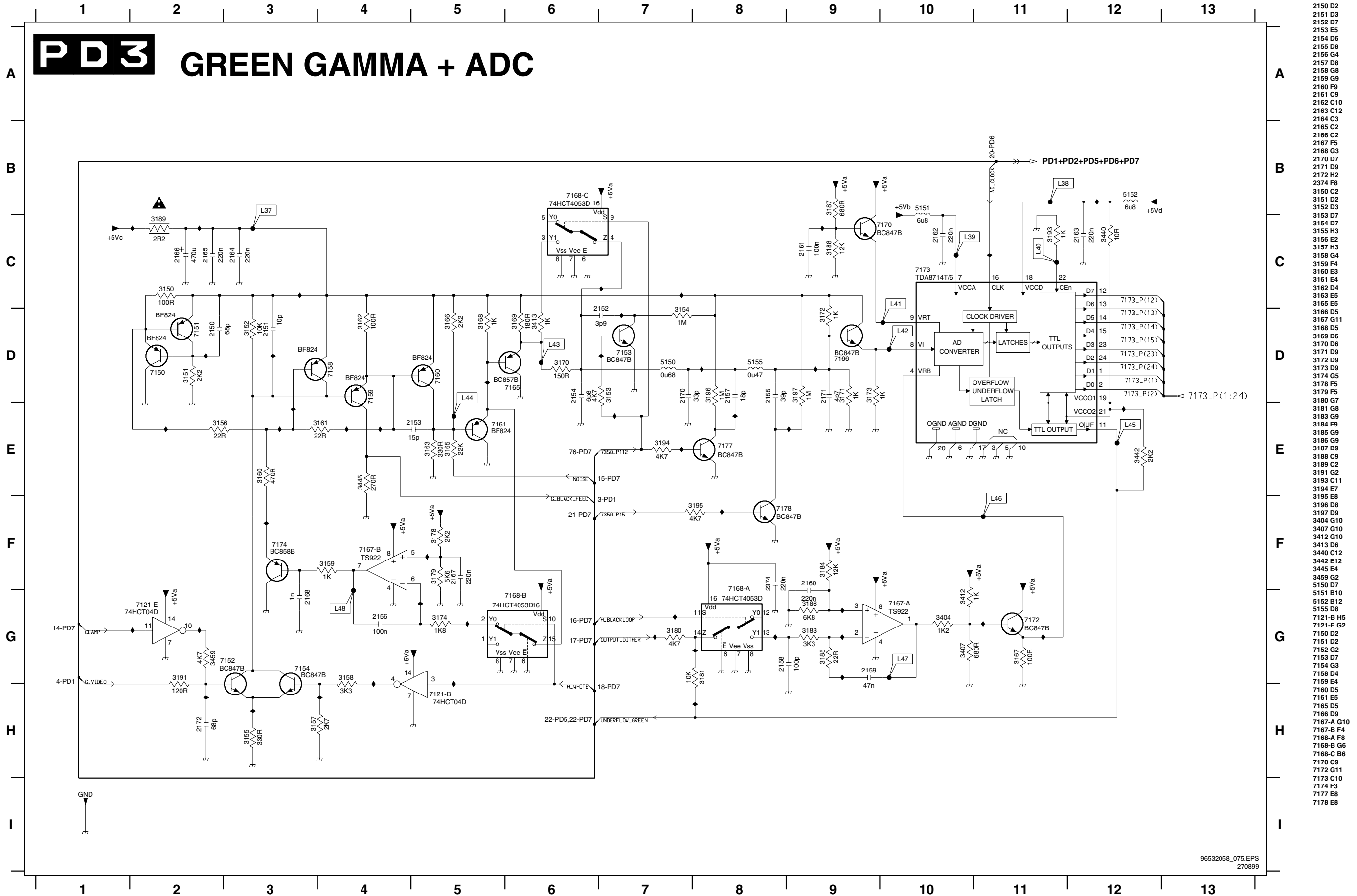

PDP limesco

PD 4 BLUE GAMMA + ADC

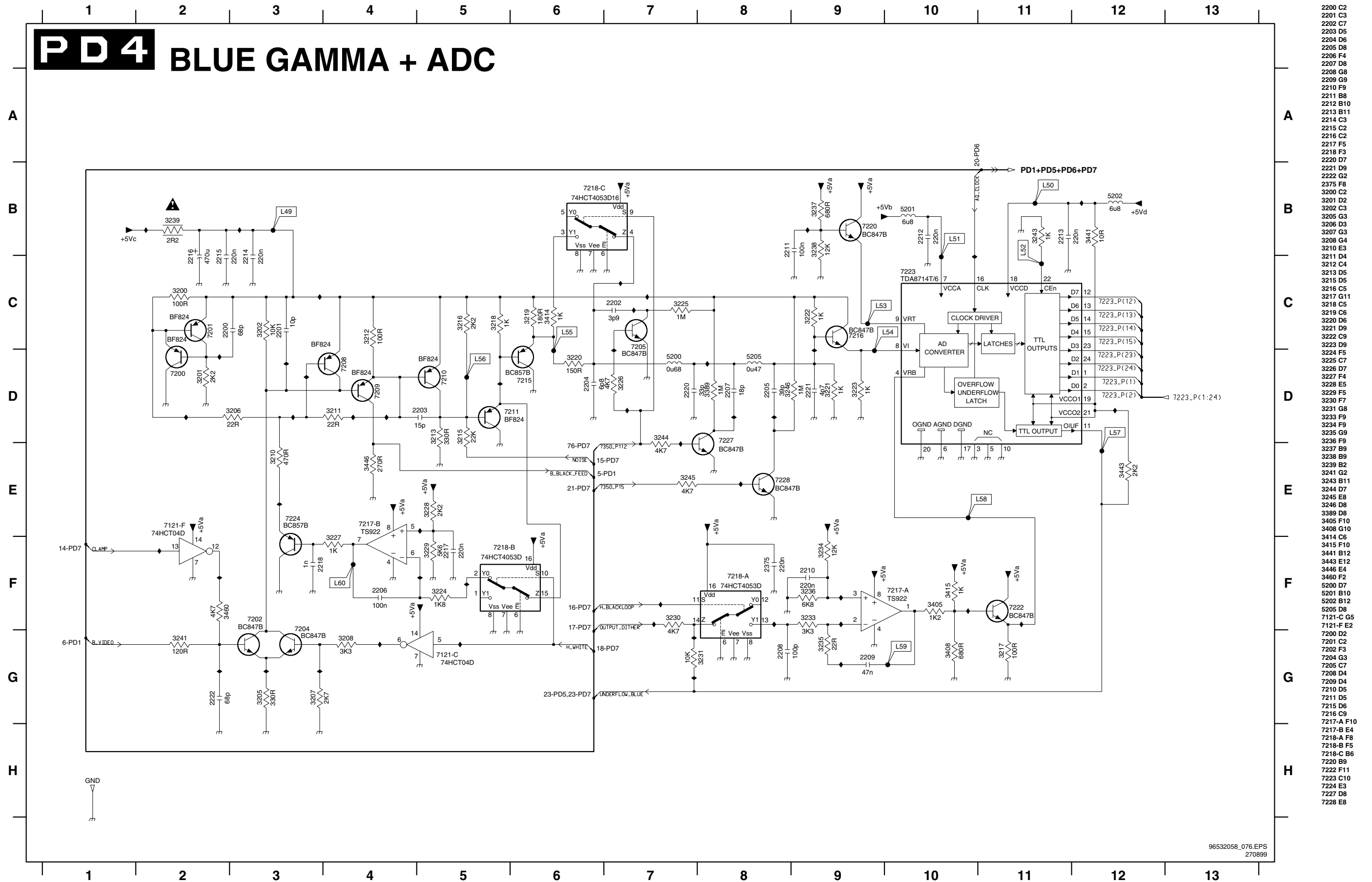

PDP limesco

PD5 SCAN CONVERTER + OSD

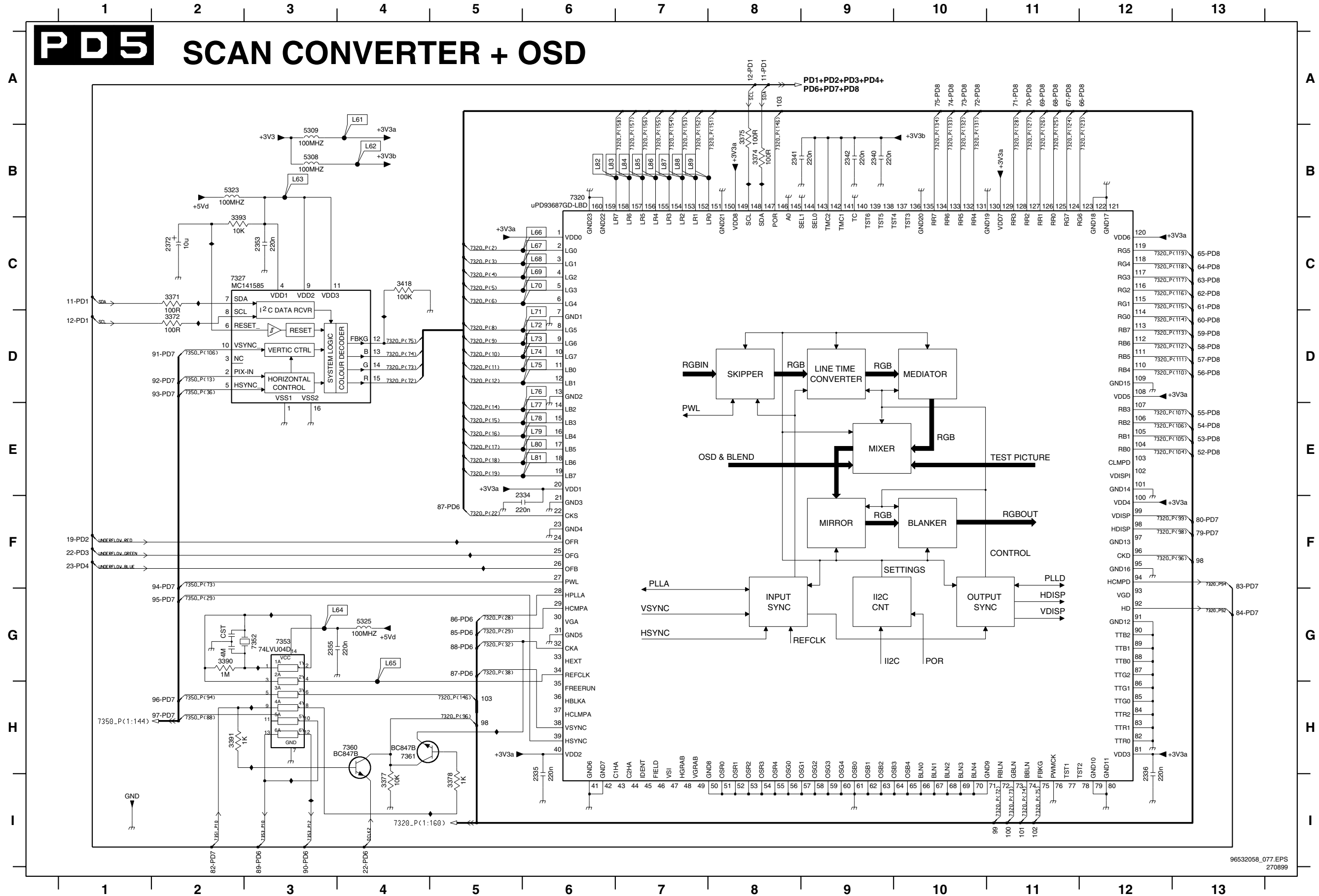

- 2334 F6
- 2335 I6
- 2336 I12
- 2340 B9
- 2341 B8
- 2342 B9
- 2353 C3
- 2355 G3
- 2372 C2
- 3371 C2
- 3372 D2
- 3374 B8
- 3375 B8
- 3377 I4
- 3378 I5
- 3390 G2
- 3391 H2
- 3393 C2
- 3418 C4
- 5308 B3
- 5309 B3
- 5323 B2
- 5325 G4
- 7320 B6
- 7327 C2
- 7352 G3
- 7350 H4
- 7361 H4

PDP limesco

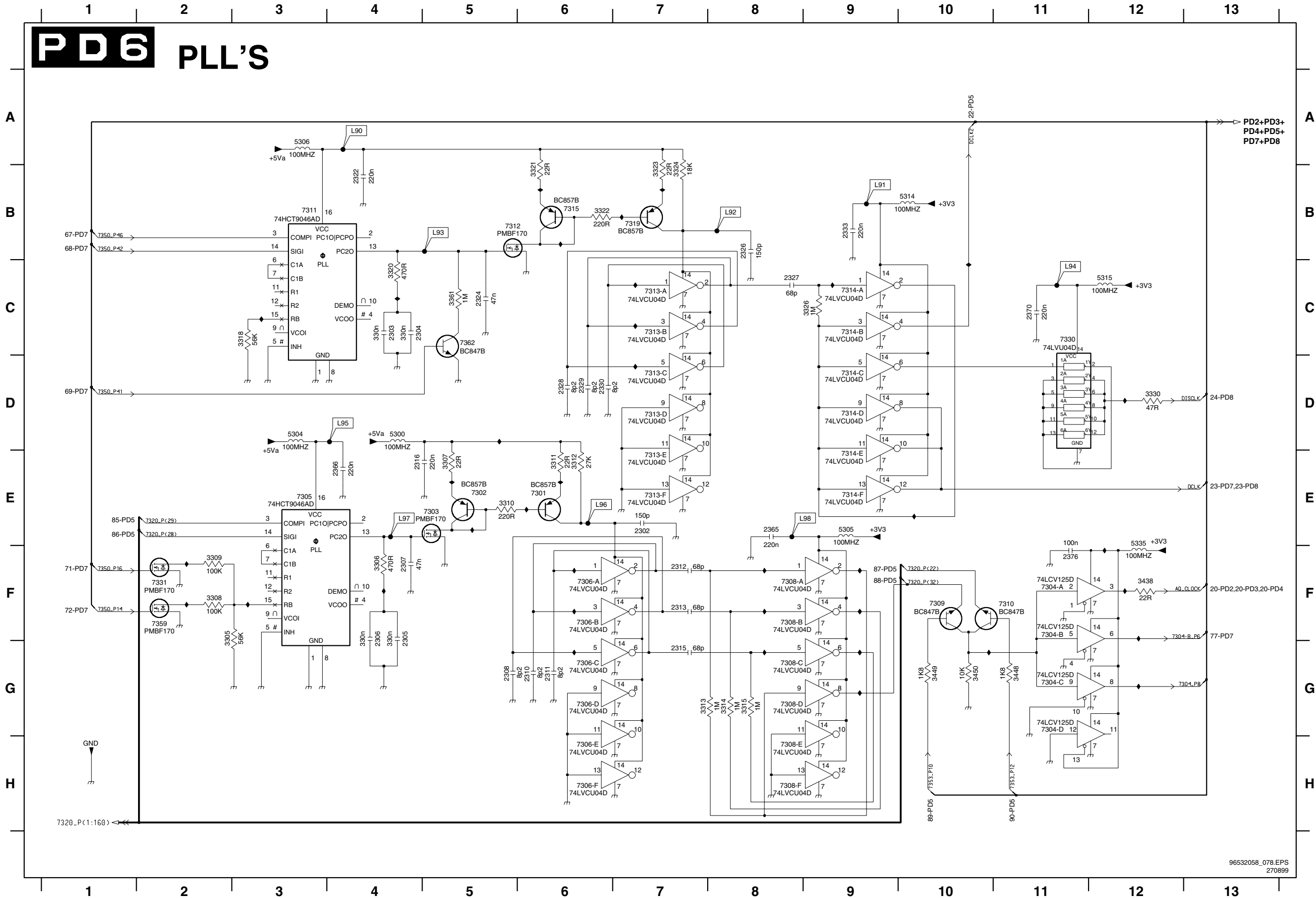

- 2302 E7
- 2303 C4
- 2304 C4
- 2305 F4
- 2306 F4
- 2307 F4
- 2308 G5
- 2310 G6
- 2311 G6
- 2312 F7
- 2313 F7
- 2315 G7
- 2316 E4
- 2322 B4
- 2324 C5
- 2325 B8
- 2327 C8
- 2328 D6
- 2329 D6
- 2330 D6
- 2333 B9
- 2335 E8
- 2366 E4
- 2370 C11
- 2376 F11
- 3305 F2
- 3306 F4
- 3307 E5
- 3308 F2
- 3309 F2
- 3310 E5
- 3311 E6
- 3312 E6
- 3313 G7
- 3314 G8
- 3315 G8
- 3318 C3
- 3320 C4
- 3321 B6
- 3322 B6
- 3323 B7
- 3324 B7
- 3325 C9
- 3330 D12
- 3361 C5
- 3438 F12
- 3448 G11
- 3449 G10
- 3450 G10
- 4000 G11
- 5300 D4
- 5304 D3
- 5305 E9
- 5306 A3
- 5314 B10
- 5315 C12
- 5335 E12
- 7301 E6
- 7302 E5
- 7303 E5
- 7304-A F11
- 7304-B F11
- 7304-C G11
- 7304-D G11
- 7305 E3
- 7306-A F6
- 7306-B F6
- 7306-C G6
- 7306-D G6
- 7306-E H6
- 7306-F H6
- 7308-A F8
- 7308-B F8
- 7308-C G8
- 7308-D G8
- 7308-E H8
- 7308-F H8
- 7309 F10
- 7310 F11
- 7311 B3
- 7312 B5
- 7313-A C7
- 7313-B C7
- 7313-C D7
- 7313-D D7
- 7313-E E7
- 7313-F E7
- 7314-A C9
- 7314-B C9
- 7314-C D9
- 7314-D D9
- 7314-E E9
- 7314-F E9
- 7315 B6
- 7319 B7
- 7330 C11
- 7331 F2
- 7359 F2
- 7362 C5

PDP limesco

PD7 LOGIC CONTROL + I/O

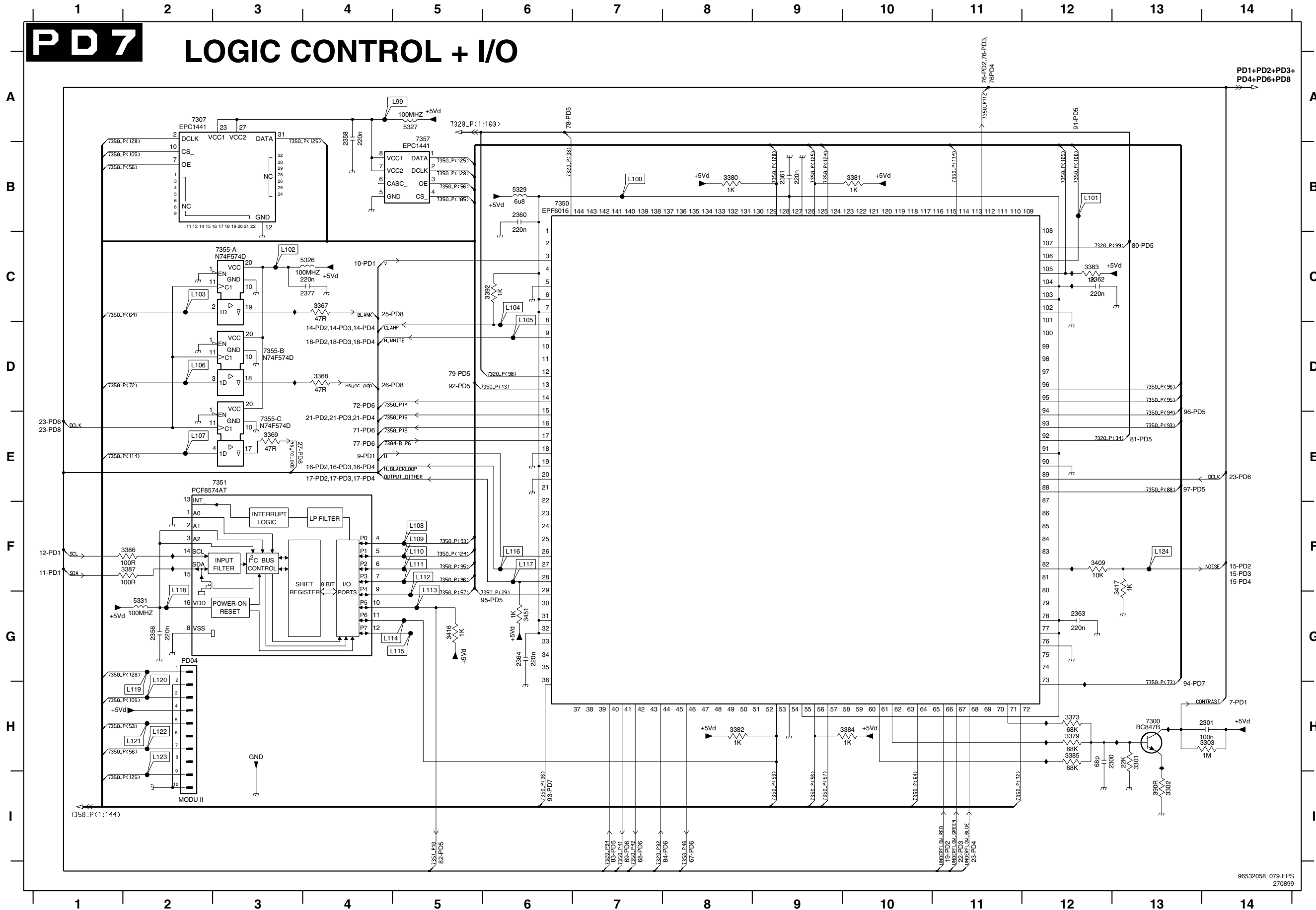

- 2300 H12
- 2301 H14
- 2356 G2
- 2358 A4
- 2360 B6
- 2361 B9
- 2362 C12
- 2363 G12
- 2364 G6
- 2377 C4
- 3301 H13
- 3302 H13
- 3303 H14
- 3367 C4
- 3368 D4
- 3369 E4
- 3373 H12
- 3379 H12
- 3380 B8
- 3381 B10
- 3382 H8
- 3383 C12
- 3384 H10
- 3385 H12
- 3386 F2
- 3387 F2
- 3392 C6
- 3409 F12
- 3416 G5
- 3417 F13
- 3451 G6
- 5326 C4
- 5327 A5
- 5329 B6
- 5331 G2
- 7300 H13
- 7307 A2
- 7350 B6
- 7351 E2
- 7355-A C3
- 7355-B D3
- 7355-C E3
- 7357 A5

PDP limesco

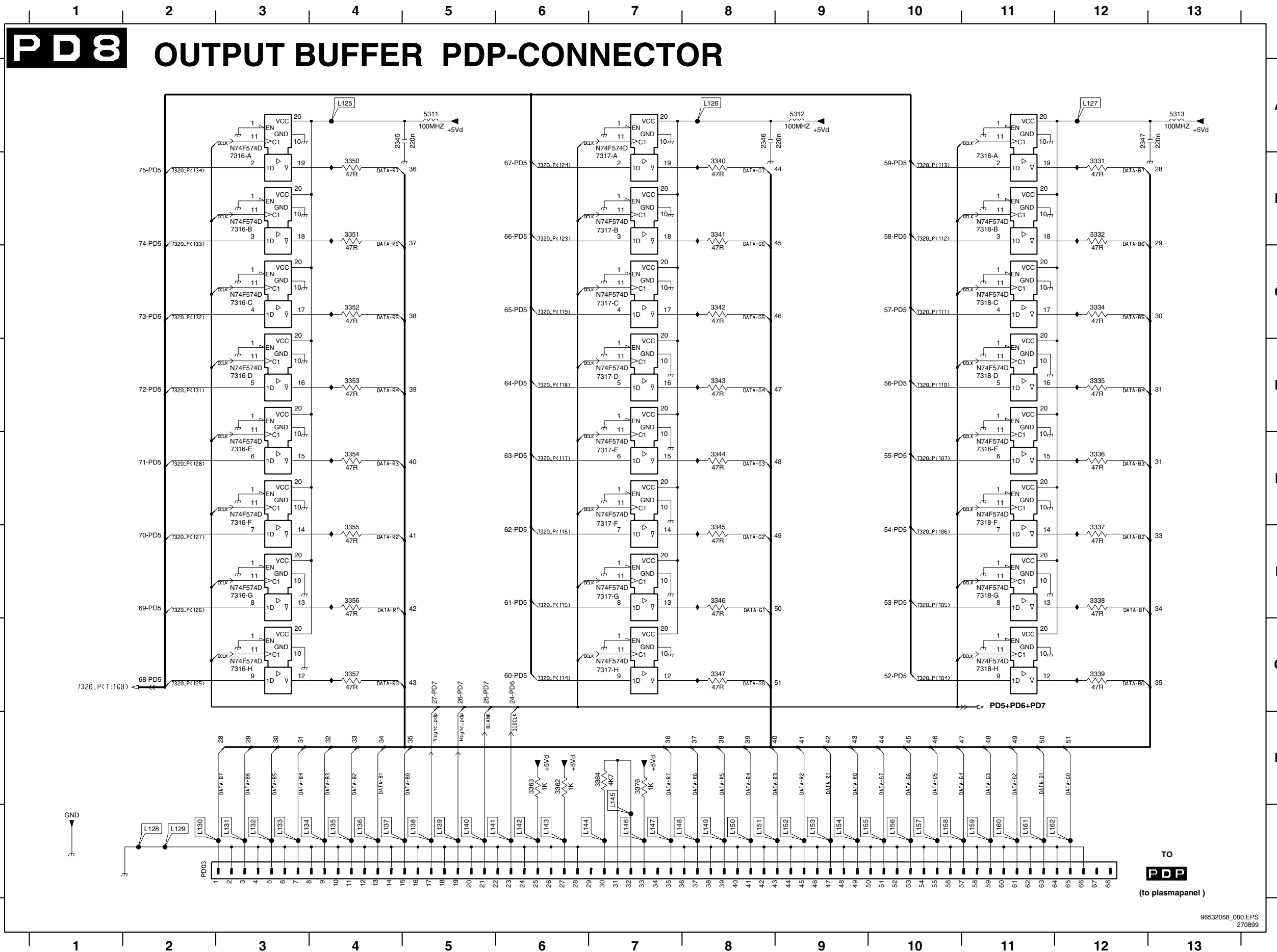

- 2345 B5
- 2346 B8
- 2347 B13
- 3331 B12
- 3332 C12
- 3334 C12
- 3335 D12
- 3336 E12
- 3337 F12
- 3338 G12
- 3339 G12
- 3340 B8
- 3341 C8
- 3342 C8
- 3343 D8
- 3344 E8
- 3345 F8
- 3346 G8
- 3347 G8
- 3350 B4
- 3351 C4
- 3352 C4
- 3353 D4
- 3354 E4
- 3355 F4
- 3356 G4
- 3357 G4
- 3362 I6
- 3363 I6
- 3364 I7
- 3376 I7
- 5311 A5
- 5312 A9
- 5313 A13
- 7316-A B3
- 7316-B C3
- 7316-C C3
- 7316-D D3
- 7316-E E3
- 7316-F F3
- 7316-G G3
- 7316-H G3
- 7317-A B7
- 7317-B C7
- 7317-C C7
- 7317-D D7
- 7317-E E7
- 7317-F F7
- 7317-G G7
- 7317-H G7
- 7318-A B11
- 7318-B C11
- 7318-C C11
- 7318-D D11
- 7318-E E11
- 7318-F F11
- 7318-G G11
- 7318-H G11

PDP limesco

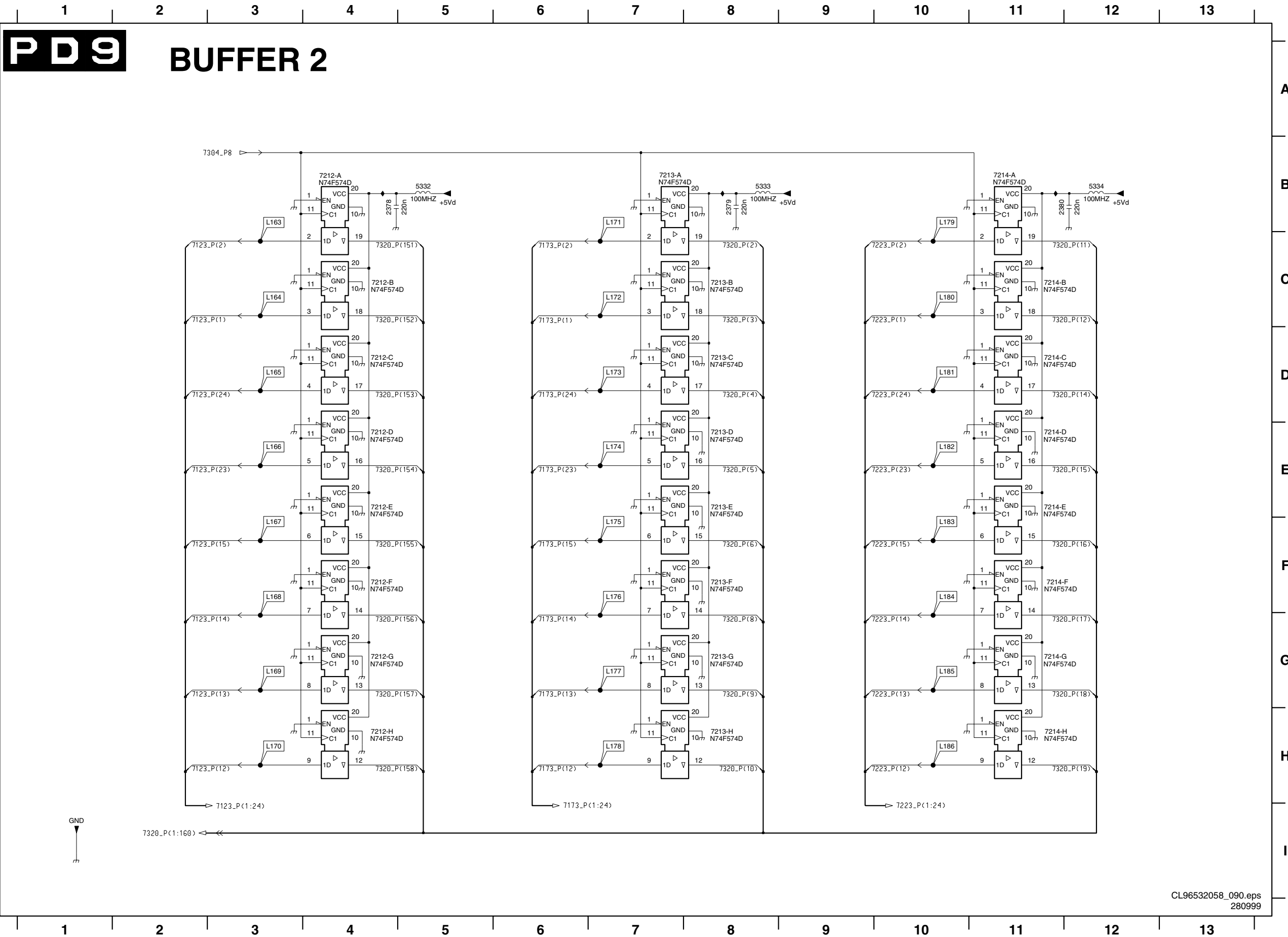

- 2378 B4
- 2379 B8
- 2380 B11
- 5332 B5
- 5333 B8
- 5334 B12
- 7212-A B4
- 7212-B C4
- 7212-C D4
- 7212-D E4
- 7212-E F4
- 7212-F F4
- 7212-G G4
- 7212-H H4
- 7213-A B7
- 7213-B C8
- 7213-C D8
- 7213-D E8
- 7213-E E8
- 7213-F F8
- 7213-G G8
- 7213-H H8
- 7214-A B11
- 7214-B C11
- 7214-C D11
- 7214-D E11
- 7214-E E11
- 7214-F F11
- 7214-G G11
- 7214-H H11

PDP limesco (component side)

0300	G3	2107	B3	2150	A2	2164	A2	2206	B1	2221	B1	2313	D1	2340	E3	2362	D3	2379	C3	3116	A3	3130	B3	3146	B3	3162	A2	3180	B3	3197	B2	3217	B1	3231	B2	3302	E2	3320	E2	3438	E1	7167	B2
0301	G1	2108	B3	2151	A2	2165	A2	2207	B2	2222	A1	2315	D1	2341	E3	2363	D3	2380	C2	3117	B3	3131	B3	3147	B3	3163	B2	3181	B3	3200	A1	3218	A2	3233	B1	3303	D2	3321	E2	3439	C3	7168	B3
0302	G2	2109	B3	2152	B3	2166	A2	2208	B1	2300	F2	2316	D2	2342	E3	2364	C3	3100	A3	3118	A3	3133	B3	3150	A2	3165	A2	3183	B2	3201	B1	3219	A2	3234	B1	3305	D2	3322	E1	3440	C3	7170	B2
0304	C3	2110	B3	2153	A2	2167	B2	2209	B1	2301	F1	2322	F2	2343	E3	2365	D1	3101	B3	3119	A3	3134	B3	3151	B2	3166	A2	3184	B2	3202	A1	3220	B2	3235	B1	3306	D2	3323	F1	3441	C2	7172	B2
1400	F1	2111	B3	2154	B3	2168	B2	2210	B1	2302	D1	2324	F2	2344	F3	2366	D2	3102	A3	3120	B3	3135	B3	3152	A2	3167	B2	3185	B2	3205	A1	3221	B1	3236	B1	3307	D2	3324	F1	3442	C3	7173	B2
1401	G2	2112	B3	2155	B2	2170	B3	2211	B1	2303	F2	2326	F1	2347	F2	2367	F2	3105	A3	3121	B3	3136	B3	3153	B3	3168	A3	3186	B2	3206	A1	3222	B1	3237	B1	3308	D2	3326	F1	3443	C2	7174	B2
2018	B3	2113	C3	2156	B2	2171	B2	2212	B2	2304	F2	2327	F1	2348	F3	2368	F2	3106	B3	3122	B3	3137	B3	3154	B3	3169	A3	3187	B2	3207	A1	3223	B1	3238	B1	3309	D2	3330	F1	3444	A3	7177	B3
2100	A3	2114	A3	2157	B3	2172	A2	2213	C2	2305	D2	2328	F1	2349	F1	2369	F2	3107	A3	3123	B3	3138	B3	3155	A2	3170	B3	3188	B2	3208	A2	3224	B2	3239	A1	3310	D2	3331	F2	3445	A2	7178	B2
2101	A3	2115	A3	2158	B2	2200	A1	2214	A1	2306	D2	2329	F1	2350	F2	2370	F1	3108	A3	3124	B3	3139	A3	3156	A2	3171	B2	3189	A2	3210	B1	3225	B2	3241	A1	3311	D2	3332	F2	3446	A1	7200	B1
2102	B3	2116	A3	2159	B2	2201	A1	2215	A1	2307	D1	2330	F1	2351	F3	2371	F2	3110	A3	3125	B3	3140	G3	3157	A2	3172	B2	3191	A2	3211	A1	3226	B2	3243	C1	3312	D2	3334	F2	3447	C3	7201	A1
2103	A3	2117	B3	2160	B2	2202	B2	2216	A1	2308	D1	2333	F1	2352	F3	2372	B3	3111	A3	3126	B3	3141	A3	3158	A3	3173	B2	3193	C2	3212	A1	3227	B1	3244	B2	3313	D1	3335	F2	3448	E1	7202	A1
2104	B3	2120	B3	2161	B2	2203	A1	2217	B1	2310	D1	2334	F3	2353	D3	2373	F1	3112	A3	3127	B3	3143	C3	3159	B2	3174	B2	3194	B3	3213	B1	3228	B1	3245	B2	3314	D1	3336	F2	3449	E1	7204	A1
2105	B3	2121	B3	2162	B2	2204	B2	2218	B1	2311	D1	2335	F2	2354	C3	2374	F3	3113	B3	3128	B3	3144	B3	3160	B2	3178	B2	3195	B3	3214	A1	3229	B1	3246	B1	3315	D1	3337	F2	3450	E1	7205	B2
2106	B3	2122	A3	2163	C3	2205	B1	2220	B2	2312	D1	2336	F2	2355	D3	2375	C3	3114	A3	3129	B3	3145	B3	3161	A2	3179	B2	3196	B3	3215	A1	3230	B2	3247	D2	3316	F2	3338	F2	3451	C3	7208	A1

3339	F2	3458	A3	7209	A1
3340	F3	3459	A2	7210	A1
3341	F3	3460	A1	7211	A1
3342	F3	5100	B3	7212	C3
3343	F3	5101	C3	7213	C2
3344	F3	5102	C3	7214	C2
3345	F3	5105	B3	7215	A1
3346	F3	5150	B3	7216	B1
3347	F2	5151	C3	7217	B1
3350	F3	5152	C3	7218	B2
3351	F3	5155	B3	7220	B1
3352	F3	5200	B2	7222	B1
3353	F3	5201	C2	7223	C2
3354	F3	5202	C2	7224	B1
3355	F3	5205	B2	7227	B2
3356	F3	5300	D2	7228	B2
3357	F3	5304	D2	7300	O2
3360	G1	5305	D1	7301	O2
3361	F2	5306	F2	7302	O2
3362	G3	5308	F2	7303	O2
3363	G3	5309	F2	7304	E1
3364	G3	5311	F3	7305	O2
3367	F3	5312	F3	7306	O1
3368	F3	5313	F2	7307	O3
3369	F2	5314	F1	7308	O1
3371	F2	5315	E1	7309	E1
3372	F2	5320	G1	7310	F1
3373	F2	5321	G1	7311	F1
3374	F2	5323	E2	7312	E2
3375	F3	5325	F3	7313	F1
3376	G3	5326	F3	7314	F1
3377	F2	5327	D3	7315	E1
3378	E2	5329	D3	7316	F3
3379	D2	5331	E3	7317	F3
3380	O3	5332	C3	7318	F2
3381	D3	5333	C3	7319	E1
3382	D3	5334	C2	7320	F3
3383	D3	5335	E1	7327	E2
3384	D3	7100	A3	7330	F1
3385	D2	7101	A3	7331	O2
3386	F3	7102	A3	7350	O3
3387	F3	7104	A3	7351	E3
3389	B2	7108	A3	7352	E3
3390	F2	7109	A3	7353	F3
3391	F2	7110	A3	7355	F3
3392	D3	7111	A3	7357	O3
3393	F2	7112	B3	7358	F2
3395	F1	7115	A3	7359	O2
3398	F3	7116	B3	7360	E2
3399	F3	7117	B3	7361	E2
3400	F3	7118	B3	7362	F1
3401	F3	7120	B3	7363	F3
3402	F3	7121	A3	7364	F3
3403	D3	7122	B3	7365	F3
3404	B2	7123	B3		
3405	B1	7124	B3		
3406	B3	7127	B3		
3407	B2	7128	B3		
3408	B1	7150	B2		
3409	D3	7151	A2		
3410	B3	7152	A2		
3411	B3	7153	B3		
3412	B2	7154	A2		
3413	B2	7158	A2		
3414	B2	7159	A2		
3415	B1	7160	A2		
3416	E3	7161	A3		
3417	D3	7165	B2		
3418	E2	7166	B2		

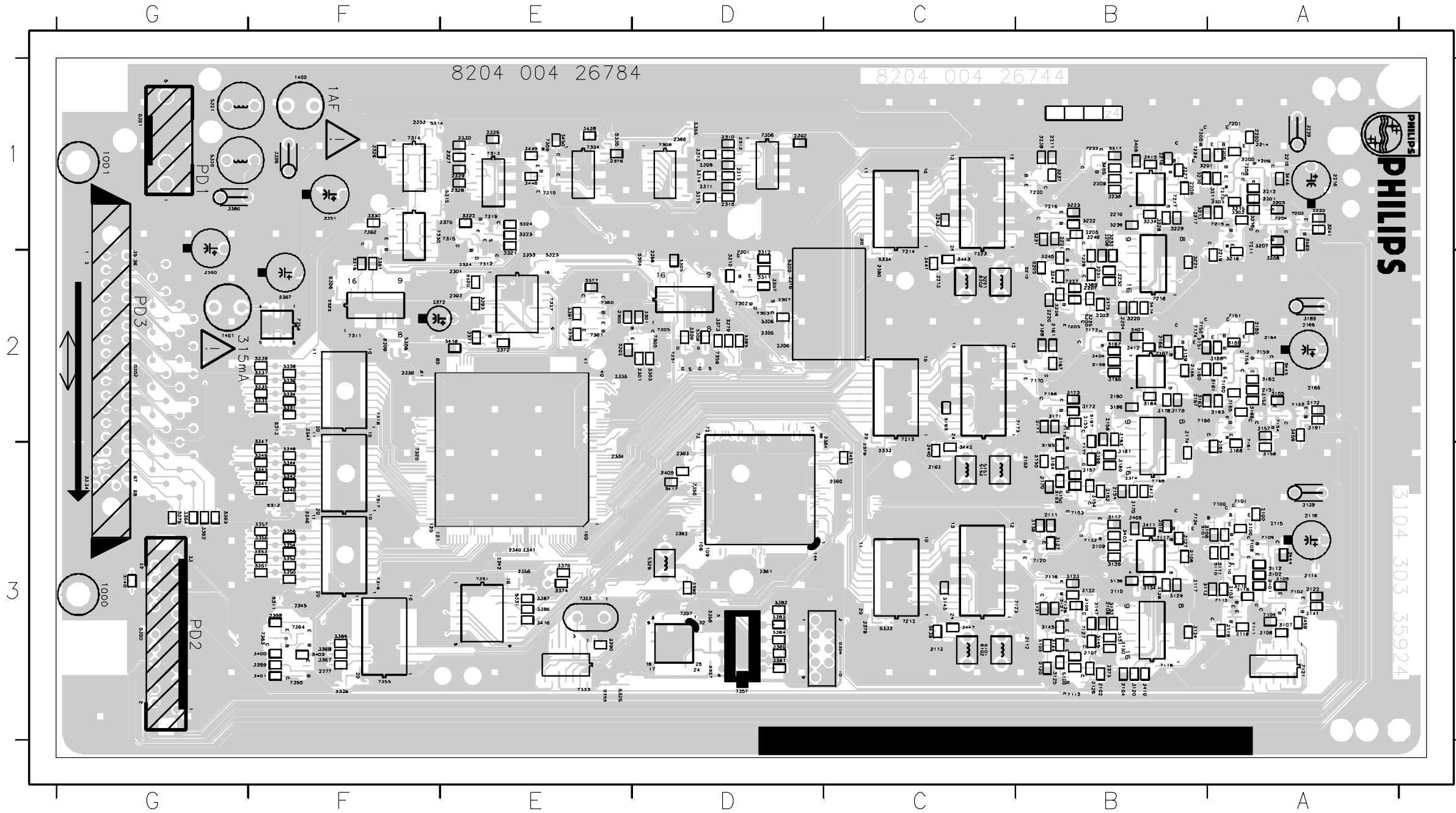

PDP limesco (copper side)

