



CONSUMER SERVICES TECHNICAL
EDUCATION GROUP PRESENTS

L-69

duet™

GAS AND ELECTRIC DRYERS

Model Numbers:
GGW9200L & GEW9200L



JOB AID
Part No. 8178071

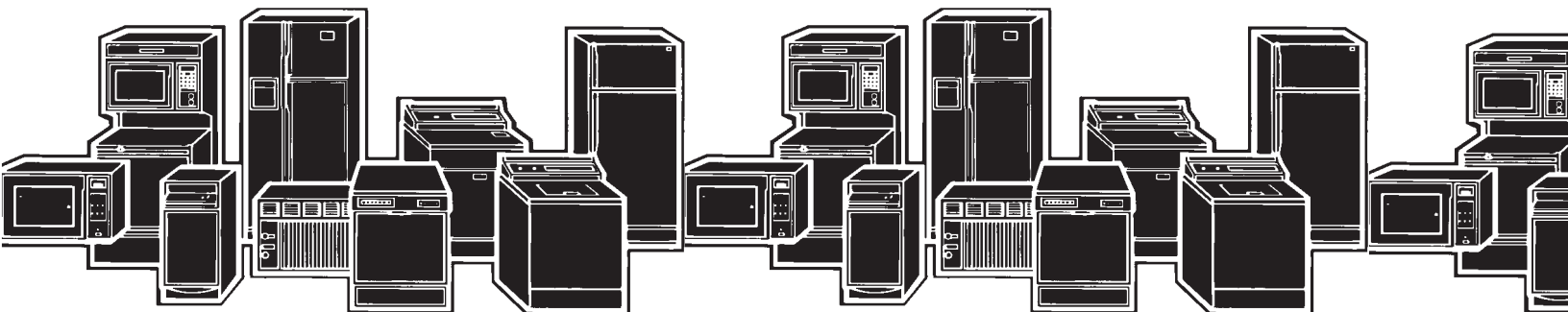

FORWARD

This Whirlpool Job Aid, “Duet™ Gas and Electric Dryers,” (Part No. 8178071), provides the technician with information on the operation and service of the Gas and Electric Dryers. It is to be used as a training Job Aid and Service Manual. For specific information on the model being serviced, refer to the “Use and Care Guide,” or “Tech Sheet” provided with the dryer.

The Wiring Diagrams used in this Job Aid are typical and should be used for training purposes only. Always use the Wiring Diagram supplied with the product when servicing the unit.

GOALS AND OBJECTIVES

The goal of this Job Aid is to provide detailed information that will enable the service technician to properly diagnose malfunctions and repair the Whirlpool Gas and Electric Dryers.

The objectives of this Job Aid are to:

- Understand and follow proper safety precautions.
- Successfully troubleshoot and diagnose malfunctions.
- Successfully perform necessary repairs.
- Successfully return the Gas or Electric Dryer to its proper operational status.

WHIRLPOOL CORPORATION assumes no responsibility for any repairs made on our products by anyone other than Authorized Service Technicians.

TABLE OF CONTENTS

	Page
GENERAL	1-1
Important Safety Information	1-1
Model & Serial Number Designations	1-2
Model & Serial Number Label And Tech Sheet Locations	1-3
Specifications	1-4
Warranty	1-5
INSTALLATION INFORMATION	2-1
Electrical Requirements For Electric Dryers	2-1
Electrical Connections For Electric Dryers	2-3
Electrical Requirements For Gas Dryers	2-8
Gas Supply Requirements	2-9
Optional Exhaust Information	2-10
Leveling The Dryer	2-10
Reversing The Door Swing	2-11
Installing The Optional Pedestal	2-14
Optional Stack Kit (#8519492)	2-16
PRODUCT OPERATION	3-1
COMPONENT ACCESS	4-1
Component Locations	4-1
Removing The Machine Control Electronics Board	4-2
Removing The Console & The Touchpad Subassembly	4-4
Removing The Door Switch	4-6
Removing The Thermal Fuse, Thermistor, Drive Motor, & Belt Switch	4-7
Removing The Heater, The High-Limit Thermostat, & Thermal Cutoff	4-10
Removing The Belt, Drum, & Rollers	4-11
Removing The Drum Light Socket	4-14
Removing The Moisture Sensor	4-15
COMPONENT TESTING	5-1
Making Electrical Tests	5-1
Drive Motor	5-2
Heater	5-3
Thermal Fuse	5-4
Thermistor	5-5
Thermal Cutoff (Electric Dryers Only)	5-6
Gas Valve (Gas Dryers Only)	5-7
Moisture Sensor	5-8
Console Pushbuttons & LEDs	5-8
Door Switch	5-10
DIAGNOSIS AND TROUBLESHOOTING	6-1
Diagnosis	6-1
Display Fault/Error Codes	6-1
Diagnostic Tests	6-1
Keypad Test	6-2
Additional Tests	6-2
Troubleshooting Guide	6-3
WIRING DIAGRAMS	7-1

— NOTES —

GENERAL

IMPORTANT SAFETY INFORMATION

Your safety and the safety of others is very important.

Important safety messages have been provided in this Job Aid. Always read and obey all safety messages.



This is the safety alert symbol. This symbol alerts you to hazards that can kill or hurt you and others.

All safety messages will be preceded by the safety alert symbol and the word **“WARNING.”**

All safety messages will identify the hazard, tell you how to reduce the chance of injury, and tell you what can happen if the instructions are not followed.

WARNING

ELECTRICAL SHOCK HAZARD

**Disconnect power before servicing.
Replace all panels before operating.
Failure to do so could result in death or electrical shock.**

WARNING

FIRE HAZARD

**Disconnect gas supply before servicing.
Replace all panels before operating.
Failure to do so could result in death or electrical shock.**

ELECTROSTATIC DISCHARGE (ESD) SENSITIVE ELECTRONICS

ESD problems are present everywhere. ESD may damage or weaken the electronic control assembly. The new control assembly may appear to work well after repair is finished, but failure may occur at a later date due to ESD stress.

- Use an antistatic wrist strap. Connect the wrist strap to a green ground connection point or unpainted metal in the appliance; or touch your finger repeatedly to a green ground connection point or unpainted metal in the appliance.
- Before removing the part from its package, touch the antistatic bag to a green ground connection point or unpainted metal in the appliance.
- Avoid touching electronic parts or terminal contacts. Handle the electronic control assembly by the edges only.
- When repackaging the failed electronic control assembly in an antistatic bag, observe the above instructions.

MODEL & SERIAL NUMBER DESIGNATIONS

MODEL NUMBER (DRYER)

MODEL NUMBER	G	E	W	9200	L	W	0
PRODUCT GROUP	G = Domestic Laundry Gold						
PRODUCT IDENTIFICATION	E = Electric Dryer G = Gas Dryer						
FEATURE CODE	W = High Efficiency						
FEATURE LEVEL							
YEAR OF INTRODUCTION	L = 2002						
COLOR CODE	W = White / Grey Q = White / Blue						
ENGINEERING CHANGE	0 = Basic, 1 = 1st Revision, 2 = 2nd Revision						

MODEL NUMBER (PEDESTAL)

MODEL NUMBER	L	A	B	27	0	0	L	Q	0
PRODUCT GROUP	L = Domestic Laundry								
PRODUCT IDENTIFICATION	A = Laundry Accessory								
FEATURE CODE	B = Pedestal Base								
PRODUCT WIDTH									
FILLER									
FILLER									
YEAR OF INTRODUCTION									
COLOR CODE	K = Graphite (Laundry) Q = White On White T = Biscuit On Biscuit								
ENGINEERING CHANGE									

SERIAL NUMBER (DRYER)

SERIAL NUMBER	M	L	16	00036
MANUFACTURING SITE	MARION, OH			
YEAR OF PRODUCTION	L = 2001			
WEEK OF PRODUCTION				
PRODUCT SEQUENCE NUMBER				

SERIAL NUMBER (PEDESTAL)

SERIAL NUMBER	CT	L	01	10001
MANUFACTURING SITE	TAYLOR IND., MANSFIELD, OH			
YEAR OF PRODUCTION	L = 2001			
WEEK OF PRODUCTION				
PRODUCT SEQUENCE NUMBER				

MODEL & SERIAL NUMBER LABEL AND TECH SHEET LOCATIONS

The Model/Serial Number label and Tech Sheet locations are shown below.

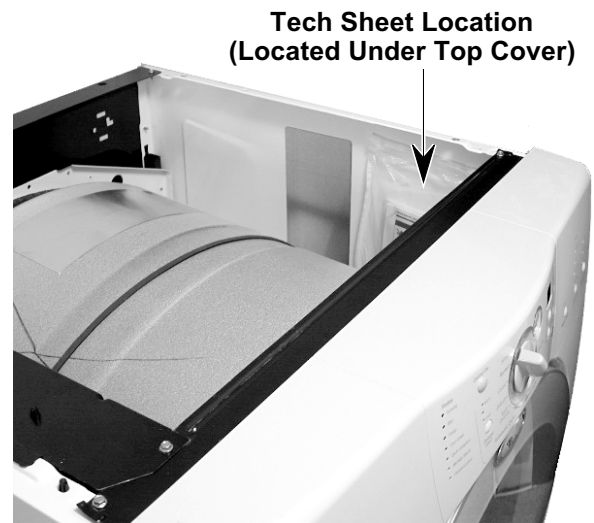

SPECIFICATIONS

BRAND	Whirlpool	Whirlpool	Whirlpool	Whirlpool
MODEL NUMBER	GEW9200LW	GEW9200LQ	GGW9200LW	GGW9200LQ
FUEL	Electric	Electric	Gas	Gas
CABINET COLOR	White/Grey	White/Blue	White/Grey	White/Blue
INSTALLATION OPTIONS				
FREESTANDING	X	X	X	X
PEDESTAL	X	X	X	X
STACKABLE	X	X	X	X
CAPACITY (cu ft)	7.0	7.0	7.0	7.0
CAPACITY NOMENCLATURE	SUPER CAPACITY	SUPER CAPACITY	SUPER CAPACITY	SUPER CAPACITY
AUTO CYCLE TERMINATION				
ENHANCED EH (Fuzzy Logic)	X	X	X	X
SENSION CONTROL	X	X	X	X
LINT HANDLING				
FRONT SCREEN	X	X	X	X
CONTROLS	Electronic	Electronic	Electronic	Electronic
CONTROL LOCK OUT	X	X	X	X
CONTROL TYPE PRIMARY	Rotary	Rotary	Rotary	Rotary
CONTROL TYPE SECONDARY	Tap Touch	Tap Touch	Tap Touch	Tap Touch
NON-HEATED DRY RACK	X	X	X	X
MULTI-VENT OPTION	4 WAY	4 WAY	4 WAY	4 WAY
UTILITIES				
FREQUENCY	60HZ	60HZ	60HZ	60HZ
MOTOR RATING	1/3 HP	1/3 HP	1/3 HP	1/3 HP
HEATER ELEMENT	5400W	5400W		
GAS BTU			22,000	22,000
RATED AMPERAGE (ELECTRIC)	28	28		
DIMENSIONS (UNCRATED)				
HEIGHT OF TOP*	37 2/5	37 2/5	37 2/5	37 2/5
TOTAL HEIGHT*	37 2/5	37 2/5	37 2/5	37 2/5
WIDTH	27	27	27	27
DEPTH				
ELECTRIC	30 3/4	30 3/4	30 3/4	30 3/4
GAS + 1 INCH	31 3/4	31 3/4	31 3/4	31 3/4
DEPTH DOOR OPEN	51	51	51	51
PRODUCT WEIGHT	143	143	143	143
WARRANTY				
LABOR	1 Yr	1 Yr	1 Yr	1 Yr
PARTS	1 Yr	1 Yr	1 Yr	1 Yr
PORCELAIN TOP	5 Yr	5 Yr	5 Yr	5 Yr
MOTOR/ELEMENT/BURNER	1 Yr	1 Yr	1 Yr	1 Yr
CONTROLS	2 Yr	2 Yr	2 Yr	2 Yr

WARRANTY

FULL ONE YEAR WARRANTY ON MECHANICAL AND ELECTRICAL PARTS

For one year from the date of purchase, Whirlpool will pay for replacement parts and repair labor for mechanical or electrical parts to correct defects in materials or workmanship. Whirlpool will perform necessary adjustments. Service must be provided by a Whirlpool Service Department in Canada or an authorized agent.

NOTE: Exhausting this dryer with a plastic vent can void this warranty. See the "Installation Instructions" for the exhaust requirements for this dryer.

LIMITED TWO YEAR WARRANTY ON SENSOR SMART™ ELECTRONIC CONTROL BOARD

For two years from the date of purchase, Whirlpool will replace the electronic control board if defective in materials or workmanship. You will be charged for labor after the first year.

LIMITED FIVE YEAR WARRANTY ON PORCELAIN TOP

For five years from the date of purchase, Whirlpool will replace parts for the porcelain top should it be perforated by rust or chippage.

PEDESTAL OPTION WARRANTY

FULL ONE YEAR WARRANTY ON MECHANICAL PARTS

For one year from the date of purchase, when Pedestal is installed with this dryer and operated according to the instructions provided in the Owner's Manual, supplier will repair or replace any mechanical parts if defective in material or workmanship.

— NOTES —

INSTALLATION INFORMATION

ELECTRICAL REQUIREMENTS FOR ELECTRIC DRYERS

It is your responsibility:

- To contact a qualified electrical installer.
- To be sure that the electrical connections are adequate and in conformance with the National Electrical Code, ANSI/NFPA 70-latest edition and all local codes and ordinances.

A copy of the above code standards can be obtained from: National Fire Protection Association, Batterymarch Park, Quincy, MA 02269.

- To supply the required 3 or 4 wire, single phase, 120/240-volt, 60 Hz, AC-only electrical supply (or 3 or 4 wire, 120/208-volt electrical supply, if specified on the serial/rating plate) on a separate 30-ampere circuit, fused on both sides of the line. A time-delay fuse or circuit breaker is recommended. Connect the wiring to an individual branch circuit.
- Do not use an extension cord.
- If codes permit and a separate ground wire is used, it is recommended that a qualified electrician determine that the ground path is adequate.

GROUNDING INSTRUCTIONS

WARNING

ELECTRICAL SHOCK HAZARD

Check with a qualified electrician if you are in doubt as to whether the appliance is properly grounded. Do not modify the power supply cord plug. If it will not fit the outlet, have a proper outlet installed by a qualified electrician.

Improper connection of the equipment grounding conductor can result in a risk of electrical shock.

For a grounded, cord-connected dryer:

This dryer must be grounded. In the event of malfunction or breakdown, grounding will reduce the risk of electric shock by providing a path of least resistance for electric current. This dryer uses a cord having an equipment-grounding conductor and a grounding plug. The plug must be plugged into an appropriate outlet that is properly installed and grounded in accordance with all local codes and ordinances.

For a permanently connected dryer:

This dryer must be connected to a grounded metal, permanent wiring system, or an equipment-grounding conductor must be run with the circuit conductors and connected to the equipment-grounding terminal or lead on the dryer.

ELECTRICAL CONNECTION

If using a power supply cord, the cord must be:

- U.L.-listed or CSA certified
- 120/240 volt minimum
- 30 amp
- Type SRD or SRDT
- At least 4 ft (122 cm) long

The wires that connect to the dryer must end in ring terminals, or spade terminals with up-turned ends.

If the outlet looks like this:

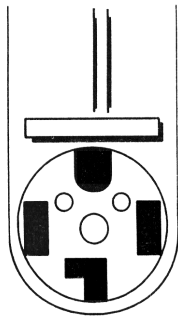

4-Wire Receptacle (14-30R)

Choose a 4-wire power supply cord with ring, or spade terminals, and a UL-approved strain relief. The 4-wire power supply cord must have 4, 10 gauge solid copper wires, and match a 4-wire receptacle, NEMA type 14-30R. The fourth wire (ground conductor) must be identified with a green cover, and the neutral conductor by a white cover.

If the outlet looks like this:

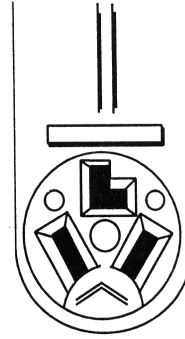

3-Wire Receptacle (10-30R)

Choose a 3-wire power supply cord with ring, or spade terminals, and a UL-approved strain relief. The 3-wire power supply cord, must have three #10 copper wires, and match a 3-wire receptacle, NEMA type 10-30R.

If connecting by direct wire:

The power supply cable must match power supply (4-wire or 3-wire) and be:

- Flexible armored or nonmetallic sheathed copper cable (with ground wire). All current-carrying wires must be insulated.
- 10 gauge solid copper wire (do not use aluminum).
- At least 4 ft (122 cm) long.

All wire connections are to be made to the terminal block, located on the rear of the appliance. The terminal block and its cover location is shown below.

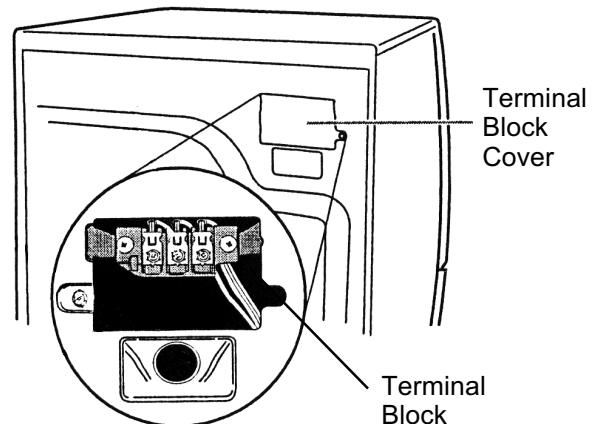

ELECTRICAL CONNECTIONS FOR ELECTRIC DRYERS

! WARNING

ELECTRICAL SHOCK HAZARD

Disconnect power before making electrical connections.

Securely tighten all electrical connections.

Failure to do so can result in death or electrical shock.

NOTE: This section shows the installation for:

- 4-wire power supply cord connection
- 4-wire direct connection
- 3-wire power supply cord connection
- 3-wire direct connection
- Optional 3-wire connection

4-WIRE POWER SUPPLY CORD CONNECTION

IMPORTANT: A 4-wire connection is required for use in mobile homes, and where local codes do not permit the use of 3-wire connections.

1. Remove the terminal block cover hold-down screw and open the cover at the back of the dryer.
2. Remove the center terminal block screw.
3. Remove the appliance ground wire (green with a yellow tracer) from the external ground connector screw, and reconnect it to the center, silver terminal block screw.

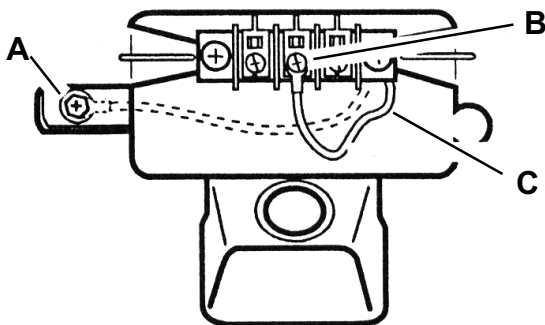

- A. External ground connector (dotted lines show position of neutral ground wire before being moved)
- B. Center, silver terminal block screw
- C. Neutral grounding wire (green/yellow) in harness

4. Connect the ground wire (green or bare) of the power supply cord to the external ground conductor screw.
5. Connect the neutral wire (white or center wire) of the power supply cord to the center screw of the terminal block.

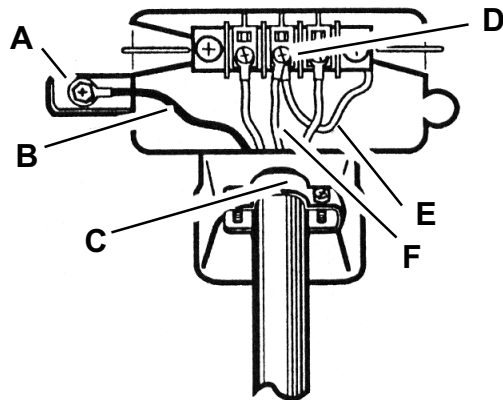

- A. External ground connector
- B. Green or bare copper wire of power supply cord
- C. 3/4" (1.9 cm) UL-listed strain relief
- D. Center, silver terminal block screw
- E. Neutral grounding wire (green/yellow)
- F. Neutral wire (white)

6. Connect the ends of the remaining power supply wires to the left and right terminal block screws.

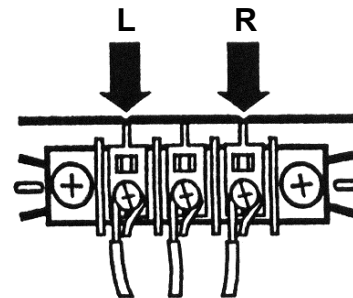

7. Check the wire connections and make sure that they are all tight.
8. Tighten the strain relief clamp screws.
9. Insert the tab of the terminal block cover into the slot of the dryer rear panel and secure the cover with its mounting screw.

4-WIRE DIRECT CONNECTION

1. Strip 5" (12.7cm) of outer covering from the end of the cable.
2. Cut 1-1/2" (3.8 cm) from the 3 insulated wires. Do not cut the bare ground wire.
3. Strip 1" (2.5 cm) of insulation from the ends of the three wires.
4. Twist the loose wire strands together on each wire and form a hook in the bare wire ends.

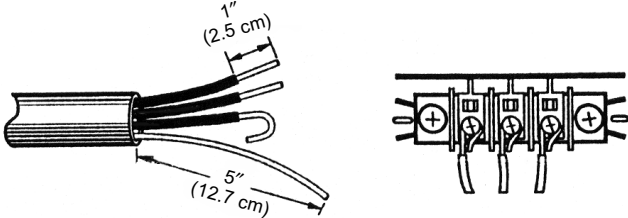

5. Remove the terminal block cover hold-down screw and open the cover at the back of the dryer.
6. Remove the center terminal block screw.
7. Remove the appliance ground wire (green with a yellow tracer) from the external ground connector screw, and reconnect it to the center, silver terminal block screw.

8. Connect the ground wire (green or bare) of the power supply cable to the external ground conductor screw.

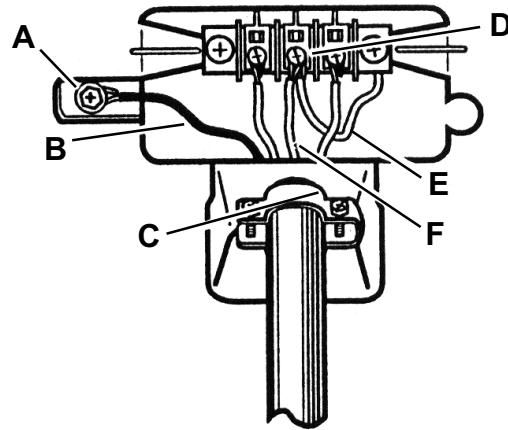

- A. External ground connector
- B. Green or bare copper wire of power supply cord
- C. 3/4" (1.9 cm) UL-listed strain relief
- D. Center, silver terminal block screw
- E. Neutral grounding wire (green/yellow)
- F. Neutral wire (white)

9. Connect the end of the neutral (white) wire of the power supply cable to the center screw of the terminal block.
10. Connect the ends of the remaining power supply wires to the left and right terminal block screws.

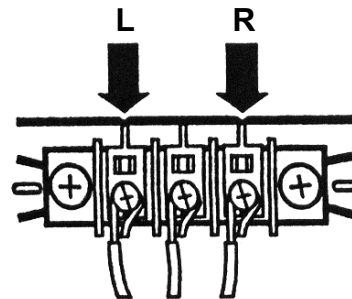

11. Check the wire connections and make sure that they are all tight.
12. Tighten the strain relief clamp screws.
13. Insert the tab of the terminal block cover into the slot of the dryer rear panel and secure the cover with its mounting screw.

3-WIRE POWER SUPPLY CORD CONNECTION

IMPORTANT: Use this procedure only where local codes permit connecting a cabinet-ground conductor to the neutral wire.

1. Remove the terminal block cover hold-down screw and open the cover at the back of the dryer.
2. Remove the center terminal block screw.
3. Connect the neutral wire (white or center wire) of the power supply cord to the center, silver terminal block screw.

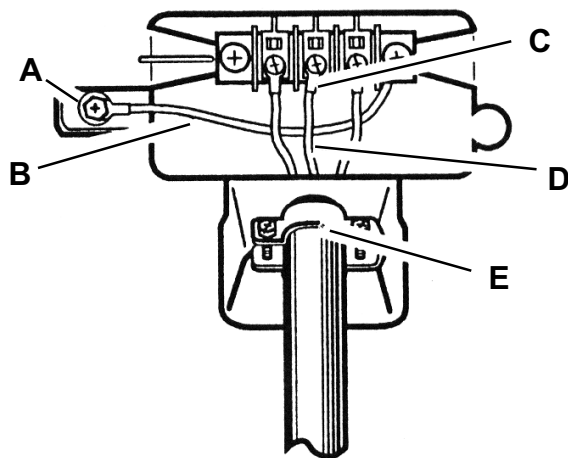

- A. External ground connector
- B. Neutral grounding wire (green/yellow)
- C. Center, silver terminal block screw
- D. Neutral wire (white or center wire)
- E. 3/4" (1.9 cm) UL-listed strain relief

4. Connect the ends of the remaining power supply wires to the left and right terminal block screws.

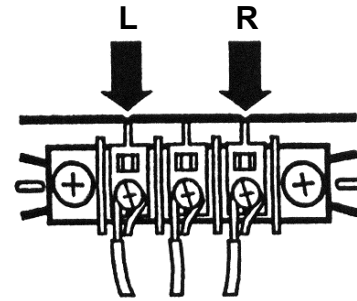

5. Check the wire connections and make sure that they are all tight.
6. Tighten the strain relief clamp screws.
7. Insert the tab of the terminal block cover into the slot of the dryer rear panel and secure the cover with its mounting screw.

3-WIRE DIRECT CONNECTION

IMPORTANT: Use this procedure only where local codes permit connecting a cabinet-ground conductor to the neutral wire.

1. Strip 3-1/2" (8.9 cm) of outer covering from the end of the cable.
2. Strip 1" (2.5 cm) of insulation from the ends of the wires. NOTE: If you are using a 3-wire cable with a ground wire, cut the bare wire even with the outer insulation.
3. Form a hook in the bare wire ends.

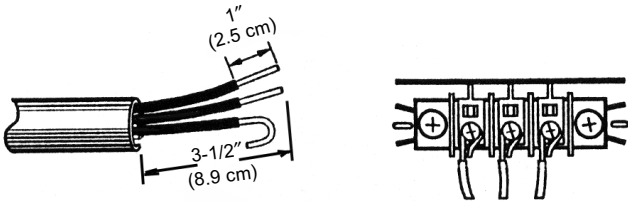

4. Remove the terminal block cover hold-down screw and open the cover at the back of the dryer.
5. Loosen or remove the center terminal block screw.

6. Connect the neutral wire (white or center wire) of the power supply cable, to the center terminal block screw.

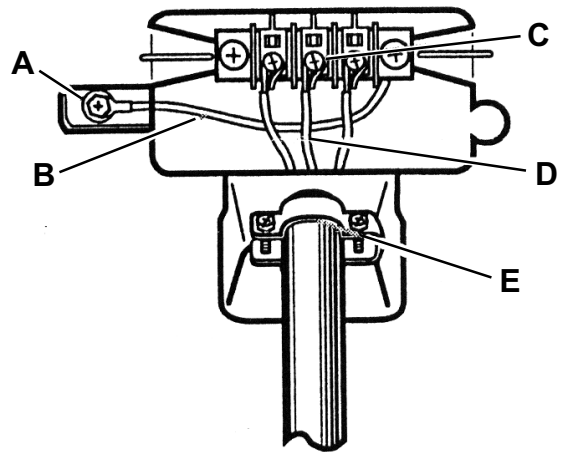

- A. External ground connector
- B. Neutral grounding wire (green/yellow)
- C. Center, silver terminal block screw
- D. Neutral wire (white or center wire)
- E. 3/4" (1.9 cm) UL-listed strain relief

7. Connect the ends of the remaining power supply wires to the left and right terminal block screws.

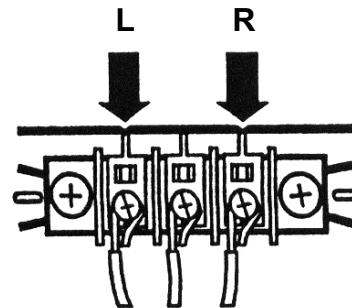

8. Check the wire connections and make sure that they are all tight.
9. Tighten the strain relief clamp screws.
10. Insert the tab of the terminal block cover into the slot of the dryer rear panel and secure the cover with its mounting screw.

OPTIONAL 3-WIRE CONNECTION

IMPORTANT: Use this procedure for connecting a direct wire or power supply cord (where local codes permit) to a cabinet-ground conductor to the neutral wire.

1. Remove the terminal block cover hold-down screw and open the cover at the back of the dryer.
2. Remove the center terminal block screw.
3. Remove the appliance ground wire (green with a yellow tracer) from the external ground connector screw. Reconnect the ground wire, and the neutral wire (white or center wire) of the power supply cord/cable, to the center (silver) terminal block screw.
4. Connect the ends of the remaining power supply wires to the left and right terminal block screws.

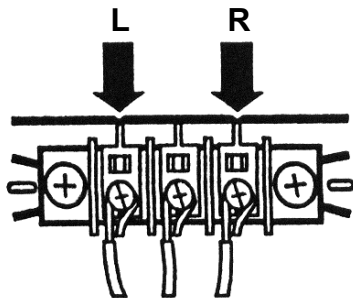

5. Check the wire connections and make sure that they are all tight.
6. Tighten the strain relief clamp screws.
7. Insert the tab of the terminal block cover into the slot of the dryer rear panel and secure the cover with its mounting screw.
8. Connect a separate copper ground wire from the external ground connector screw to an adequate ground (determined by a qualified electrician).

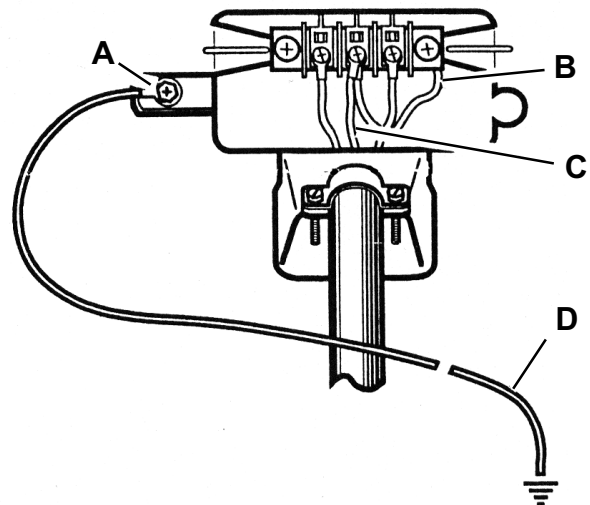

- A. External ground connector
- B. Neutral grounding wire (green/yellow)
- C. Neutral wire (white or center wire)
- D. Grounding path (determined by a qualified electrician)

ELECTRICAL REQUIREMENTS FOR GAS DRYERS

! WARNING

ELECTRICAL SHOCK HAZARD

Check with a qualified electrician if you are in doubt as to whether the appliance is properly grounded. Do not modify the power supply cord plug. If it will not fit the outlet, have a proper outlet installed by a qualified electrician.

Improper connection of the equipment grounding conductor can result in a risk of electrical shock.

Plug into a grounded 3 prong outlet.

Do not remove the ground prong.

Do not use an adapter.

Do not use an extension cord.

Failure to follow these instructions can result in death, fire, or electrical shock.

GROUNDING INSTRUCTIONS

For A Grounded Power Cord Connected Dryer

This dryer must be grounded. In the event of malfunction or breakdown, grounding will reduce the risk of electric shock by providing a path of least resistance for electric current. This dryer uses a cord having an equipment grounding conductor and a grounding plug. The plug must be plugged into an appropriate outlet that is properly installed and grounded in accordance with all local codes and ordinances.

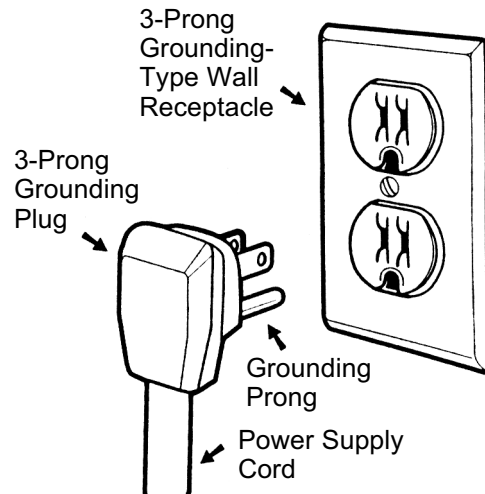

A 120 volt, 60 Hz, AC only, 15 or 20 ampere fused electrical supply is required. A time-delay fuse or circuit breaker is recommended. It is also recommended that a separate circuit serving only this appliance be provided.

GAS SUPPLY REQUIREMENTS

WARNING

EXPLOSION HAZARD

Use a new AGA or CSA approved gas supply line.

Install a shutoff valve.

Securely tighten all gas connections.

If connected to L.P. gas, have a qualified person make sure gas pressure does not exceed 13" (33 cm) water column.

Examples of a qualified person include:

Licensed heating personnel.

Authorized gas company personnel, and authorized service personnel.

Failure to do so can result in death, explosion, or fire.

GAS TYPE

Natural Gas:

This dryer is equipped for use with NATURAL GAS. It is design-certified by CSA International for L.P. (propane or butane) gases with appropriate conversion.

- Your dryer must have the correct burner for the type of gas in your home. Burner information is located on the rating plate in the door well of your dryer. If this information does not agree with the type of gas available, contact your local Whirlpool Service Center.

L.P. Gas Conversion:

Conversion must be made by a qualified technician.

No attempt shall be made to convert the appliance from the gas specified on the model/serial rating plate for use with a different gas without consulting the serving gas supplier.

OPTIONAL EXHAUST INFORMATION

WARNING



ELECTRICAL SHOCK HAZARD

Cover unused exhaust holes with the following kit:
279818 (white)
Contact your local dealer.

Failure to follow these instructions can result in death, fire, electrical shock, or serious injury.

Number Of 90° Turns Or Elbows	Type Of Vent	Box Or Louvered Hoods	Angled Hoods
0	Rigid metal	64 ft (20 m)	58 ft (17.7 m)
	Flexible metal	36 ft (11 m)	28 ft (8.5 m)
1	Rigid metal	54 ft (16.5 m)	48 ft (14.6 m)
	Flexible metal	31 ft (9.4 m)	23 ft (7.0 m)
2	Rigid metal	44 ft (13.4 m)	38 ft (11.6 m)
	Flexible metal	27 ft (8.2 m)	19 ft (5.8 m)
3	Rigid metal	35 ft (10.7 m)	29 ft (8.8 m)
	Flexible metal	25 ft (7.6 m)	17 ft (5.2 m)
4	Rigid metal	27 ft (8.2 m)	21 ft (6.4 m)
	Flexible metal	23 ft (7.0 m)	15 ft (4.6 m)

The dryer can be converted to exhaust out the right or left sides, or through the bottom.

LEVELING THE DRYER

Make sure that the floor is level with a maximum slope of 1" (2.5 cm) under the entire dryer. If the slope is greater than that stated, install the "Extended Dryer Feet Kit," **#279810**. If the dryer is not level, the clothes may not tumble properly, and the automatic cycles may not operate properly.

NOTE: Do not use the leveling legs if the dryer will be installed on a pedestal.



4 Leveling Legs (supplied in parts package)

REVERSING THE DOOR SWING

Door Reversal Kit:

Key Description

- 1 Handle Filler
- 2 Hinge Cover
- 3 Door Handle

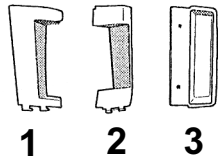

LOOSEN THE DOOR TRIM

1. Place a towel or a soft cloth on top of the dryer or work space to protect the door surface.
2. Loosen the plastic trim (1) above and below the handle filler (2).
3. Carefully pull out on the trim until it un-snaps and remove the handle filler and set it aside.

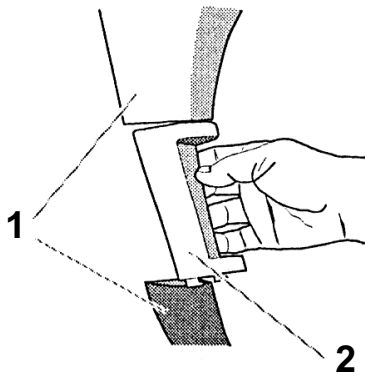

4. Loosen the plastic trim (1) above and below the hinge cover (3).
5. Carefully pull out on the trim until it un-snaps, remove the hinge cover, and set it aside.

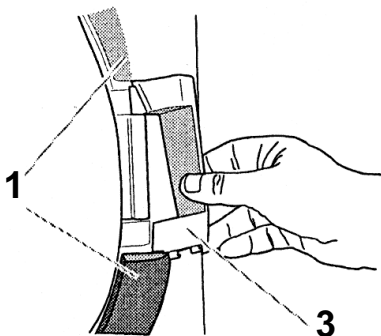

NOTE: Keep the original handle filler and hinge cover in case you decide to return the door to its original position. A new handle filler and hinge cover are provided in the door reversing kit that will be installed in a later step.

REMOVE THE DOOR

1. Open the dryer door.
2. Loosen the top keyhole screw, then remove the other four hinge screws.

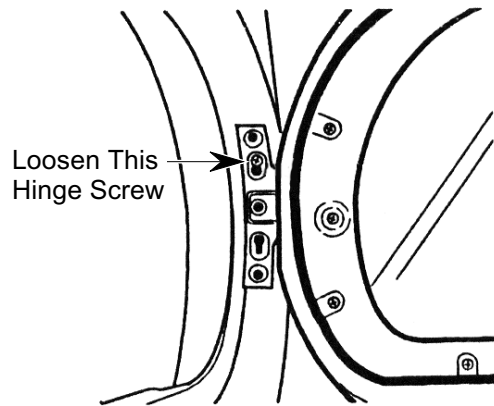

3. Lift the door from the top keyhole slot screw and place it on a padded surface with the inside door assembly facing up.
4. Remove the top keyhole slot screw and place it with the others.

Continued on the next page.

- Remove the two screws from the door handle and remove the handle by pulling straight out on it. Set the handle aside and keep it in case you ever want to restore the door swing to its original position.

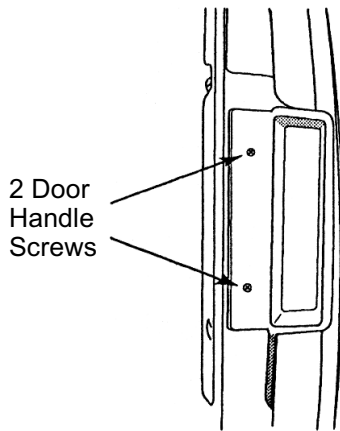

- Remove the six screws that are indicated by the arrows, shown in the illustration. **Do not remove any of the other screws.**

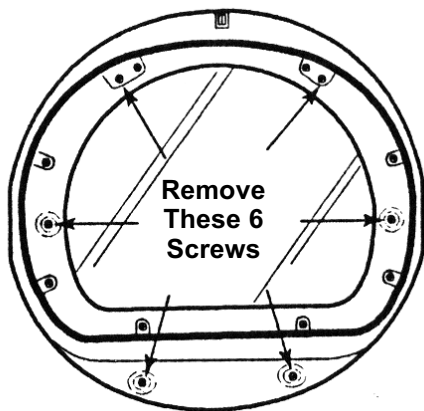

- Lift the inner door assembly off of the outer door assembly and set the outer door assembly aside.

REVERSE THE HINGE & HINGE BRACKET

- Place the inner door, screw head side facing up, on the padded work surface.
- Remove the four door hinge screws.

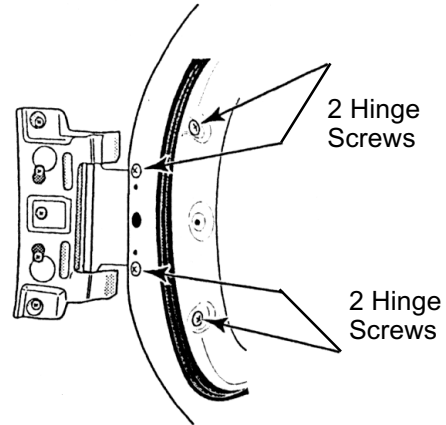

- Remove the two screws from the handle bracket and remove the bracket.

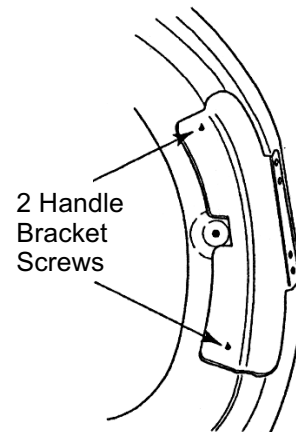

- Mount the hinge to the other side of the door with the four screws you removed in step 2.
- Mount the handle bracket to the other side of the door with the two screws you removed in step 3.
- Set the inner door assembly aside.

REINSTALL THE DOOR

1. If necessary, clean both sides of the door glass before reassembling it.
2. Place the inner door assembly into the outer door assembly and align the hinge in the opening on the side. Fit the inside door assembly edge completely inside the outer door assembly.
3. Loosely install the six screws in the door. Once all of the screws are loosely installed, and the edges of the door are properly aligned, tighten the screws securely.

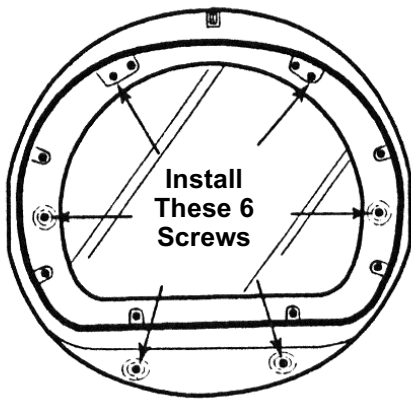

4. Insert the new handle into the side opening of the door. Make sure that the handle seats all the way in the opening, and that the holes are all aligned properly, then mount the handle with two screws.
5. Using a small screwdriver, remove the hole plugs in the door opening of the dryer, and install them in the former screw holes in the other side of the dryer. Be careful not to damage the finish.

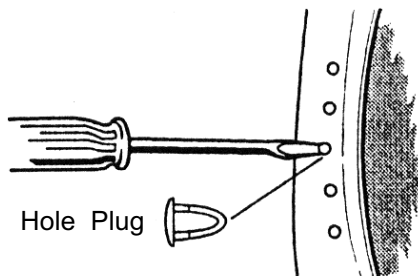

6. Install a screw halfway into the second hole from the top.

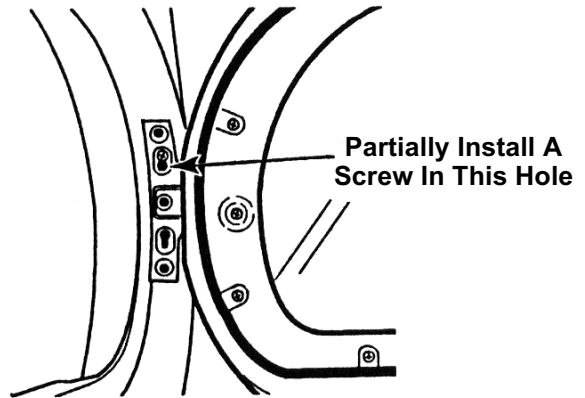

7. Hang the door hinge on the screw you just installed, then install the remaining four screws in their holes, and tighten the loose screw securely. Make sure that all five hinge screws are secure.

INSTALL THE NEW HANDLE FILLER AND HINGE COVER

1. Using the new handle filler that was provided with the reversing kit, hook the top of the handle filler onto the loosened upper door trim, and snap the joined pieces into place.
2. Hook the bottom of the handle filler onto the lower door trim and snap it into place.
3. Repeat steps 1 and 2 to install the hinge cover on the opposite side of the door.
4. Close the door and make sure that it latches securely.

INSTALLING THE OPTIONAL PEDESTAL

! WARNING

EXCESSIVE WEIGHT HAZARD

Use two or more people to move and install pedestal.

Failure to do so can result in back or other injury.

1. Open the pedestal drawer and remove the envelope taped inside. This envelope contains four #12 x 5/8" (1.6 cm) hex-head sheet metal screws that will be used in the assembly.
2. Remove the phillips screw from each drawer slide and remove the drawer. Set the drawer and two screws aside.

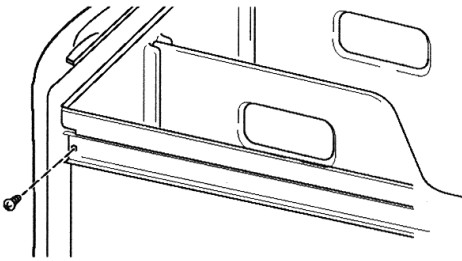

3. Push the slides back into the pedestal.
4. If installed, remove the feet from the dryer. Do not install the feet that came with a new dryer.

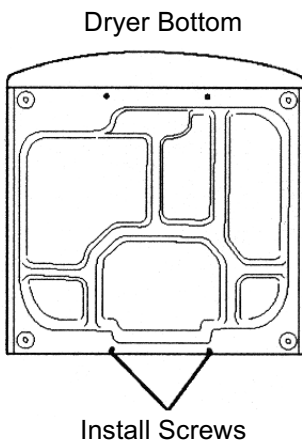

5. Partially install the two lower #12 x 5/8" (1.6 cm) hex-head sheet metal screws, leaving a space of about 3/8" (1 cm) between the screw head and the bottom of the dryer.

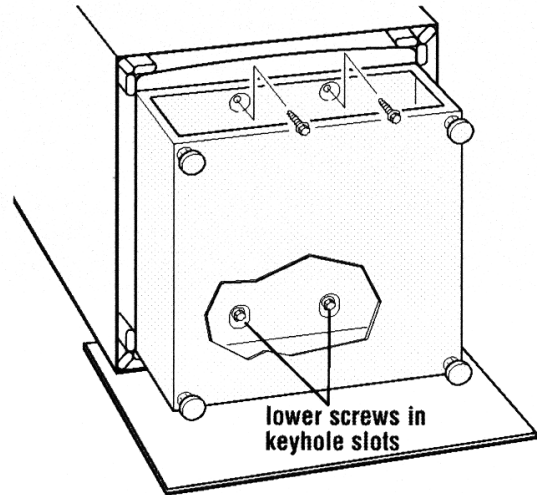

6. Move the pedestal against the dryer bottom. Slide the pedestal's keyhole slots over the two lower partially installed screws.
7. Lift the pedestal toward the front of the dryer and partially install the two remaining hex-head sheet metal screws.
8. Align the sides of the pedestal so that they are even with the sides of the dryer. Reach inside the pedestal drawer opening and securely tighten all four pedestal screws.
9. Tip the dryer and pedestal assembly back to the upright position and remove the protective cardboard.
10. Position the dryer close to its final location.
11. If the dryer is still in its packaging, follow the instructions on the packaging and remove it.
12. Follow the Installation Instructions that were supplied with the dryer, and finish installing or reinstalling it.

13. Place a spirit level on the top of the pedestal. Use a 1/4" (6.4 mm) hex-head ratchet or open-end wrench, and adjust the four feet, to level the dryer from side-to-side and front-to-back.

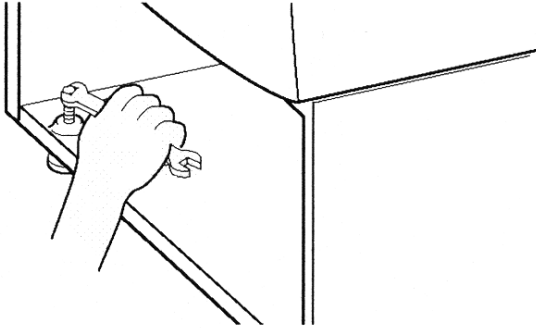

14. When the dryer is level, use a 9/16" (14.3 mm) open-end wrench to securely tighten all four feet locknuts against the pedestal. The locknuts must be tightened.

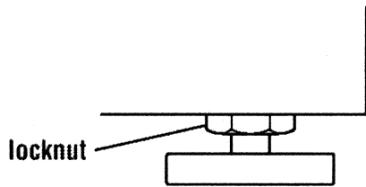

15. Pull both drawer slides out and reassemble the drawer to the drawer slides with the two phillips screws.

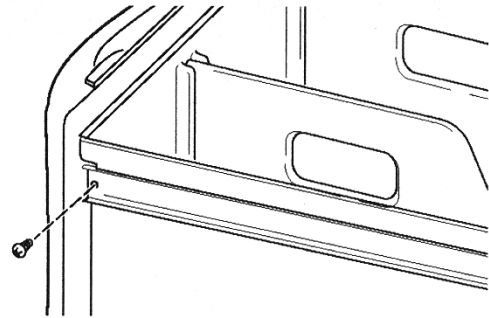

16. Install the dividers and close the drawer.

OPTIONAL STACK KIT (#8519492)

An optional stack kit will be made available to mount the dryer on top of the matching Duet washer. The Kit contains the following:

<u>Qty</u>	<u>Description</u>	<u>Part Number</u>
2	Spacer Pad	#8519491
2	Mounting Bracket	#8529746
4	Hex-Head Screw	#3400804
1	Installation Instructions	#8519474

The kit parts will be attached to the washer so that the dryer can be mounted on top. Use the instructions that are provided with the kit to install the parts.

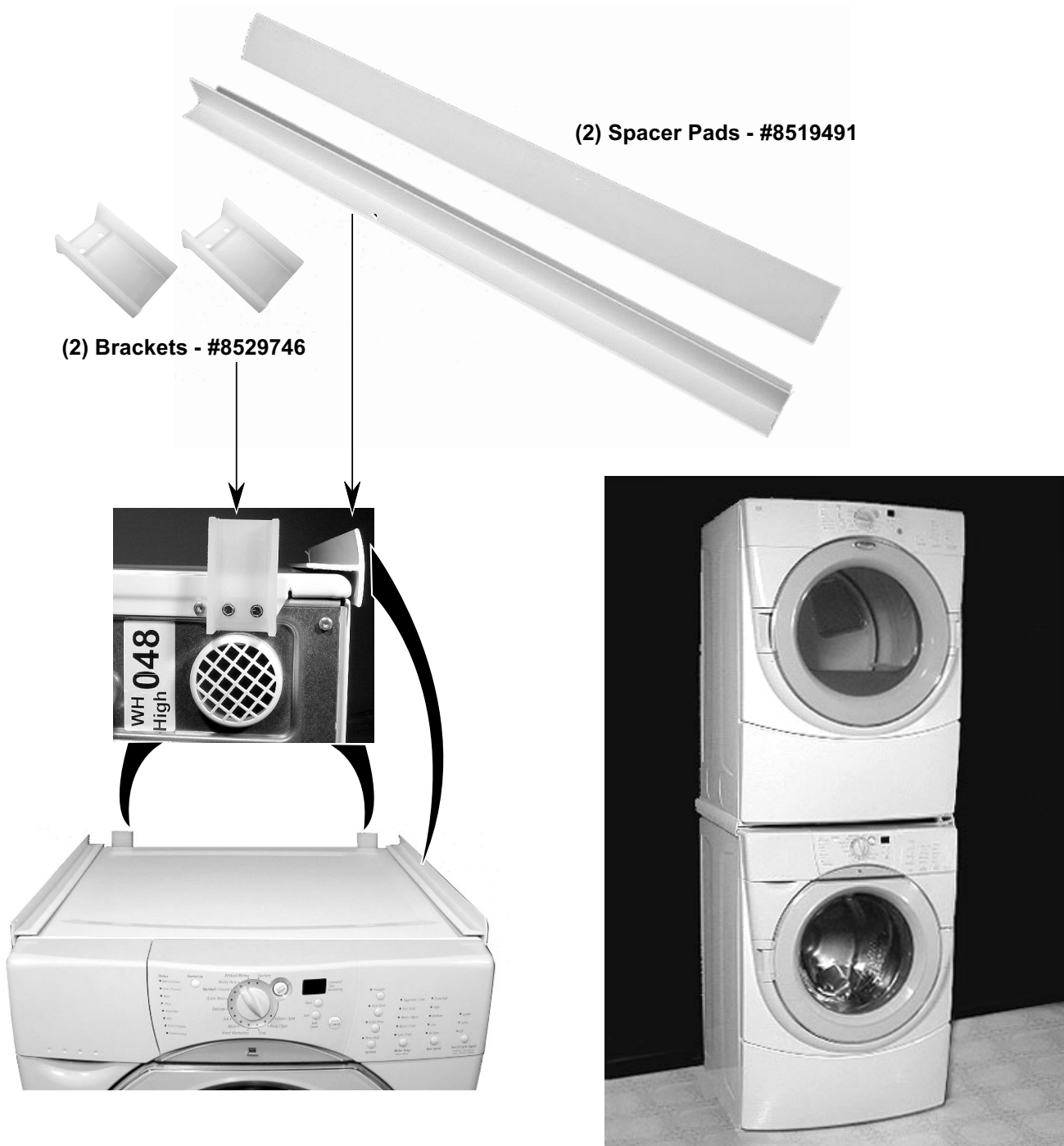

PRODUCT OPERATION

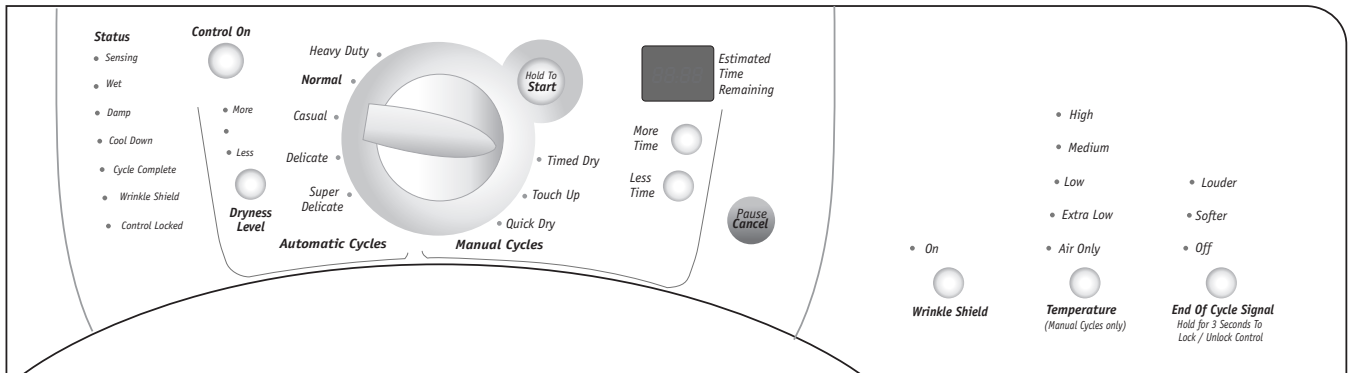



WARNING



EXPLOSION HAZARD

Keep flammable materials and vapors, such as gasoline, away from dryer.

Do not dry anything that has ever had anything flammable on it (even after washing).

Failure to follow these instructions can result in death, explosion, or fire.



FIRE HAZARD

No washer can completely remove oil.

Do not dry anything that has ever had any type of oil on it (including cooking oils).

Items containing foam, rubber, or plastic must be dried on a clothesline or by using an Air Cycle.

Failure to follow these instructions can result in death or fire.

STARTING THE DRYER

The following is a guide to starting the dryer. Please refer to specific sections of the Owner's Manual for more detailed information.

1. Clean the lint screen before or after each cycle.
2. Place the laundry into the dryer and close the door.
3. Rotate the dial to select either an *Automatic* or *Manual Cycle*, then press the *Control On* button. The preset settings and drying time for the cycle chosen will be displayed.

To use an *Automatic Cycle*:

- Point the dial to an *Automatic Cycle*.
- Select the *Dryness Level* to adjust how dry you want the clothes. The time displayed is an estimated length of the cycle based on the dryness level selected. As the cycle runs, the control senses the dryness of the load and adjusts the time automatically for the selected dryness level.

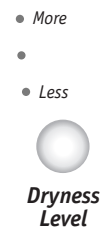

NOTE: Time is not adjustable for *Automatic Cycles*. Pressing the *More Time* or *Less Time* buttons will cause a triple beep, indicating that the time cannot be changed.

- Press the *Wrinkle Shield* feature button, if this option is desired.
- Press the *End Of Cycle Signal* button to set the signal volume to the desired level.
- Press and hold the *Hold To Start* button until the dryer starts (about 1 second).

Once an *Automatic Cycle* has started, the *Wrinkle Shield* feature, and the *End Of Cycle Signal* level can be adjusted. Press the *Pause/Cancel* button twice to stop the dryer and clear the settings, allowing you to select another cycle and dryness level.

To use a **Manual Cycle**:

- Rotate the dial to select a *Manual Cycle*.
- Press *More Time* or *Less Time* until the desired drying time is displayed. Tap *More Time* or *Less Time* and the time will change by 1 minute intervals. Press and hold *More Time* or *Less Time* and the time will change by 5 minute intervals.

NOTE: The *More Time* or *Less Time* feature can only be used with *Manual Cycles*.

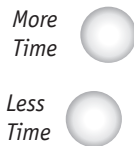

- Press the *Temperature* button until the desired temperature is indicated.

NOTE: Pressing the *Dryness Level* button will cause the triple beep, indicating that this option is not selectable. Also, a dryness level is not indicated.

The initial time displayed is the actual drying time. As the cycle runs, the control senses the dryness of the load, and adjusts the time automatically for the selected dryness level.

- Press and release the *Wrinkle Shield* button if this option is desired.
- Press the *End Of Cycle Signal* button to set the volume to the desired level.
- Press and hold the *Hold To Start* button until the dryer starts (about 1 second).

During a *Manual Cycle*, you can change the settings for *Time*, *Temperature*, the *Wrinkle Shield* feature, and the *End of Cycle Signal* functions. Press the *Pause/Cancel* button twice to stop the dryer and clear the settings, allowing you to select another cycle.

STOPPING THE DRYER

To stop the dryer at any time:

- Press the *Pause/Cancel* button twice.

PAUSING OR RESTARTING

To pause the dryer at anytime:

- Open the door or press the *Pause/Cancel* button once.

To restart the dryer:

- Close the door and press and hold the *Hold To Start* button until the dryer starts.

NOTE: Drying will continue from where the cycle was interrupted if you close the door and press *Start* within 5 minutes. If the cycle is interrupted for more than 5 minutes, the dryer will shut off. Select the new cycle settings before restarting the dryer.

CONTROL LOCKED

This feature allows you to lock your settings to prevent unintended use of the dryer. You can also use this feature to prevent unintended cycle changes during dryer operation.

To enable the **Control Locked** feature:

Press and hold the *End Of Cycle Signal* button for 3 seconds. The control is locked when a single beep is heard and the *Control Locked* status light is on.

- When the dryer is off, it is not necessary to press the *Control On* button before activating the *Control Locked* feature.

To unlock the **Control Locked** feature:

Press and hold the *End Of Cycle Signal* button for 3 seconds to turn this feature off.

NOTE: When the dryer is running and *Control Locked* is on, the dryer can be stopped by pressing the *Pause/Cancel* button, but cannot be restarted until the control is unlocked.

STATUS LIGHTS

The *Status* indicator lights show the progress of the dryer. Each of the lights indicate as follows:

Status

- *Sensing*
- *Wet*
- *Damp*
- *Cool Down*
- *Cycle Complete*
- *Wrinkle Shield*
- *Control Locked*

Sensing

When the dryer is first turned on, the *Sensing* light glows until a wet item is detected.

- In an *Automatic Cycle*, if a wet item has not been detected within 10 minutes, the *Sensing* light will turn off, and the dryer will shut down.
- In a *Manual Cycle*, if a wet item is not detected after 10 minutes, the *Wet* light turns on, and the selected cycle continues.

Wet

The *Wet* light will turn on when a wet item has been detected in the dryer. The *Wet* light will remain on until:

- The damp dry point is reached in an *Automatic Cycle*.
- The dryer enters the cool down period in a *Manual Cycle*.

Damp

The *Damp* light indicates that the load has reached a damp dry level.

NOTE: The *Damp* light is not used with *Manual Cycles*.

Cool Down

The *Cool Down* light glows during the cool down part of the cycle. Laundry is cooling down for ease in handling.

Cycle Complete

This light glows when a drying cycle is finished. If the *Wrinkle Shield* feature has been selected, the *Wrinkle Shield* feature indicator light will also be on.

The *Cycle Complete* light turns off 1 hour after the end of a drying cycle (including the *Wrinkle Shield* cycle of 2 hours), when *Pause/Cancel* is pressed, or when the door is opened.

Wrinkle Shield Feature

The *Wrinkle Shield* feature light glows when this option is selected. This indicator stays on with the *Cycle Complete* light.

Control Locked

The *Control Locked* light glows when this option is enabled.

Indicator Lights

Other indicator lights on the control panel, show *Cycle*, *Temperature*, and *End Of Cycle Signal* settings that are selected.

The time display will indicate the estimated or actual time remaining in a cycle.

CYCLE DESCRIPTIONS

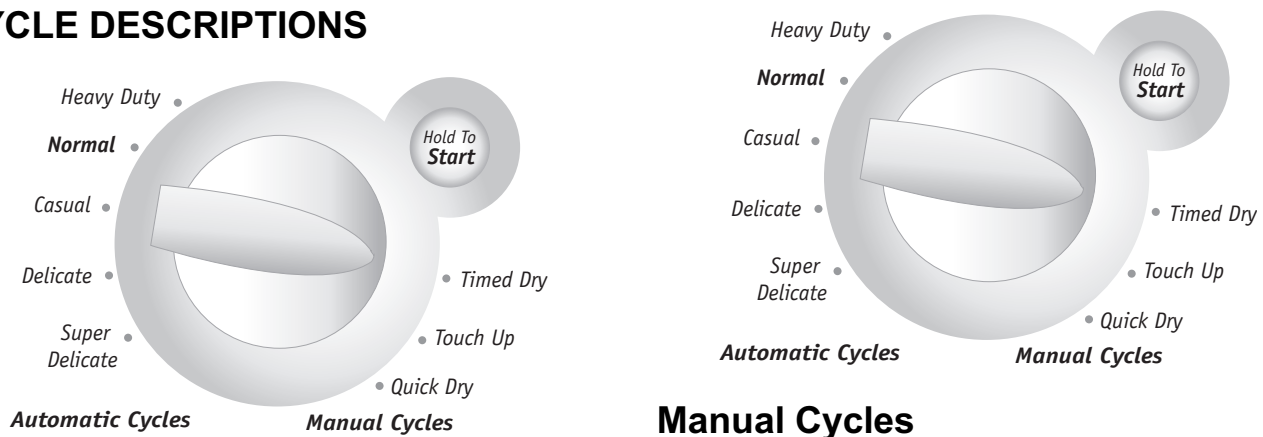

Automatic Cycles

The *Automatic Cycles* allow the user to match a cycle to the type of load to be dried. A sensor detects the moisture in the clothes, and automatically adjusts the drying time for optimal drying.

Heavy Duty

Uses high heat for heavy fabrics, such as cotton towels or bedspreads.

Normal

Uses medium heat for drying sturdy fabrics, such as work clothes.

Casual

Uses medium heat for no-iron fabrics, such as sport shirts, casual business clothes, and permanent press.

Delicate

Uses low heat for drying synthetic fabrics, washable knit fabrics, and no-iron finishes.

Super Delicate

Uses extra-low heat for drying items such as lingerie, exercise wear, or sheer curtains.

Manual Cycles

The *Manual Cycles* allow the user to select a specific amount of drying time and a drying temperature. When a *Manual Cycle* is selected, the *Estimated Time Remaining* display shows the actual time remaining in the cycle. The actual time in the cycle can be changed by pressing *More Time* or *Less Time*.

Timed Dry

Use this cycle to extend drying time when items are still damp after an *Automatic Cycle*.

Touch Up

Use this cycle to remove wrinkles from items, such as clothes packed in a suitcase, or items wrinkled from being left in the dryer too long.

Quick Dry

Use this cycle for drying small loads or loads that need a short drying time.

ADDITIONAL FEATURES

Wrinkle Shield Feature

- On



Wrinkle Shield

Prevents wrinkles that form when the dryer is not unloaded immediately at the end of a cycle.

- Press the *Wrinkle Shield* feature to get up to 2 hours of heat-free, periodic tumbling at the end of a cycle.
- Stop at any time by pressing the *Wrinkle Shield* feature button, or by opening the dryer door.

- For the *Casual Cycle*, the *Wrinkle Shield* feature is preset to On. The other *Automatic Cycles* will retain the *Wrinkle Shield* feature setting.

NOTE: If you do not select the *Wrinkle Shield* feature, the dryer stops after cool down.

Temperature

Use the *Temperature* settings to select temperatures for the *Manual Cycles*. Press the *Temperature* button until the desired temperature setting is indicated on the display. *Temperature* settings cannot be used with the *Automatic Cycles*.

- *High*
- *Medium*
- *Low*
- *Extra Low*
- *Air Only*



Temperature
(Manual Cycles only)

Air Only

Use for items that require drying without heat, such as rubber, plastic and heat-sensitive fabrics. NOTE: The *Air Only* feature will not operate with *Automatic Cycles*.

End of Cycle Signal

The *End of Cycle Signal* produces an audible sound when the drying cycle is finished. Promptly removing clothes at the end of the cycle reduces wrinkling.

- *Louder*
- *Softer*
- *Off*



End Of Cycle Signal
Hold for 3 Seconds To
Lock / Unlock Control

Press the *End of Cycle Signal* to adjust the sound level or turn off the signal.

NOTE: When *Wrinkle Shield* feature is selected and the *End of Cycle Signal* is on, an audible sound will be heard every 5 minutes until the clothes are removed, or until the *Wrinkle Shield* feature is finished.

— NOTES —

COMPONENT ACCESS

This section instructs you on how to service each component inside the Gas and Electric Dryers. The components and their locations are shown below.

! WARNING

ELECTRICAL SHOCK HAZARD

**Disconnect power before servicing.
Replace all panels before operating.
Failure to do so can result in death or electrical shock.**

FIRE HAZARD

**Shut off gas supply line valve before servicing.
Check all gas line connections and replace all panels before operating.
Failure to do so could result in explosion, fire, or other injury.**

COMPONENT LOCATIONS

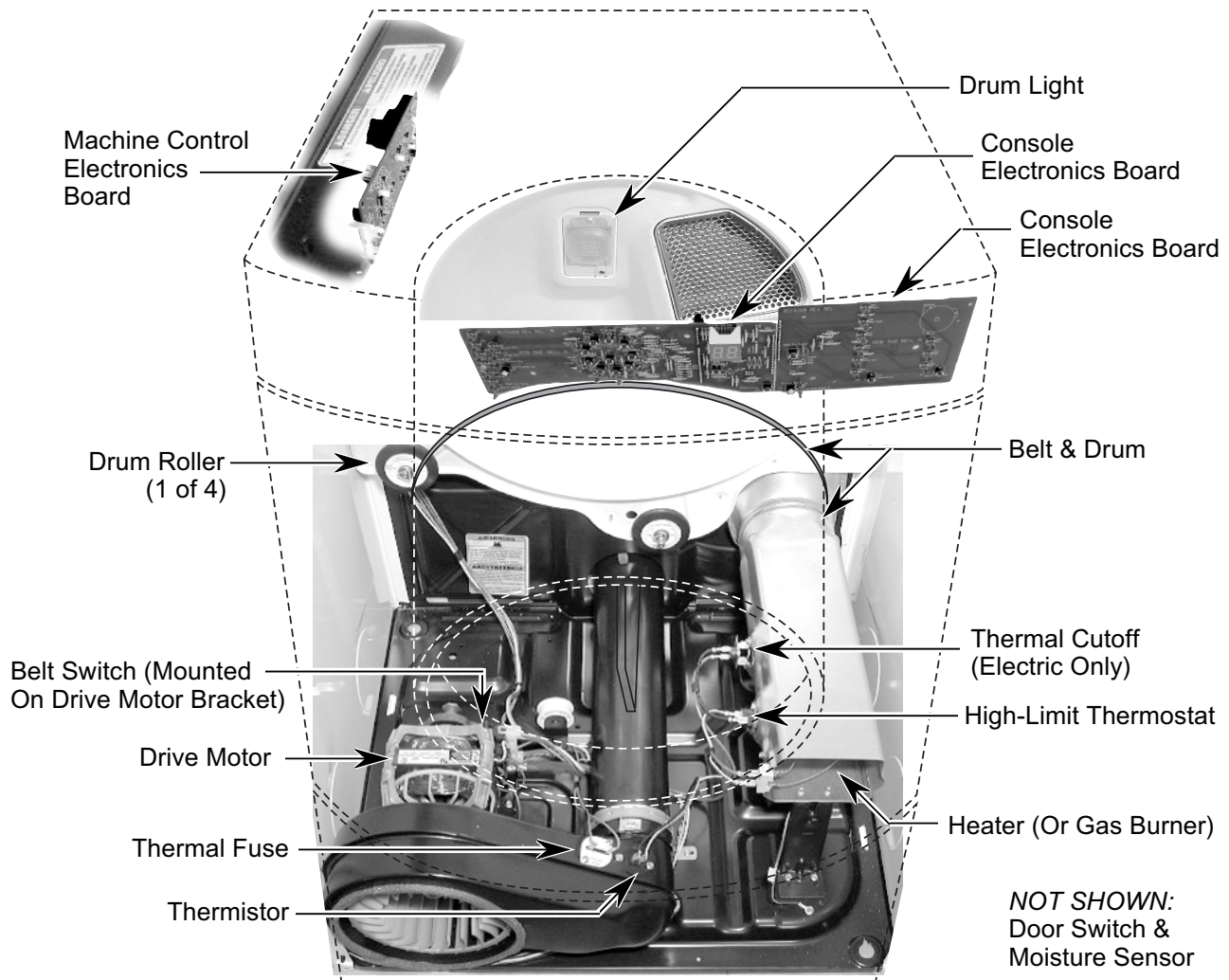

REMOVING THE MACHINE CONTROL ELECTRONICS BOARD

NOTE: Sharp edges may be present.

1. Turn off the gas to the dryer and disconnect the electrical power.
2. Pull the dryer away from the wall far enough to access the back.
3. Remove the three hex-head screws from the rear flange of the dryer's top cover. NOTE: The top cover screws have nylon flat washers on them. Be sure to use these screws when you reinstall the top cover.



4. Lift the rear of the top cover and slide it back so the tabs clear the catches on the bracket, and remove the cover from the unit. NOTE: Make sure that the tabs slide under the bracket catches when you reinstall the top cover.

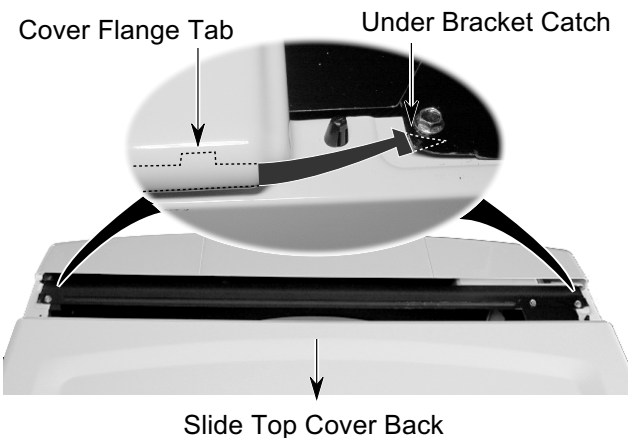

5. Remove the three screws from the machine control electronics board bracket and pull the bracket away from the side of the dryer so you can access the connectors.

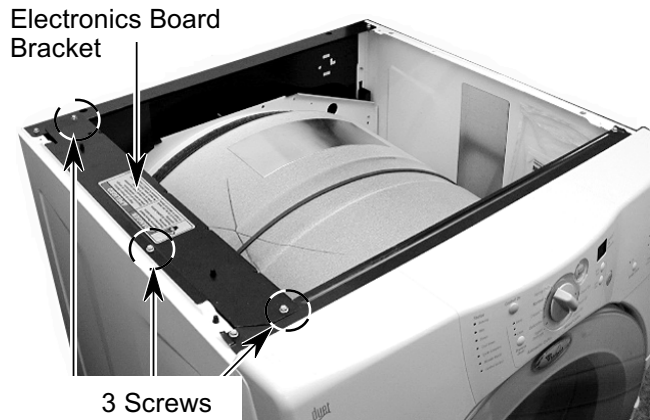

6. Disconnect the 3-wire connector from the main harness.
7. Remove the following connectors and wires from the board:
5-wire connector at P1.
Red and black wires at relay K1.
7-wire connector at P2.
Ribbon cables at P3 and P4.

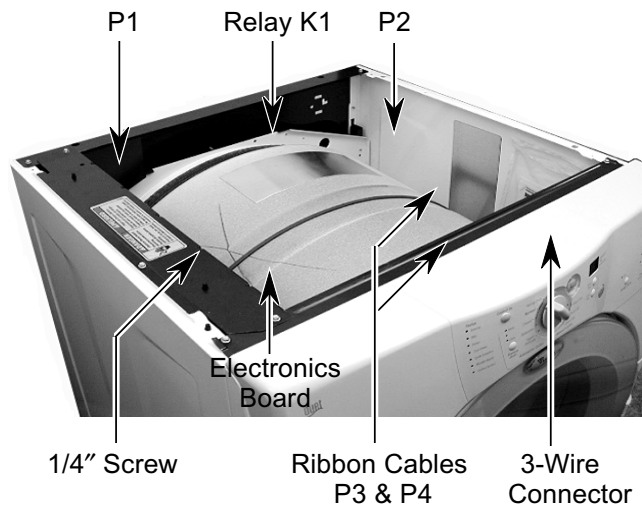

8. Remove the 1/4" hex-head screw from the electronics board.

9. Squeeze the two board supports and remove the electronics board from the bracket.

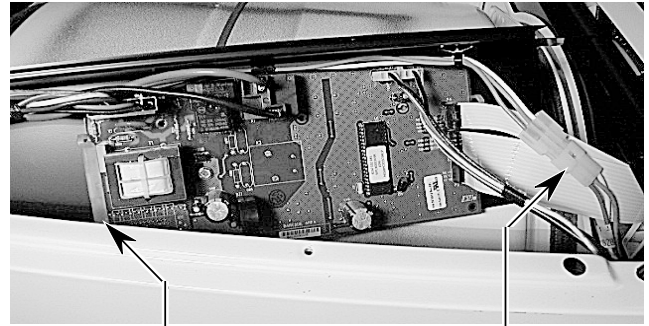

Squeeze Ends Of Supports To Remove Board

REMOVING THE CONSOLE & THE TOUCHPAD SUBASSEMBLY

NOTE: Sharp edges may be present.

1. Turn off the gas to the dryer and disconnect the electrical power.
2. Pull the dryer away from the wall and remove the top cover (see steps 3 and 4 on page 4-2 for the procedure).
3. Remove the three screws from the machine control electronics board bracket, and tip the bracket assembly inside the dryer (see step 5 on page 4-2 for the procedure).
4. Disconnect the ends of the two ribbon cables from the machine control electronics board connectors P3 and P4.

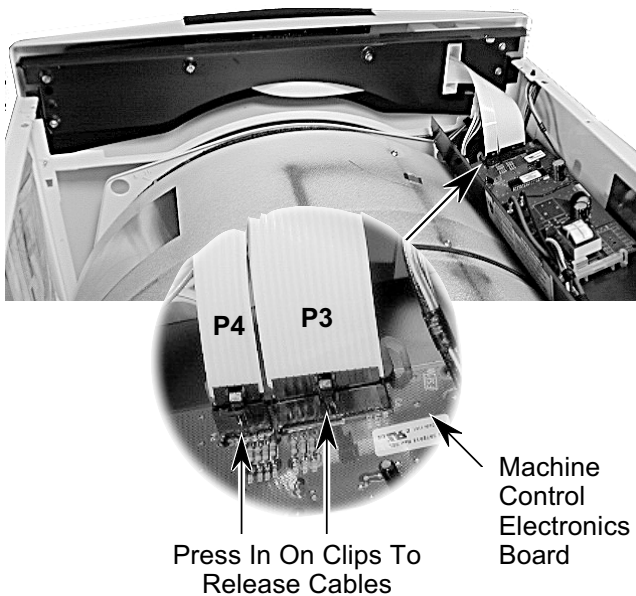

5. Remove the two screws from the console bracket.



6. Open the door and pull out on the bottom of the console to release the locking tabs from the door panel.



7. Lift the console straight up until the brackets are free of the left and right side panel flanges and remove the console.

Viewed From Back Of Console

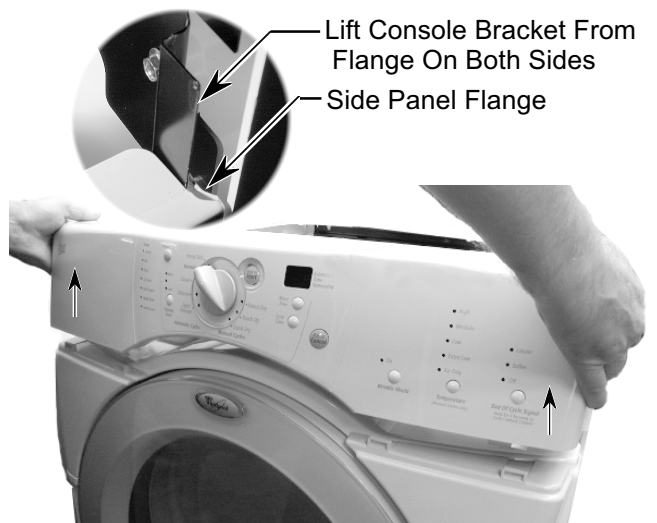

8. Place the console assembly on a padded work surface with the bracket side facing up, as shown in step 9.

9. Remove the four hex-head screws from the console bracket and remove the bracket.

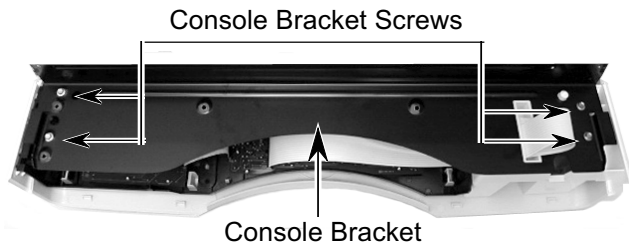

10. Remove the selector knob.
11. Remove the touchpad subassembly from the console by unsnapping the six catches. Use your thumb or a screwdriver.

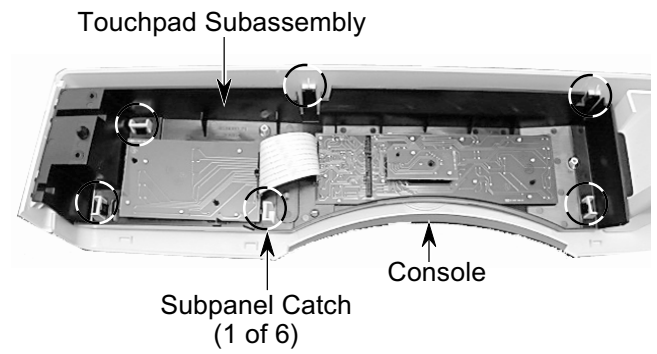
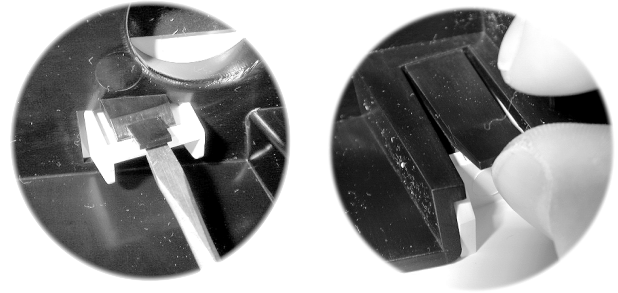

REMOVING THE DOOR SWITCH

NOTE: Sharp edges may be present.

1. Turn off the gas to the dryer and disconnect the electrical power.
2. Pull the dryer away from the wall and remove the top cover (see steps 3 and 4 on page 4-2 for the procedure).
3. Remove the console (see page 4-4 for the procedure). Tip the console back and lay it on a padded surface.
4. Push the wire holder out of the chassis hole.
5. Pry the door switch out of the cutout. If necessary, press a screwdriver blade against the locking arms on each side of the door switch, (from behind the cutout), and push the switch out.
6. Disconnect the wires from the door switch terminals.

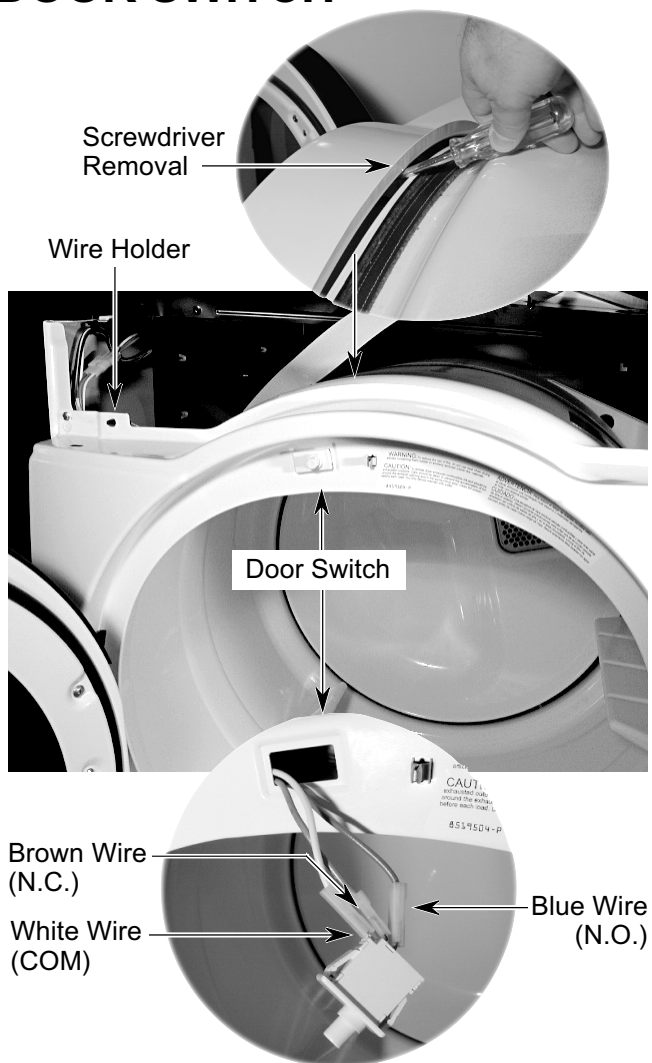

REMOVING THE THERMAL FUSE, THERMISTOR, DRIVE MOTOR, & BELT SWITCH

NOTE: Sharp edges may be present.

1. Turn off the gas to the dryer and disconnect the electrical power.
2. Open the dryer door and remove the lint filter screen, then close the door.

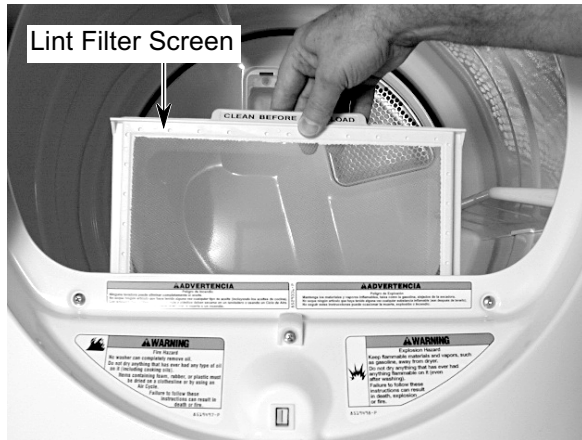

3. Remove the two hex-head screws from the bottom flange of the toe panel. Pull the panel out at the bottom, pull down, and remove the panel.

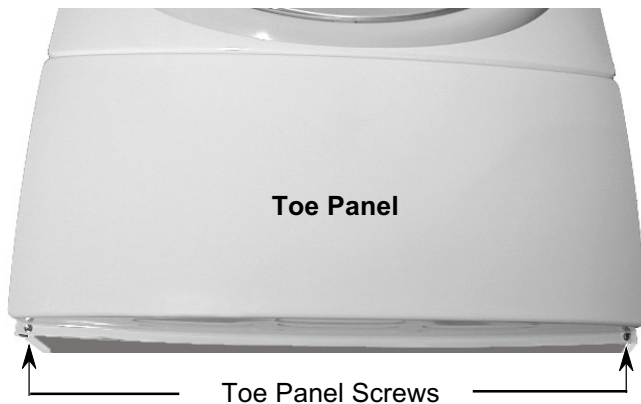

4. Remove the hex-head screw from the lint duct bracket and remove the bracket.

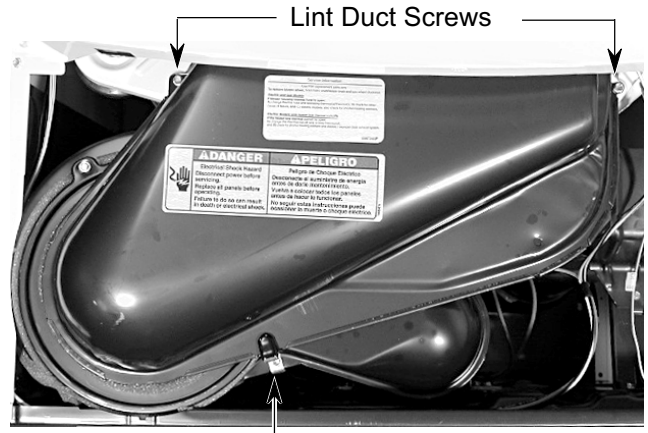

5. Remove the two hex-head screws from the lint duct and remove the duct.
6. **To remove the thermal fuse or thermistor:**
 - a) Remove the two wires from the terminals.
 - b) Remove the two hex-head screws.

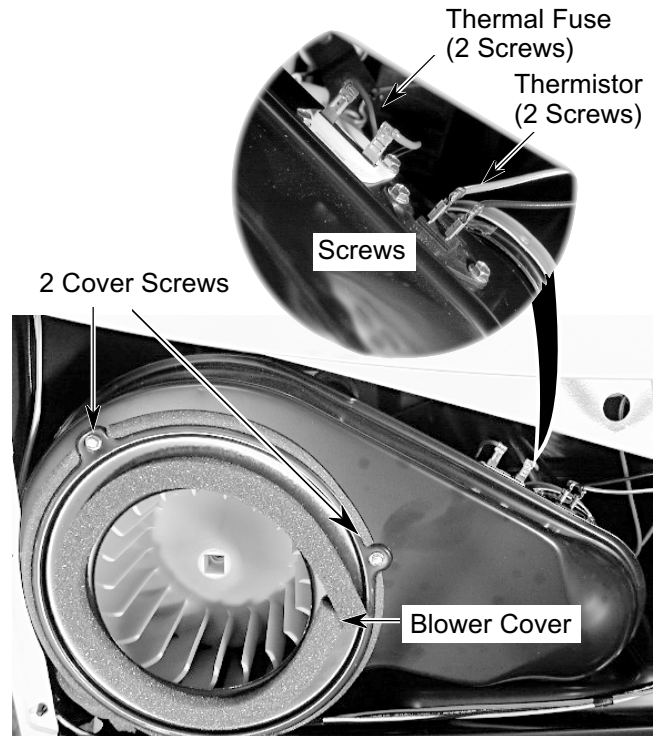

Continued on the next page.

7. **To remove the drive motor:**

- a) Remove the wires from the thermal fuse and thermistor terminals (see the photo at the bottom of the previous page).
- b) Remove the two hex-head screws from the blower cover (see the previous page) and remove the cover.
- c) Reach around to the back of the drive motor and attach a 7/8" open-end wrench over the hex-end of the motor shaft, and a ratchet with a 1/2" drive on the blower wheel hub.
- d) Turn the blower wheel clockwise (shown by the "REMOVE" arrow that is embossed on the front of the wheel) and remove the wheel from the motor shaft.

- e) Remove the three hex-head screws from the blower housing and remove it.

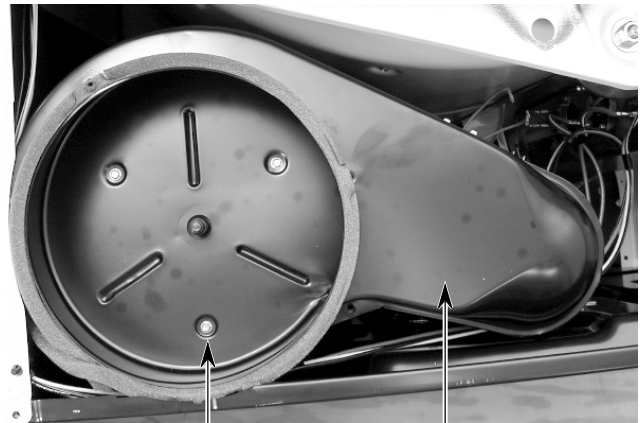

Housing Screw
(1 of 3)

Blower Housing

- f) Reach around behind the drive motor and push the idler wheel arm to the left, then remove the tension, and remove the belt from the idler pulley.

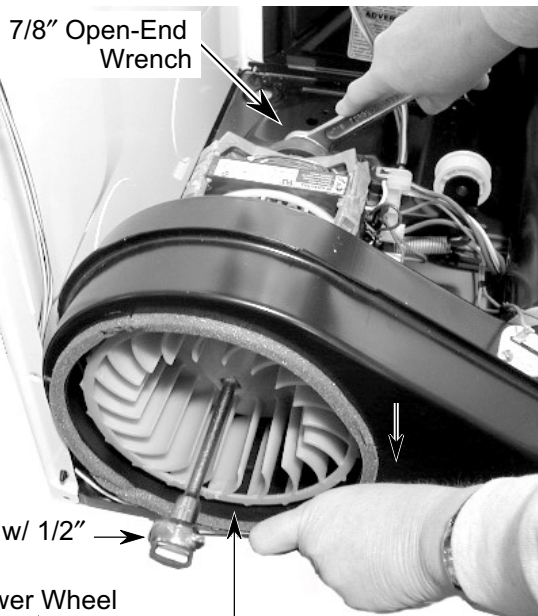

7/8" Open-End
Wrench

Ratchet w/ 1/2"
Drive

Blower Wheel

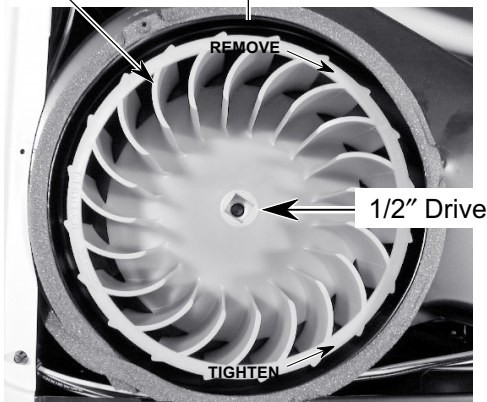

REMOVE

1/2" Drive

TIGHTEN

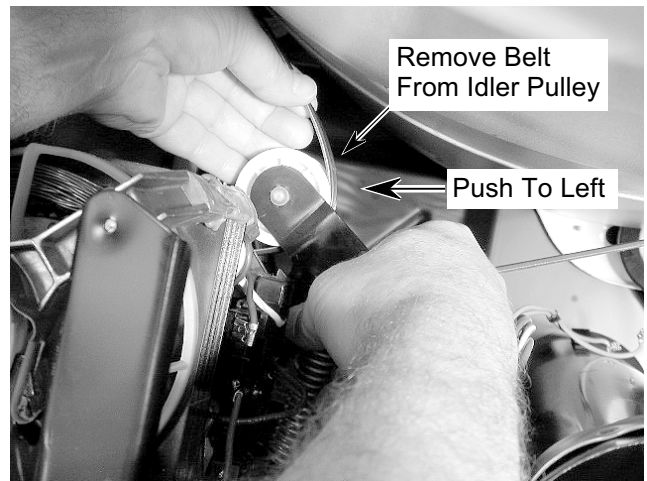

Remove Belt
From Idler Pulley

Push To Left

- g) Lift the top locking tab of the motor harness plug and pull the top pins away from the motor connector, then release the bottom tab, and remove the plug.

Top Locking Tab Motor Harness Plug

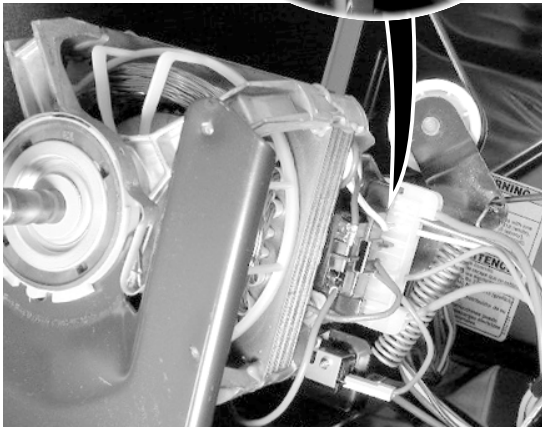
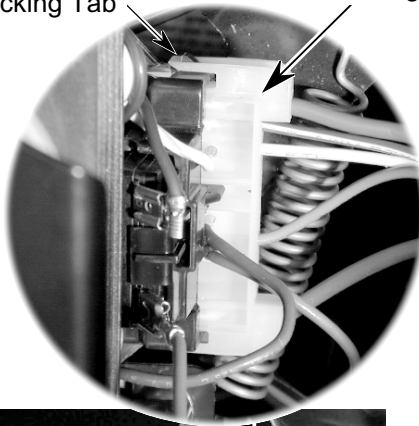

- h) Remove the two hex washer-head mounting screws from the drive motor, then lift the right side of the motor slightly, pull the two tabs on the left side out of the chassis slots, and remove the drive motor.



8. **To remove the belt switch:**

- a) If not already done, remove the drive motor (see step 7 on page 4-8).
 b) Remove the 3/8" hex shoulder-washer screw from the idler pulley assembly and remove the assembly.

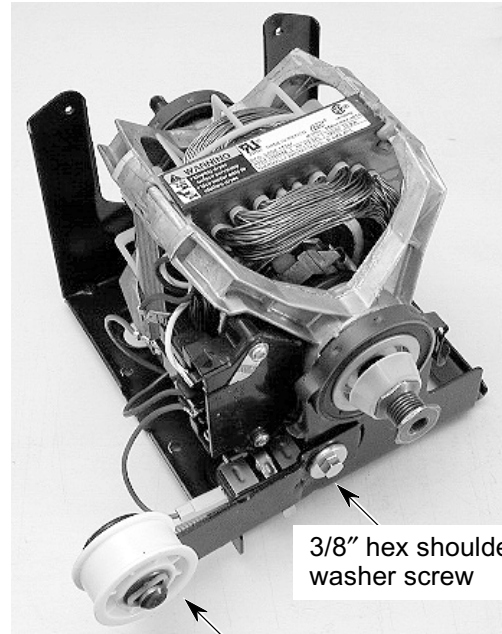

Idler Pulley Assembly

- c) Remove the two screws from the belt switch and remove it from the motor.

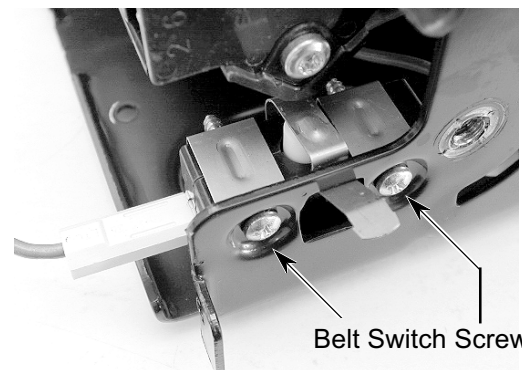

- d) Disconnect the blue wires from the belt switch terminals.

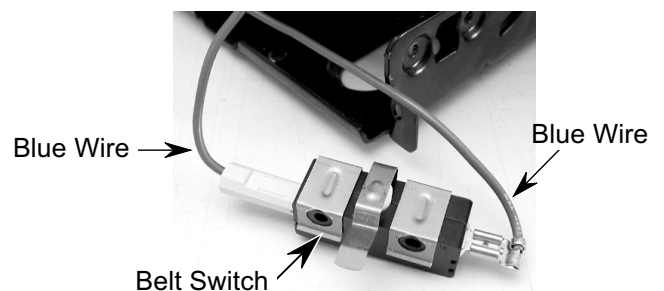

REMOVING THE HEATER, THE HIGH-LIMIT THERMOSTAT, & THERMAL CUTOFF

NOTE: Sharp edges may be present.

1. Turn off the gas to the dryer and disconnect the electrical power.
2. Remove the two hex-head screws from the bottom flange of the toe panel. Pull the panel out at the bottom, pull down, and remove the panel.

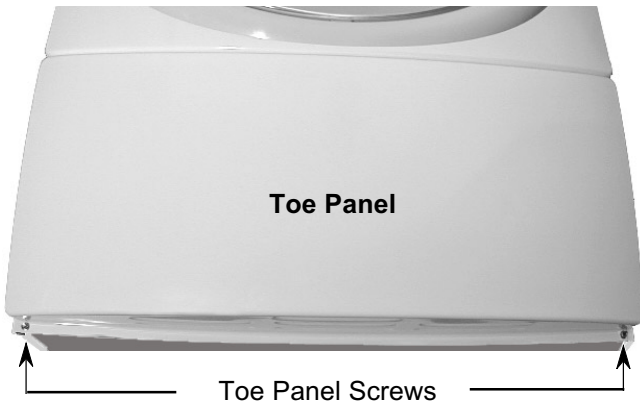

3. Remove the hex-head screw from the heater shield and remove the shield.

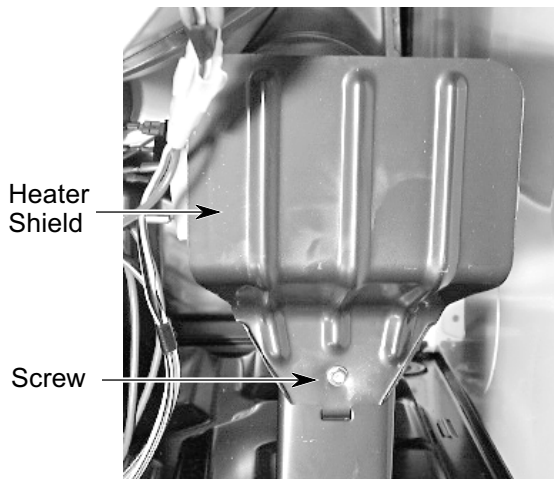

4. To remove the heater:

- a) Remove the two wires from the terminal block (see bottom photo).
- b) Remove the hex-head screw from the heater housing, and slide the heater out of the duct.



5. To remove the high-limit thermostat or the thermal cutoff:

- a) Disconnect the wires from the high-limit thermostat or the thermal cutoff.
- b) Remove the two hex-head screws.

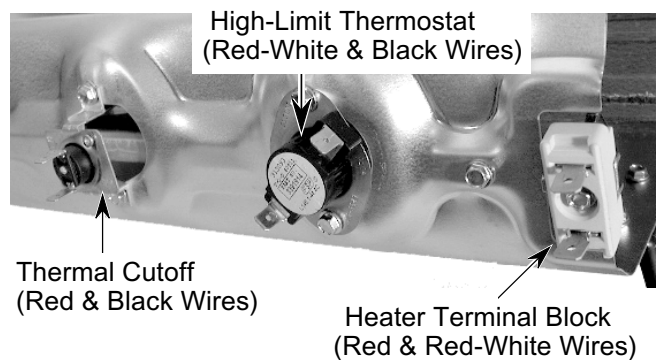

REMOVING THE BELT, DRUM, & ROLLERS

NOTE: Sharp edges may be present.

1. Turn off the gas to the dryer and disconnect the electrical power.
2. Pull the dryer away from the wall and remove the top cover (see steps 3 and 4 on page 4-2 for the procedure).
3. Remove the console (see page 4-4 for the procedure).
4. Remove the lint duct (see steps 2 through 5 on page 4-7 for the procedure).
5. Reach around behind the drive motor and push the idler wheel arm to the left, then remove the tension, and remove the belt from the idler pulley.

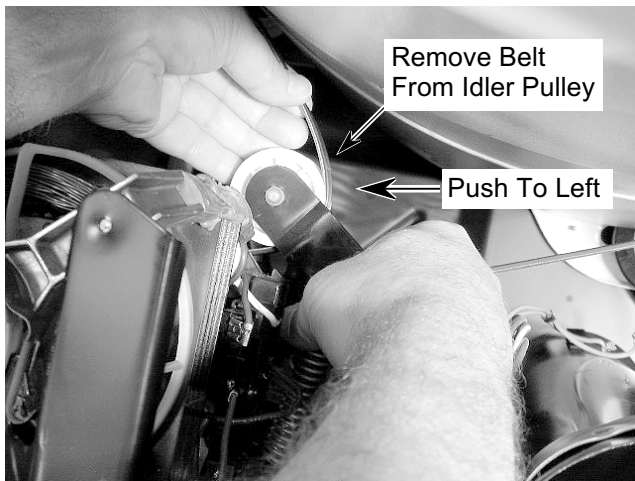

6. Disconnect the 3-wire moisture sensor connector from the main harness connector.

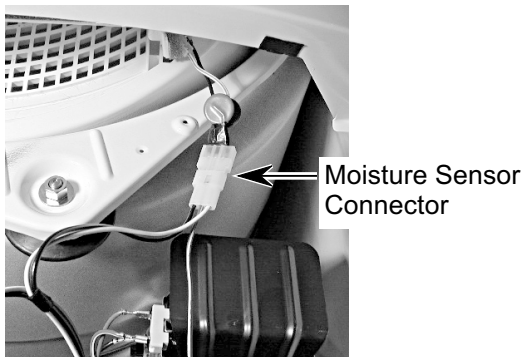

7. Disconnect the 3-wire door switch connector from the machine control electronics board connector.



8. Loosen the two top front panel screws.



9. Remove the two bottom front panel screws.



Continued on the next page.

10. **To remove the belt and drum:**

- a) Grasp the sides, lift, and pull the front panel forward so that the top screws are free of the keyhole slots. Lower the panel so that the drum sits on the components inside the cabinet, and slide the front panel and rollers away from the drum.

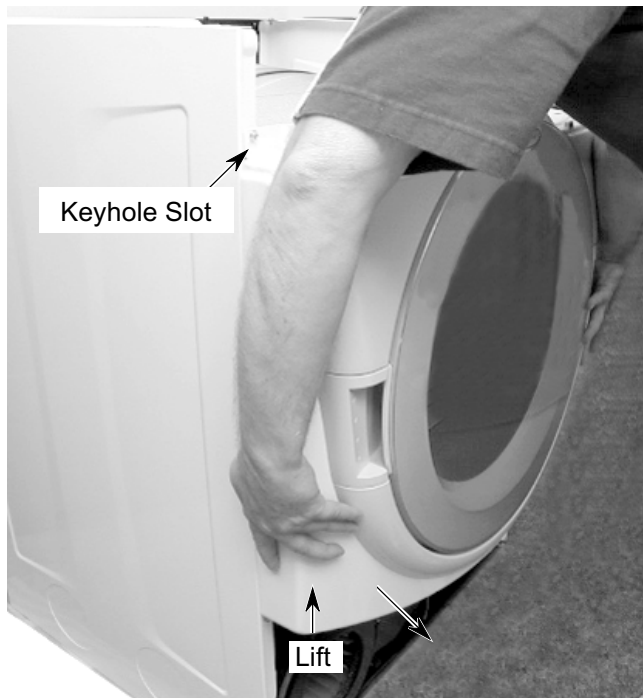

- b) Slide the belt off the drum.

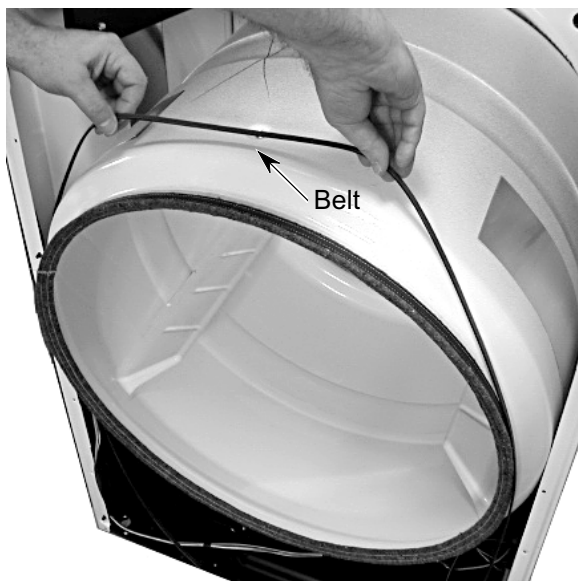

- c) Lift the drum and remove it from the unit.



REASSEMBLY NOTE: Use the following illustration as a guide when installing a new belt.

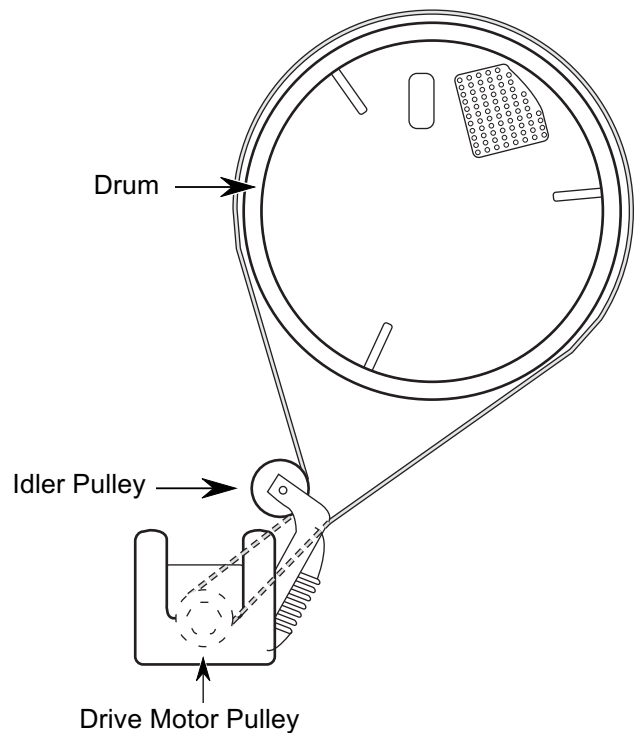

DRUM INSTALLATION NOTE: Be sure to position the drum with the clip toward the front when you reinstall it.

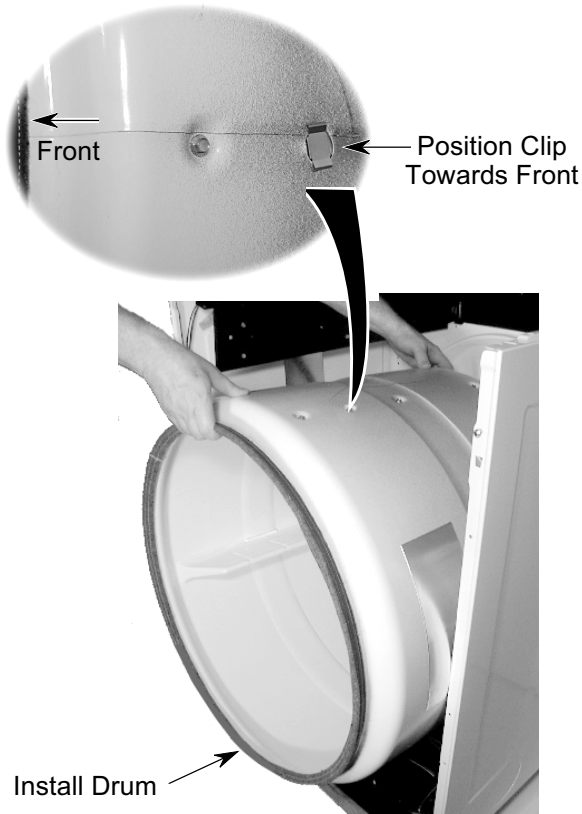

NOTE: There are two rollers on the front panel and two on the rear panel, as shown below.

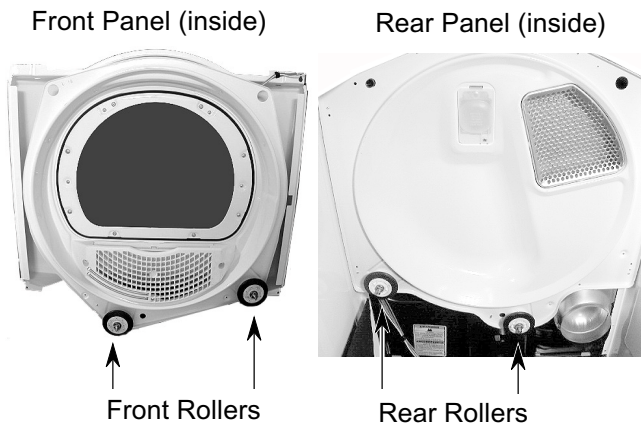

11. To remove a roller:

a) Pry the sides of the triangular ring out of the groove in the roller support with a small screwdriver.

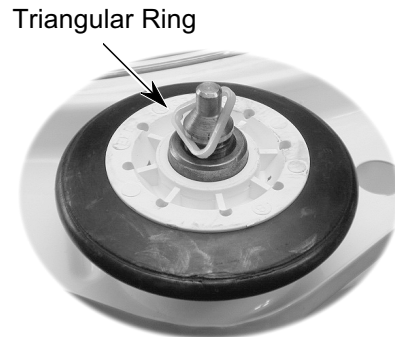

b) Slide the roller off the roller support.

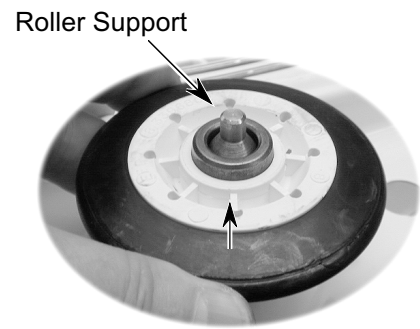

c) Use a 9/16" socket or open-end wrench, and remove the hex nut and flat washer from the roller support, and remove the support. **NOTE:** If you are replacing the roller support, remove the other triangular ring from the support.

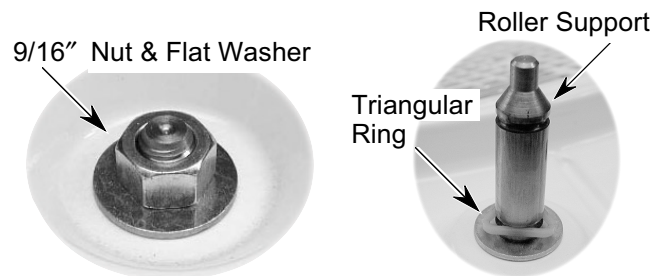

REMOVING THE DRUM LIGHT SOCKET

NOTE: Sharp edges may be present.

1. Turn off the gas to the dryer and disconnect the electrical power.
2. Open the dryer door.
3. Remove the screw from the drum light lens and remove the lens.

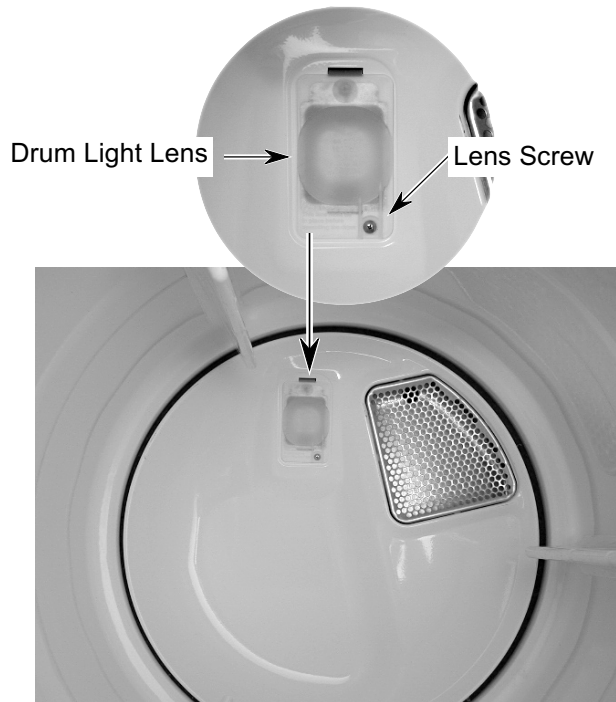

4. Remove the bulb from the drum light socket.
5. Remove the screw from the drum light holder and pull it forward so you can access the wires.

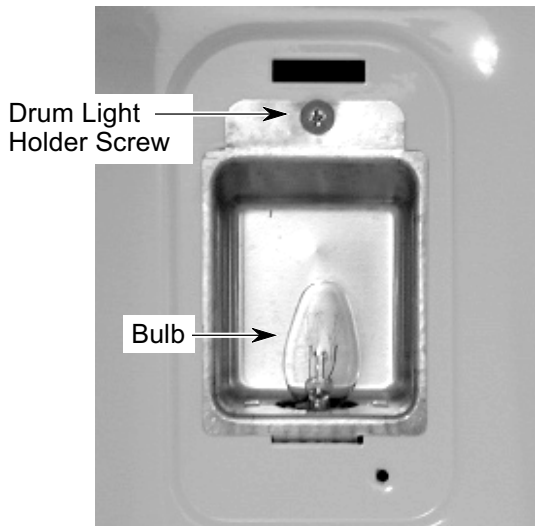

6. Disconnect the wire connectors from the light socket terminals.

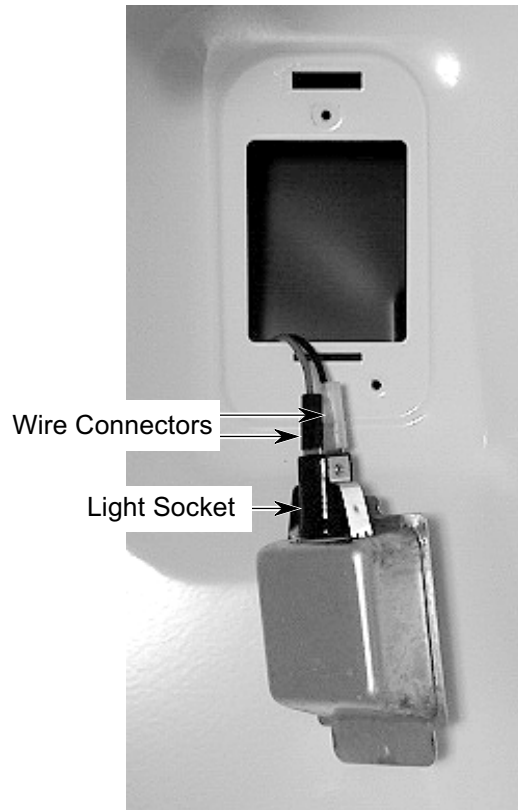

7. Squeeze the locking arms and remove the socket from the drum light holder.

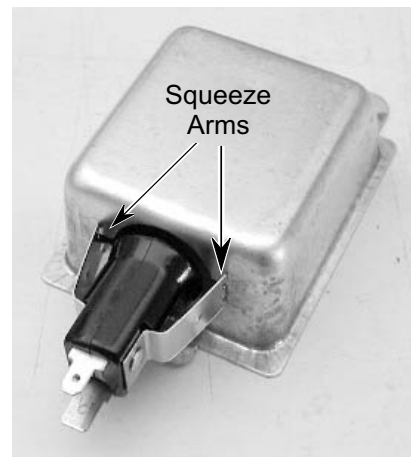

REMOVING THE MOISTURE SENSOR

NOTE: Sharp edges may be present.

1. Turn off the gas to the dryer and disconnect the electrical power.
2. Open the dryer door and remove the lint filter screen.
3. Remove the two front screws from the outlet grille.



4. Remove the three inside screws from the outlet grille.

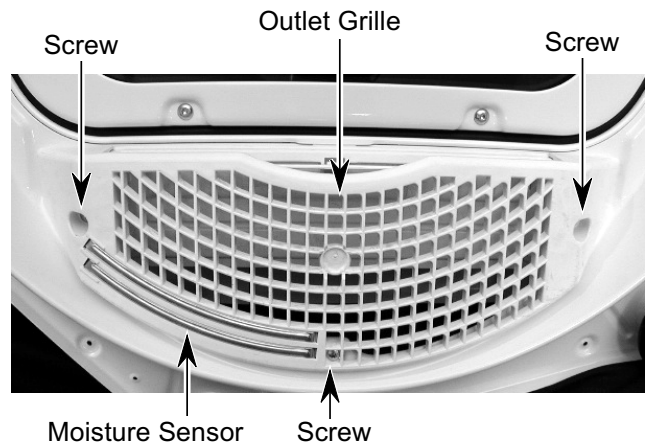

5. Pull the moisture sensor away from the dryer and disconnect the black and yellow-red wires from the moisture sensor strips.

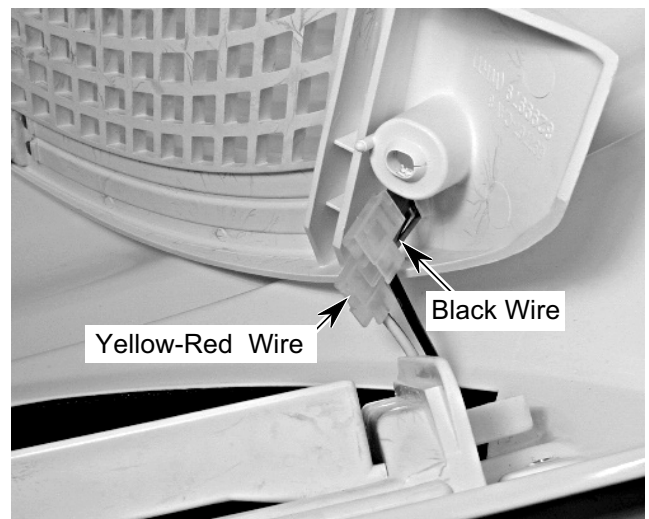

— NOTES —

COMPONENT TESTING

WARNING

ELECTRICAL SHOCK HAZARD

Disconnect power before servicing.

Replace all panels before operating.

Failure to do so could result in death or electrical shock.

Before servicing, check the following:

- Make sure that the power cord is firmly plugged into a live circuit with the proper voltage.
- Check for a blown household fuse or circuit breaker that has tripped.
- Make sure that the dryer vent is properly installed and clear of lint or obstructions.
- Check the connections before replacing a component. Look for broken or loose wires, failed terminals, or wires that are not pressed into their connectors far enough.
- Check for wire connectors that are not pressed tightly onto their terminals.
- Voltage tests must be made with all connectors attached.
- Resistance tests must be made with the power cord unplugged from the outlet, and with the wiring disconnected.
- All tests should be made with a VOM (volt-ohmmeter) or DVM (digital voltmeter) having a sensitivity of 20,000 ohms-per-volt DC or greater.

MAKING ELECTRICAL TESTS

For any additional test beyond what is covered in this Component Testing section, refer to the

Tech Sheet that is supplied with the product.

DRIVE MOTOR

Refer to page 4-7 for the procedure for servicing the drive motor.

1. Disconnect the electrical power to the dryer.
2. Set the ohmmeter to the R X 1 scale.
3. Disconnect the plug from the motor connector.
4. Touch one ohmmeter test lead to the blue motor wire connector, and the other test lead to connector pin 5 (white-orange wire). The ohmmeter should indicate between 2.4 and 3.6 Ω (main winding).

5. Touch one ohmmeter test lead to the blue motor wire connector, and the other test lead to connector pin 3 (violet wire). The ohmmeter should indicate between 2.4 and 3.8 Ω (start winding).
6. If either resistance is much larger than 4 ohms, replace the motor.

If the resistances at the motor are correct, check for a failed belt switch.

If the belt switch is okay, check for an open circuit between the motor and the machine control electronics board.

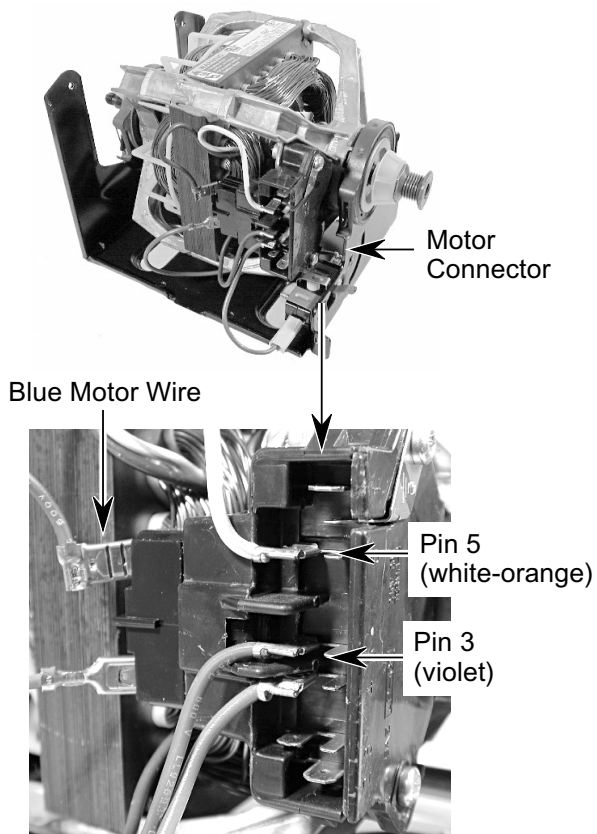

HEATER

Refer to page 4-10 for the procedure for servicing the heater.

1. Disconnect the electrical power to the dryer.
2. Set the ohmmeter to the R X 1 scale.
3. Disconnect one of the wire connectors from the heater terminal block.
4. Touch the ohmmeter test leads to the terminals on the heater terminal block. The ohmmeter should indicate between 7 and 12 ohms.

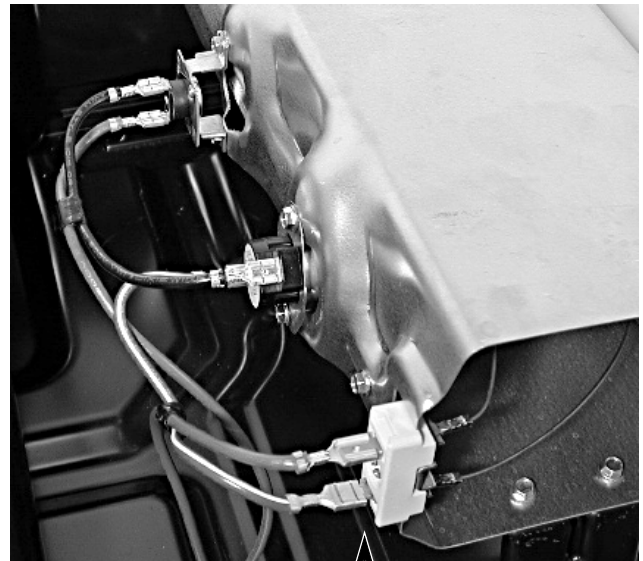

Heater Terminal Block

THERMAL FUSE

Refer to page 4-7 for the procedure for servicing the thermal fuse.

Electric Dryers: The thermal fuse is wired in series with the drive motor. If the thermal fuse opens, 91°C (196°F), power to the motor is turned off. A centrifugal switch on the motor also opens the heater circuit.

Gas Dryers: The thermal fuse is wired in series with the gas valve. If the thermal fuse opens, 91°C (196°F), power to the valve is turned off. A centrifugal switch on the motor also opens the heater circuit.

Once the thermal fuse has opened, it will not reset, and must be replaced. Check for a failed thermistor, or a shorted heater element (electric dryers only).

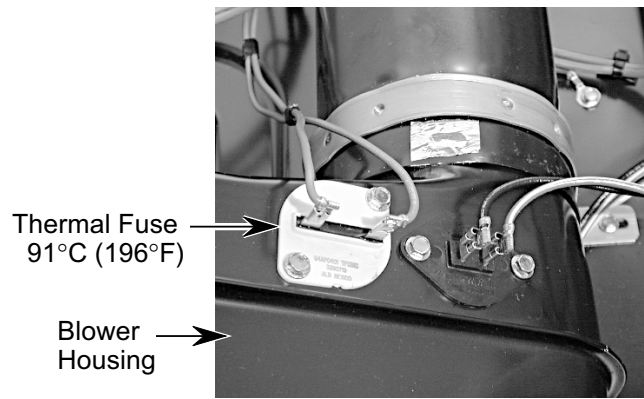

1. Disconnect the electrical power to the dryer.
2. Set the ohmmeter to the R X 1 scale.
3. Disconnect the wires from the thermal fuse.
4. Touch the ohmmeter test leads to the thermal fuse terminals. The ohmmeter should indicate continuity (0 Ω). If the meter indicates an open circuit (infinite), replace the thermal fuse.

THERMISTOR

Refer to page 4-7 for the procedure for servicing the thermistor.

The thermistor monitors the exhaust temperature and cycles the high-limit thermostat on and off to maintain the desired temperature.

1. Turn the dryer off but keep the electrical supply connected.
2. Make sure that the dryer is empty and that the lint screen is clean.
3. Close the dryer door.
4. Select *Heavy Duty, Timed Dry, More Time or Less Time, End of Cycle Signal (Louder) and Start*.
5. If error codes **E1** or **E2** flash on the display after 1 minute and the dryer turns off, the thermistor, or the wire harness, is either shorted or open. Check the wire connections at the thermistor or the machine control electronics board. If wiring checks okay, replace the thermistor.
6. If the dryer seems to operate normally, remove the exhaust vent and start the dryer.
7. Select the desired temperature cycle to be tested, and select 20 minutes of *Timed Dry* heat using the *More Time* or *Less Time* pushbuttons.

8. Hold a glass bulb thermometer capable of reading from 32°C to 82°C (90° to 180°F) in the center of the exhaust outlet. Measure the exhaust temperatures with the heater on and off. The correct exhaust temperatures for the various settings are shown in the following chart.

TEMPERATURE SETTING	HEAT TURNS OFF	HEAT TURNS ON
HIGH	68° C ±6° (155° F ±10°)	
MEDIUM	66° C ±6° (150° F ±10°)	6 - 8° C (10 - 15° F)
HIGH		
MEDIUM	60° C ±6° (140° F ±10°)	below the heat turn off temperature
LOW	52° C ±6° (125° F ±10°)	
EXTRA	41° C ±3°	
LOW	(105° F ±5°)	

9. If the exhaust temperature is not within the specified limits, check the resistance of the thermistor, as shown in the following chart. If the resistance is okay, replace the machine control electronics board.

THERMISTOR RESISTANCE			
TEMP	RESISTANCE	TEMP	RESISTANCE
°C (°F)	(KΩ)	°C (°F)	(KΩ)
10° (50°)	19.9	43° (110°)	4.7
16° (60°)	15.3	49° (120°)	3.7
21° (70°)	11.9	54° (130°)	3.1
27° (80°)	9.2	60° (140°)	2.5
32° (90°)	7.4	66° (150°)	2.1
38° (100°)	5.7	71° (160°)	1.7

THERMAL CUTOFF (ELECTRIC DRYERS ONLY)

Refer to page 4-10 for the procedure for servicing the thermal cutoff.

The thermal cutoff is a non-resettable device. The cutoff temperature is 178°C (352°F).

If the dryer does not heat and there is 240 VAC to the dryer, perform the following test.

1. Disconnect the electrical power to the dryer.
2. Set the ohmmeter to the R X 1 scale.
3. Disconnect the wires from the thermal cutoff.
4. Touch the ohmmeter test leads to the thermal cutoff terminals. The ohmmeter should indicate continuity (0 Ω). If the meter indicates an open circuit (infinite), replace both the thermal cutoff and the high-limit thermostat. In addition, check for a failed heater element, or a blocked, or improper exhaust system.

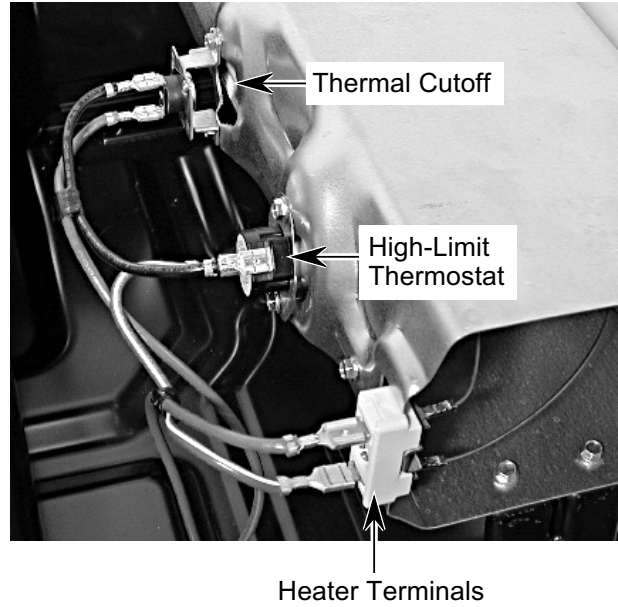

GAS VALVE (GAS DRYERS ONLY)

1. Disconnect the electrical power to the dryer.
2. Set the ohmmeter to the R X 1 scale.
3. Disconnect the wires from the gas valve terminals.
4. Touch the ohmmeter test leads to the terminal numbers shown in the chart. If the resistance readings are not within the limits specified in the chart, replace the gas valve.

IMPORTANT: Make sure to loop the wire harness back through the strain relief after testing.

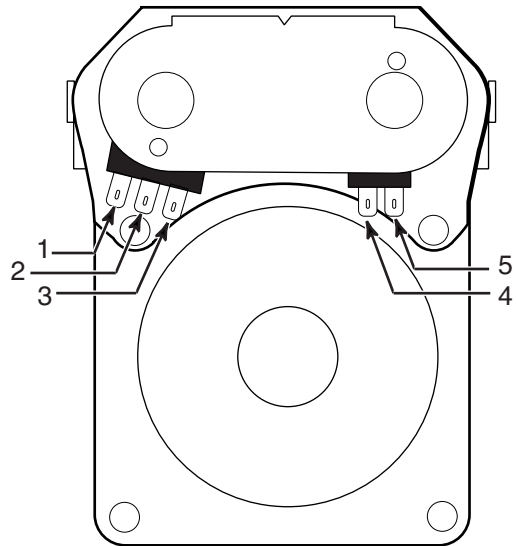

TERMINALS	RESISTANCE
1 to 2	$1365\Omega \pm 25$
1 to 3	$560\Omega \pm 25$
4 to 5	$1220\Omega \pm 50$

MOISTURE SENSOR

Refer to page 4-15 for the procedure for servicing the moisture sensor.

Perform this test if the dryer shuts off too soon when set to an automatic cycle.

1. Set the dryer to the "Diagnostic Test Mode" (refer to the procedure on page 6-1).
2. Open the dryer door.
3. Place a finger across the two metal sensor strips on the lint screen housing. If a beep tone sounds and "03" is displayed in the console window, the sensor is working normally.

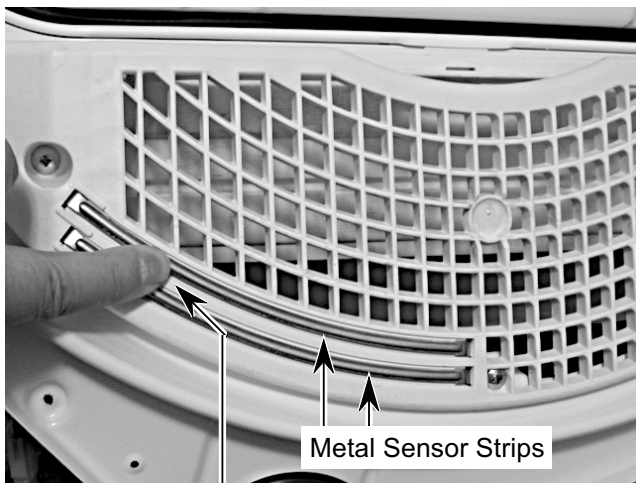

Bridge Strips
With Finger

4. If the moisture sensor fails the diagnostic test, check the moisture sensor wiring. Disconnect the power to the dryer, use an ohmmeter, and check the yellow-red and black wires for shorts (continuity to ground), first with no load (wire connector disconnected), and then with a load (connected).
5. If the diagnostic test passes, perform the thermistor test (refer to page 5-5).
6. If the problem still exists after replacing the thermistor, check the ribbon connections from the control panel to the machine control electronics board.
7. If all of the above are satisfactory, replace the machine control electronics board.

CONSOLE PUSHBUTTONS & LEDS

Refer to page 4-4 for the procedure for servicing the console.

Refer to the Diagnostic Tests on page 6-1, and activate the "Diagnostic Test Mode." Check for the following situations:

- None of the LEDs light.
- A particular group of LEDs does not light.
- One LED does not light.
- No beep sounds.
- No dryer function is activated when a particular pushbutton is pressed.
- An "E3" error code is displayed.



Console Pushbuttons & LEDs

Refer to the following test that corresponds to your problem.

NONE OF THE LEDS LIGHT

1. Check to make sure that ribbon connectors P3 and P4 are inserted all the way into the machine control electronics board.

Machine Control Electronics Board

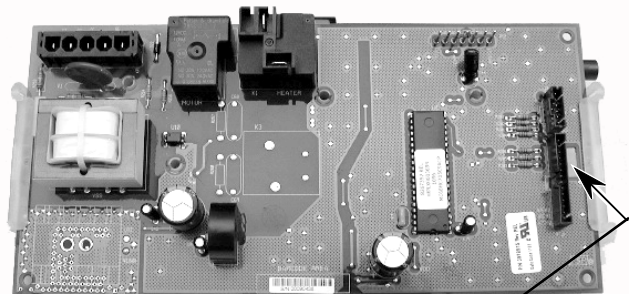

Viewed From This Side

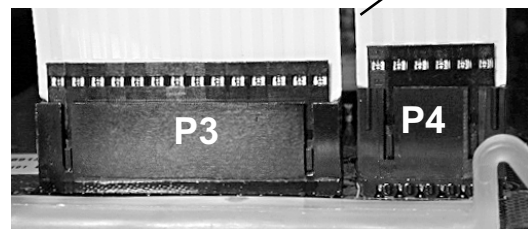

A PARTICULAR GROUP OF LEDS DOES NOT LIGHT

A group or combination of LEDs share a common electronic connection. If this connection is open, all of the LEDs in the group will be disabled. If this occurs, replace the entire console electronics and housing.

ONE LED DOES NOT LIGHT

Press the button associated with the LED several times. If the LED does not light, the LED has failed. Replace the entire console electronics and housing.

NO BEEP SOUNDS

If the associated LEDs do light up, the beeper circuit may have failed on the machine control electronics board.

NO DRYER FUNCTION IS ACTIVATED WHEN A PARTICULAR PUSHBUTTON IS PRESSED

If the associated LEDs do light up, the machine control electronics board may have failed.

AN E3 ERROR CODE IS DISPLAYED

An **E3** error code means that there is a user interface or a software mismatch. It can also mean that a component on the console electronics, or the machine control electronics board has failed.

DOOR SWITCH

Refer to page 4-6 for the procedure for servicing the door switch.

1. Set the dryer to the "Diagnostic Test Mode" (refer to the procedure on page 6-1).
2. Open and close the dryer door. You should hear a "beep" each time the door is closed and opened, and "OE" should be displayed in the console window whenever the door is opened.

If a beep does not sound, or if "OE" is displayed with the door closed, check the wiring between the door switch and the machine control electronics board for positive connections or short circuits (see the photo).

If the wiring is okay, perform the resistance tests.



RESISTANCE TESTS

1. Disconnect the electrical power to the dryer.
2. Close the dryer door.
3. Disconnect the 3-wire connector from the door switch to the machine control electronics board.
4. Set the ohmmeter to the R X 1 scale.

Refer to the illustration below for the following tests.

5. Touch the black ohmmeter test lead to the white wire pin in the connector and leave it there for the remaining tests.
6. Touch the red ohmmeter test lead to the brown wire pin in the connector. The meter should indicate an open circuit (infinite).
7. Touch the red ohmmeter test lead to the blue wire pin in the connector. The meter should indicate a closed circuit (0 ohms).
8. Open the dryer door.
9. Touch the red ohmmeter test lead to the blue wire pin in the connector. The meter should indicate an open circuit (infinite).
10. Touch the red ohmmeter test lead to the brown wire pin in the connector. The meter should indicate a closed circuit (0 ohms).
11. If the resistance test is incorrect, replace the wire and door switch assembly, (see page 4-6 for the procedure), and retest.

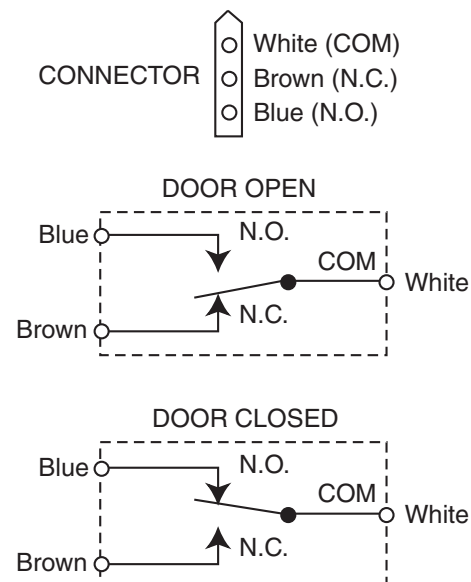

DIAGNOSIS AND TROUBLESHOOTING

DIAGNOSIS

DISPLAY FAULT/ERROR CODES

DISPLAY	DESCRIPTION	EXPLANATION & RECOMMENDED
		PROCEDURE
<i>PF</i>	Power Failure	"PF" Flashes to indicate that a power failure occurred while the dryer was running.
		Press START to continue the cycle, or press STOP/CANCEL to clear the display.
<i>E1</i>	Thermistor Open	"E1" flashes if the thermistor is open.
		See "Thermistor Test" on page 5-5.
<i>E2</i>	Thermistor Shorted	"E2" flashes if the thermistor has shorted.
		See "Thermistor Test" on page 5-5.

DIAGNOSTIC TESTS

The Diagnostic Tests will test and verify all of the inputs to the machine control electronics board. These tests are an overall check of the dryer electronics and the related components. The tests should be run prior to making any of the troubleshooting tests.

ACTIVATING THE DIAGNOSTIC TEST MODE

1. Make sure that the dryer is in the "Standby" mode (plugged in and all of the indicators are off).
2. Press the following control panel keypad sequence all within 5 seconds:
More Time—Less Time—More Time—Less Time.
3. All indicators on the console should now be illuminated with "88" showing in the "Estimated Time Remaining" display, if this test mode has been entered successfully.

NOTE: If the "Diagnostic Test Mode" entry was unsuccessful, perform the following actions for specific indications.

Indication #1

Problem: None of the indicators or display digits light.

Corrective Action: Press one of the *Manual Cycles* pushbuttons. If the indicators light, change the dryer time by pressing the *More Time* and *Less Time* pushbuttons.

If either pushbutton fails to change the time, the pushbutton is defective, and it is not possible to enter the diagnostic mode.

Remove the console electronics and housing (see page 4-4).

Indication #2

Problem: *E1* or *E2* flashes on the display.

Corrective Action: Refer to "Thermistor Test" on page 5-5.

Indication #3

Problem: *E3* flashes on the display.

Corrective Action: Check that the correct console electronics and housing, and the machine control electronics board are installed. To do this, remove these components (see pages 4-2 through 4-5 for the procedures). Check the part numbers and compare them to the part numbers shown in the Tech Sheet that is supplied with the dryer. Replace the components, if necessary.

KEYPAD TEST

1. Press the *Dryness Level* keypad.
The three *Dryness Level* LEDs should turn off and the dryer should beep.
2. Press the *Control On* keypad.
The *Control Locked* LED should turn off.
3. Turn the cycle selector knob one complete rotation.
When the knob points to a cycle, the corresponding LED should go out, and the dryer should beep. When the knob is pointing in the large spaces between the *Manual* and *Automatic* cycle groups, only a beep should be heard.
4. Touch the *More Time* keypad.
The most significant “8” should turn off and the dryer should beep.
5. Touch the *Less Time* keypad.
The least significant “8” should turn off and the dryer should beep.
6. Touch the *Wrinkle Shield* keypad.
The corresponding LED should turn off and the dryer should beep.

7. Touch the *Temperature* keypad.
The five *Temperature Level* LEDs should turn off and the dryer should beep.
8. Touch the *End Of Cycle Signal* keypad.
The three *End Of Cycle* level LEDs should turn off and the dryer should beep.

ADDITIONAL TESTS

1. Open the dryer door.
The dryer should beep and the display will show a number, followed by a capital “E” for electric models, or a lower case “g” for gas models. The first number will be a 3 (Whirlpool access).
2. Touch the *Sensing* keypad.
The dryer should beep while touching the keypad and the display will show a 2-digit software revision code.
3. Close the dryer door.
The display should turn blank.
4. Touch the *Start* keypad.
The *Status* LEDs should turn off, the heater and motor should turn on, and the display should read a 2-digit project ID code.

TROUBLESHOOTING GUIDE

PROBLEM	POSSIBLE CAUSE/TEST
Unit will not power up.	<ol style="list-style-type: none"> 1. Check the 120 VAC electrical supply. 2. Check the wiring harness connections. 3. Check the control electronics.
Unit will not cycle when <i>Start</i> pushbutton is pressed.	<ol style="list-style-type: none"> 1. Be sure to hold the <i>Start</i> pushbutton down for 3 seconds. 2. Check the wiring harness connections. 3. If the displayed number flashes, make sure the door is completely closed. Press and hold the <i>Start</i> pushbutton down for 3 seconds.
Unit will not turn off.	<ol style="list-style-type: none"> 1. Test the <i>Pause/Cancel</i> pushbutton. 2. Check the control electronics and housing. 3. Check the moisture sensor.
The control panel will not accept commands.	<ol style="list-style-type: none"> 1. Check the control electronics and housing.
The unit will not heat.	<ol style="list-style-type: none"> 1. Check the heater voltage. 2. Check the wire connections to the heater.
The unit heats during the “air” cycle.	<ol style="list-style-type: none"> 1. Check the thermistor.
The unit turns off before the clothes are dry.	<ol style="list-style-type: none"> 1. Check the moisture sensor.

— NOTES —

WIRING DIAGRAMS

ELECTRIC DRYER

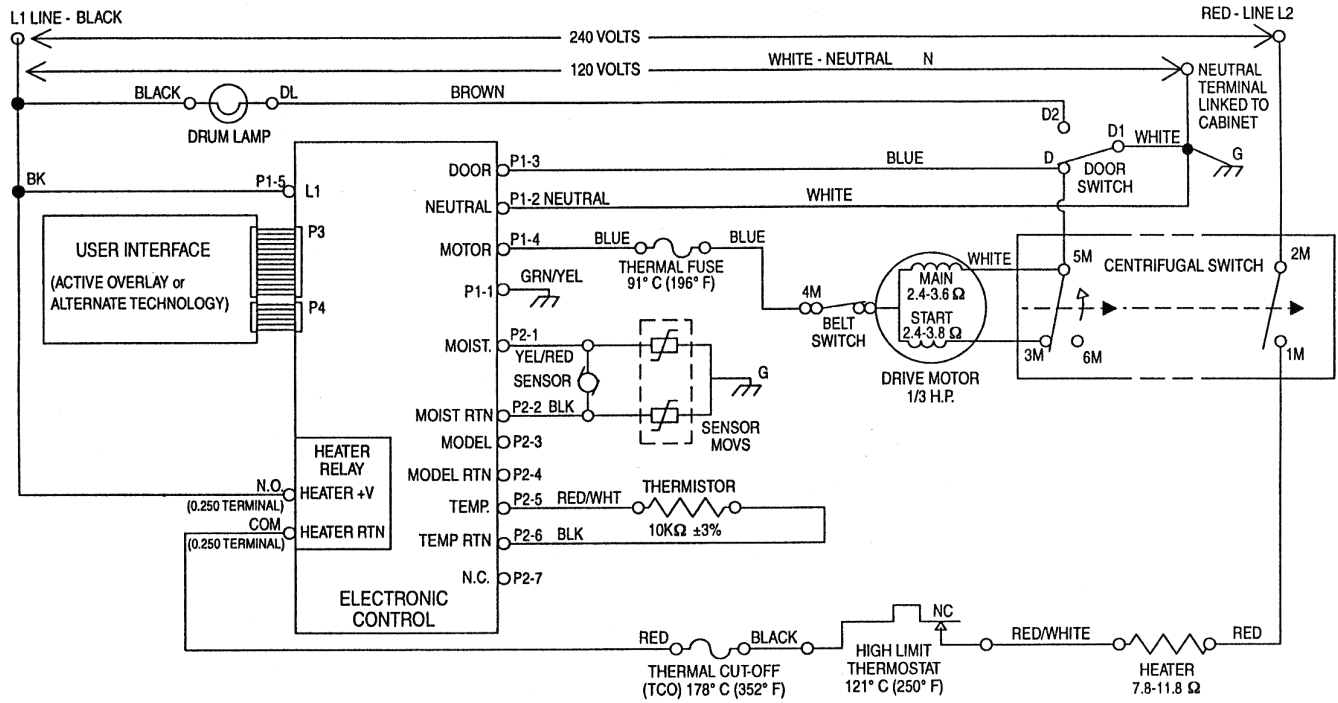

GAS DRYER

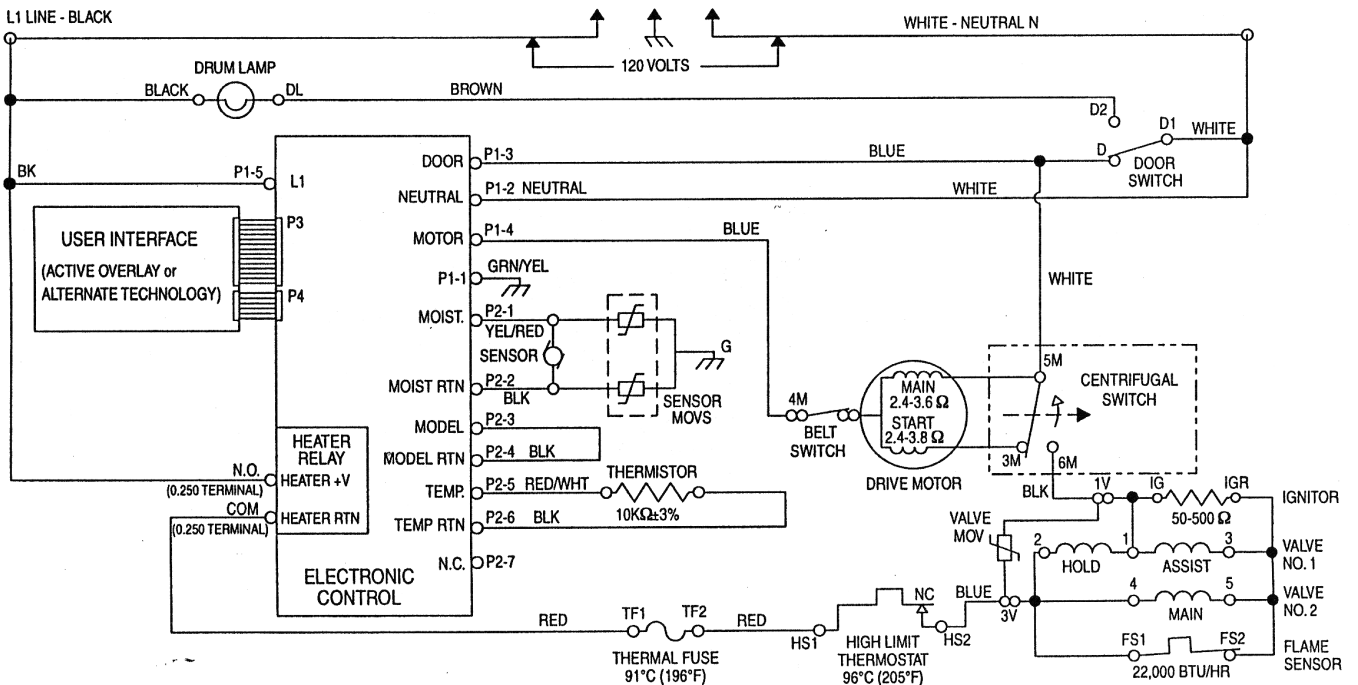

— NOTES —

— NOTES —

— NOTES —

PRODUCT SPECIFICATIONS AND WARRANTY INFORMATION SOURCES

IN THE UNITED STATES:

FOR PRODUCT SPECIFICATIONS AND WARRANTY INFORMATION CALL:

FOR WHIRLPOOL PRODUCTS: 1-800-253-1301

FOR KITCHENAID PRODUCTS: 1-800-422-1230

FOR ROPER PRODUCTS: 1-800-447-6737

FOR TECHNICAL ASSISTANCE WHILE AT THE CUSTOMER'S HOME CALL:

THE TECHNICAL ASSISTANCE LINE: 1-800-253-2870

**HAVE YOUR STORE NUMBER READY TO IDENTIFY YOU AS AN
AUTHORIZED SERVICER**

FOR LITERATURE ORDERS:

PHONE: 1-800-851-4605

IN CANADA:

FOR PRODUCT SPECIFICATIONS AND WARRANTY INFORMATION CALL:

1-800-461-5681

FOR TECHNICAL ASSISTANCE WHILE AT THE CUSTOMER'S HOME CALL:

THE TECHNICAL ASSISTANCE LINE: 1-800-488-4791

**HAVE YOUR STORE NUMBER READY TO IDENTIFY YOU AS AN
AUTHORIZED SERVICER**

